



Saber 3°, 5° y 9° 2013
Cuadernillo de prueba
Segunda edición

Matemáticas
Grado 9°

Presidente de la República
Juan Manuel Santos Calderón

Ministra de Educación Nacional
Gina María Parody d'Echeona

Viceministro de Educación Preescolar, Básica y Media
Víctor Javier Saavedra Mercado

Directora General
Ximena Dueñas Herrera

Secretaria General
María Sofía Arango Arango

Director de Evaluación
Hugo Andrés Gutierrez Rojas

Directora de Producción y Operaciones
Francia María del Pilar Jiménez Franco

Directora de Tecnología
Ingrid Picón Carrascal

Oficina Asesora de Comunicaciones y Mercadeo

Oficina Gestión de Proyectos de Investigación

Subdirector de Producción de Instrumentos
Luis Javier Toro Baquero

Subdirectora de Análisis y Divulgación
Silvana Godoy Mateus

Adaptación y elaboración del documento
Diana Oquendo Victoria
Martha Jeanet Castillo Ballén

Diseño y diagramación
Cecilia Martínez Rodríguez
Nathalia Chavarro Morcote
Alejandra Guzmán Escobar
Gustavo Andrés Álvarez Mejía

ISBN de la versión digital: En trámite

Bogotá D.C., junio de 2016



ADVERTENCIA

Con el fin de evitar la sobrecarga gráfica que supondría utilizar en español “o/a” para denotar uno u otro género, el Icfes opta por emplear el masculino genérico en el que todas las menciones de este se refieren siempre a hombres y mujeres.

Todo el contenido es propiedad exclusiva y reservada del Icfes y es el resultado de investigaciones y obras protegidas por la legislación nacional e internacional. No se autoriza su reproducción, utilización ni explotación a ningún tercero. Solo se autoriza su uso para fines exclusivamente académicos. Esta información no podrá ser alterada, modificada o enmendada.

TÉRMINOS Y CONDICIONES DE USO PARA PUBLICACIONES Y OBRAS DE PROPIEDAD DEL ICFES

El Instituto Colombiano para la Evaluación de la Educación (Icfes) pone a la disposición de la comunidad educativa y del público en general, **DE FORMA GRATUITA Y LIBRE DE CUALQUIER CARGO**, un conjunto de publicaciones a través de su portal www.icfes.gov.co. Dichos materiales y documentos están normados por la presente política y están protegidos por derechos de propiedad intelectual y derechos de autor a favor del Icfes. Si tiene conocimiento de alguna utilización contraria a lo establecido en estas condiciones de uso, por favor infórmenos al correo prensaicfes@icfes.gov.co.

Queda prohibido el uso o publicación total o parcial de este material con fines de lucro. **Únicamente está autorizado su uso para fines académicos e investigativos.** Ninguna persona, natural o jurídica, nacional o internacional, podrá vender, distribuir, alquilar, reproducir, transformar*, promocionar o realizar acción alguna de la cual se lucre directa o indirectamente con este material. Esta publicación cuenta con el registro ISBN (International Standard Book Number, o Número Normalizado Internacional para Libros) que facilita la identificación no solo de cada título, sino de la autoría, la edición, el editor y el país en donde se edita.

En todo caso, cuando se haga uso parcial o total de los contenidos de esta publicación del Icfes, el usuario deberá consignar o hacer referencia a los créditos institucionales del Icfes respetando los derechos de cita; es decir, se podrán utilizar con los fines aquí previstos transcribiendo los pasajes necesarios, citando siempre al Icfes como fuente de autor. Lo anterior siempre que los pasajes no sean tantos y seguidos que razonadamente puedan considerarse como una reproducción simulada y sustancial, que redunde en perjuicio del Icfes.

Asimismo, los logotipos institucionales son marcas registradas y de propiedad exclusiva del Icfes. Por tanto, los terceros no podrán usar las marcas de propiedad del Icfes con signos idénticos o similares respecto de cualesquiera productos o servicios prestados por esta entidad, cuando su uso pueda causar confusión. En todo caso queda prohibido su uso sin previa autorización expresa del Icfes. La infracción de estos derechos se perseguirá civil y, en su caso, penalmente, de acuerdo con las leyes nacionales y tratados internacionales aplicables.

El Icfes realizará cambios o revisiones periódicas a los presentes términos de uso, y los actualizará en esta publicación.

El Icfes adelantará las acciones legales pertinentes por cualquier violación a estas políticas y condiciones de uso.

* La transformación es la modificación de la obra a través de la creación de adaptaciones, traducciones, compilaciones, actualizaciones, revisiones y, en general, cualquier modificación que de la obra se pueda realizar, de modo que la nueva obra resultante se constituya en una obra derivada protegida por el derecho de autor, con la única diferencia respecto de las obras originales de que aquellas requieren para su realización de la autorización expresa del autor o propietario para adaptar, traducir, compilar, etcétera. En este caso, el Icfes prohíbe la transformación de esta publicación.



GRADO 9°



GRADO 9° - PRUEBA DE MATEMÁTICAS

• Pregunta 1.

Un escalador quiere subir un muro. En el primer intento subió 6,5 metros y resbaló 2. En el segundo intento alcanzó la parte más alta del muro subiendo 7,3 metros desde el punto donde quedó en el primer intento.

¿Cuál o cuáles de los siguientes procedimientos permiten determinar correctamente la altura h del muro?

I.	$h = (6,5 + 7,3) + (-2)$
II.	$h = (6,5 - 2) + 7,3$
III.	$h = 6,5 - (2 + 7,3)$

- A. I solamente.
- B. III solamente.
- C. I y II solamente.
- D. II y III solamente.

• Estructura

Competencia	Razonamiento
Componente	Numérico - variacional
Afirmación	Reconocer el uso de propiedades y relaciones de los números reales.
Nivel de desempeño	Satisfactorio
Respuesta Correcta	C

• Resultados a nivel nacional y de Entidad Territorial Certificada (ETC)

ETC/País	A	B	C	D	Omisión y multimarca	N° estudiantes
Amazonas	26.5%	20.7%	29.5%	21.9%	1.4%	589
Antioquia	21.8%	14.2%	42.2%	19.4%	2.4%	16846
Apartadó	26.6%	15.8%	35.7%	21.1%	0.8%	1019
Arauca	21.6%	11.8%	46.9%	19.0%	0.7%	1614
Armenia	20.7%	13.7%	47.4%	17.9%	0.3%	2415
Atlántico	25.3%	16.3%	35.8%	21.3%	1.2%	4578
Barrancabermeja	22.0%	12.9%	47.0%	17.6%	0.6%	1899
Barranquilla	21.3%	13.3%	45.6%	18.7%	1.1%	9988
Bello	21.9%	12.0%	47.5%	17.8%	0.8%	3092
Bogotá, D.C.	17.6%	10.6%	54.6%	16.4%	0.8%	60321
Bolívar	23.6%	16.5%	35.1%	23.7%	1.2%	7070
Boyacá	18.6%	12.8%	48.5%	19.3%	0.8%	7298
Bucaramanga	16.3%	9.3%	57.5%	15.8%	1.0%	4681
Buenaventura	22.3%	16.6%	37.6%	22.4%	1.1%	2198
Buga	23.6%	12.9%	45.0%	17.0%	1.5%	884
Caldas	22.4%	14.5%	42.6%	19.8%	0.7%	4244
Cali	19.9%	12.4%	47.8%	18.5%	1.3%	16005
Caquetá	23.8%	16.5%	39.1%	18.9%	1.8%	1587
Cartagena	23.3%	13.8%	41.0%	20.2%	1.6%	8877
Cartago	17.5%	16.0%	47.6%	17.7%	1.3%	865
Casanare	18.3%	14.0%	47.9%	18.8%	1.0%	2075
Cauca	21.6%	15.9%	39.3%	21.5%	1.7%	7914
Cesar	23.3%	16.3%	35.8%	23.6%	1.0%	5112
Chocó	26.0%	18.9%	31.0%	23.2%	0.9%	1896
Chía	15.7%	8.5%	56.9%	18.5%	0.5%	1289
Ciénaga	26.4%	18.4%	32.4%	21.7%	1.2%	997
Cundinamarca	19.2%	11.5%	48.8%	19.1%	1.4%	13471
Córdoba	24.3%	18.1%	35.0%	21.8%	0.9%	8801
Cúcuta	20.5%	11.8%	51.2%	16.0%	0.4%	6040
Dosquebradas	17.6%	14.0%	51.5%	16.0%	0.9%	1265
Duitama	14.9%	8.5%	63.1%	12.9%	0.6%	1067
Envigado	19.7%	9.3%	56.2%	14.1%	0.7%	1677
Facatativá	18.3%	10.8%	51.4%	18.6%	0.8%	1064
Florencia	19.2%	13.5%	47.5%	19.6%	0.2%	1285
Floridablanca	15.5%	10.0%	59.6%	14.6%	0.3%	2014
Fusagasugá	16.9%	11.7%	51.6%	19.4%	0.4%	1228
Girardot	26.2%	15.9%	37.6%	20.2%	0.1%	901

Continúa en la siguiente página



ETC/País	A	B	C	D	Omisión y multimarca	N° estudiantes
Girón	17.7%	9.9%	53.9%	17.7%	0.8%	945
Guainía	20.7%	20.1%	36.6%	22.6%	0.0%	164
Guaviare	23.5%	14.1%	43.5%	17.2%	1.7%	575
Huila	19.8%	13.6%	46.1%	19.6%	0.9%	5160
Ibagué	19.2%	12.4%	50.2%	17.5%	0.8%	4329
Ipiales	15.4%	8.7%	56.1%	19.0%	0.8%	1011
Itagüí	28.4%	14.0%	40.7%	15.6%	1.3%	1498
Jamundí	21.5%	12.2%	44.0%	22.0%	0.3%	885
La Guajira	25.1%	16.1%	35.9%	21.9%	1.0%	1790
Lorica	25.4%	20.1%	30.4%	23.7%	0.4%	1167
Magangué	23.4%	16.6%	34.4%	20.8%	4.8%	903
Magdalena	26.4%	19.1%	31.7%	21.4%	1.4%	5178
Maicao	27.0%	17.9%	34.0%	20.7%	0.4%	1132
Malambo	22.0%	16.2%	38.5%	22.3%	1.0%	837
Manizales	21.5%	11.8%	49.5%	16.5%	0.7%	2878
Medellín	21.6%	12.7%	46.6%	17.8%	1.3%	16966
Meta	20.9%	15.1%	44.7%	18.6%	0.7%	3388
Montería	22.3%	13.8%	42.7%	20.4%	0.7%	3981
Mosquera	19.3%	10.4%	53.1%	17.1%	0.1%	1037
Nariño	18.1%	11.2%	48.3%	21.5%	1.0%	5979
Neiva	18.1%	12.1%	52.0%	17.3%	0.6%	3004
Norte de Santander	21.5%	12.5%	47.3%	18.1%	0.6%	4838
Palmira	18.3%	11.6%	50.4%	19.0%	0.7%	2248
Pasto	16.4%	10.1%	53.4%	19.2%	0.9%	3679
Pereira	19.7%	12.1%	50.5%	17.1%	0.5%	3671
Piedecuesta	17.3%	11.0%	56.2%	15.2%	0.3%	1187
Pitalito	20.4%	12.2%	49.4%	17.4%	0.5%	1112
Popayán	18.6%	10.7%	52.5%	17.6%	0.6%	2345
Putumayo	18.5%	14.2%	46.2%	19.8%	1.3%	2502
Quibdó	23.2%	18.4%	35.0%	21.7%	1.7%	1233
Quindío	22.0%	13.3%	45.2%	19.2%	0.3%	2071
Riohacha	23.2%	17.6%	40.1%	18.9%	0.2%	1323
Rionegro	18.2%	10.3%	54.6%	16.3%	0.6%	1074
Risaralda	22.9%	13.4%	44.3%	18.9%	0.5%	1908
Sabaneta	17.3%	7.4%	56.2%	12.8%	6.3%	525
Sahagún	22.1%	13.9%	38.2%	25.8%	0.0%	1089
San Andrés	25.4%	16.7%	36.3%	19.2%	2.4%	449
Santa Marta	24.7%	16.7%	38.2%	19.4%	1.0%	4139
Santander	18.3%	12.1%	49.7%	19.5%	0.4%	6241

Continúa en la siguiente página

ETC/País	A	B	C	D	Omisión y multimarca	N° estudiantes
Sincelejo	21.9%	14.9%	43.4%	19.3%	0.5%	2462
Soacha	21.6%	12.5%	47.2%	18.0%	0.7%	4523
Sogamoso	15.6%	10.1%	54.3%	18.0%	2.0%	1361
Soledad	22.0%	14.1%	43.2%	20.0%	0.8%	3637
Sucre	23.5%	16.4%	36.5%	22.9%	0.7%	5370
Tolima	22.5%	15.7%	40.1%	20.4%	1.3%	6918
Tuluá	20.1%	14.1%	46.3%	19.4%	0.1%	1849
Tumaco	22.3%	18.5%	33.7%	24.6%	0.8%	1327
Tunja	14.9%	10.4%	56.9%	16.5%	1.3%	1487
Turbo	27.0%	18.8%	29.8%	22.3%	2.0%	999
Uribe	27.7%	23.6%	29.5%	18.2%	1.0%	292
Valle del Cauca	21.6%	14.8%	41.2%	20.6%	1.8%	6865
Valledupar	22.5%	14.4%	39.0%	18.9%	5.2%	3940
Vaupés	19.1%	21.7%	34.9%	21.1%	3.3%	152
Vichada	26.0%	16.0%	34.6%	22.7%	0.7%	269
Villavicencio	20.2%	12.1%	51.3%	15.8%	0.6%	3946
Yopal	17.6%	9.8%	53.0%	19.0%	0.5%	1271
Zipaquirá	19.9%	8.9%	53.3%	17.7%	0.2%	1108
Colombia	20.6%	13.2%	46.3%	18.9%	1.1%	366383

*Es posible que los porcentajes mostrados no sumen exactamente 100 debido a aproximaciones decimales.



- **Pregunta 2.**

Para cercar un jardín se compraron dos tipos de malla, *A* y *B*.

Del tipo *A*, dos rollos de 25,5 metros cada uno, y del tipo *B*, dos rollos cada uno con 7 metros de malla menos que un rollo del tipo *A*.

¿Cuál de los siguientes procedimientos permite determinar correctamente la cantidad de metros comprados para cercar el jardín?

- A. $(2 \times 25,5) + 2 \times (25,5 + 7)$
- B. $2 \times [25,5 - 7]$
- C. $2 \times [2 \times (25,5) - (2 \times 7)]$
- D. $(2 \times 25,5) + 2 \times (25,5 - 7)$

- **Estructura**

Competencia	Razonamiento
Componente	Numérico - variacional
Afirmación	Reconocer el uso de propiedades y relaciones de los números reales.
Nivel de desempeño	Avanzado
Respuesta correcta	D

• Resultados a nivel nacional y de Entidad Territorial Certificada (ETC)

ETC/País	A	B	C	D	Omisión y multimarca	N° estudiantes
Amazonas	24.1%	29.7%	23.4%	21.2%	1.5%	589
Antioquia	20.6%	25.8%	21.1%	29.9%	2.7%	16846
Apartadó	19.2%	30.0%	22.0%	28.1%	0.7%	1019
Arauca	17.8%	25.4%	21.6%	34.0%	1.2%	1614
Armenia	18.8%	25.1%	20.7%	34.7%	0.7%	2415
Atlántico	22.8%	28.4%	22.0%	25.3%	1.6%	4578
Barrancabermeja	20.9%	25.8%	19.7%	32.4%	1.2%	1899
Barranquilla	19.5%	26.1%	17.4%	35.6%	1.4%	9988
Bello	20.4%	24.4%	20.4%	33.7%	1.2%	3092
Bogotá, D.C.	17.7%	21.9%	17.9%	41.3%	1.2%	60321
Bolívar	23.6%	28.9%	21.7%	24.3%	1.5%	7070
Boyacá	19.1%	25.1%	20.2%	34.6%	1.0%	7298
Bucaramanga	15.4%	20.9%	16.2%	46.0%	1.5%	4681
Buenaventura	22.4%	26.8%	20.5%	28.8%	1.4%	2198
Buga	16.5%	27.9%	16.3%	37.4%	1.8%	884
Caldas	20.0%	26.4%	21.9%	30.8%	0.9%	4244
Cali	19.4%	24.4%	19.1%	35.3%	1.9%	16005
Caquetá	20.0%	28.2%	22.4%	27.1%	2.4%	1587
Cartagena	21.5%	25.5%	19.3%	31.7%	2.0%	8877
Cartago	20.3%	23.0%	20.2%	34.7%	1.7%	865
Casanare	20.3%	24.9%	21.3%	32.4%	1.0%	2075
Cauca	22.7%	27.4%	20.6%	27.3%	2.1%	7914
Cesar	22.4%	27.2%	22.0%	27.1%	1.2%	5112
Chocó	23.8%	33.3%	20.7%	20.5%	1.7%	1896
Chía	16.5%	20.5%	16.8%	45.6%	0.6%	1289
Ciénaga	24.6%	27.3%	22.6%	24.0%	1.6%	997
Cundinamarca	17.9%	23.5%	20.0%	36.9%	1.6%	13471
Córdoba	24.0%	28.2%	22.1%	24.4%	1.3%	8801
Cúcuta	19.9%	22.2%	20.3%	37.0%	0.7%	6040
Dosquebradas	16.2%	25.9%	19.6%	37.1%	1.2%	1265
Duitama	13.5%	18.8%	16.5%	50.5%	0.7%	1067
Envigado	15.1%	18.7%	17.4%	48.1%	0.8%	1677
Facatativá	20.9%	23.4%	15.4%	39.4%	0.9%	1064
Florencia	21.2%	25.7%	18.1%	34.6%	0.5%	1285
Floridablanca	16.2%	18.4%	17.5%	47.3%	0.5%	2014
Fusagasugá	18.2%	21.2%	18.3%	41.4%	0.9%	1228
Girardot	20.5%	27.4%	21.5%	30.0%	0.6%	901

Continúa en la siguiente página



ETC/País	A	B	C	D	Omisión y multimarca	N° estudiantes
Girón	17.6%	22.0%	18.2%	40.3%	1.9%	945
Guainía	18.9%	29.9%	23.8%	26.2%	1.2%	164
Guaviare	21.7%	30.3%	21.6%	24.7%	1.7%	575
Huila	20.7%	25.9%	20.9%	31.4%	1.0%	5160
Ibagué	20.0%	23.1%	18.4%	37.5%	1.2%	4329
Ipiales	14.7%	20.8%	18.1%	45.2%	1.2%	1011
Itagüí	18.6%	27.8%	21.4%	30.6%	1.5%	1498
Jamundí	19.5%	27.3%	23.6%	28.0%	1.5%	885
La Guajira	22.9%	27.8%	21.5%	26.4%	1.4%	1790
Lorica	25.6%	27.2%	24.5%	22.3%	0.4%	1167
Magangué	20.4%	26.0%	21.6%	27.2%	4.8%	903
Magdalena	24.7%	29.5%	21.4%	22.8%	1.6%	5178
Maicao	23.9%	28.7%	21.2%	25.4%	0.7%	1132
Malambo	23.8%	29.4%	15.8%	30.0%	1.1%	837
Manizales	17.4%	26.3%	20.9%	34.7%	0.7%	2878
Medellín	18.6%	24.1%	20.7%	35.0%	1.5%	16966
Meta	19.1%	27.7%	21.8%	30.7%	0.8%	3388
Montería	23.0%	24.4%	20.0%	31.3%	1.3%	3981
Mosquera	20.7%	24.6%	16.7%	37.3%	0.7%	1037
Nariño	19.3%	24.5%	19.3%	35.4%	1.6%	5979
Neiva	18.6%	23.9%	18.5%	38.2%	0.8%	3004
Norte de Santander	19.8%	24.6%	19.7%	34.9%	1.0%	4838
Palmira	19.4%	24.0%	18.4%	37.1%	1.2%	2248
Pasto	18.7%	21.2%	18.4%	40.1%	1.7%	3679
Pereira	18.6%	24.7%	19.8%	36.0%	1.0%	3671
Piedecuesta	17.0%	20.2%	16.2%	45.7%	0.9%	1187
Pitalito	20.0%	25.8%	18.8%	34.8%	0.6%	1112
Popayán	14.7%	25.1%	19.0%	39.4%	1.8%	2345
Putumayo	19.1%	25.3%	20.7%	33.5%	1.4%	2502
Quibdó	22.5%	28.0%	23.0%	24.3%	2.1%	1233
Quindío	20.8%	28.3%	22.1%	28.1%	0.8%	2071
Riohacha	23.1%	30.3%	19.3%	26.5%	0.9%	1323
Rionegro	17.5%	21.5%	18.5%	41.6%	0.8%	1074
Risaralda	22.6%	25.4%	22.0%	29.3%	0.7%	1908
Sabaneta	14.3%	21.0%	14.5%	43.4%	6.9%	525
Sahagún	22.6%	25.3%	22.4%	29.1%	0.6%	1089
San Andrés	22.5%	30.1%	20.7%	24.3%	2.4%	449
Santa Marta	21.2%	28.6%	21.1%	27.7%	1.4%	4139
Santander	16.8%	24.6%	19.5%	38.5%	0.6%	6241

Continúa en la siguiente página

ETC/País	A	B	C	D	Omisión y multimarca	N° estudiantes
Sincelejo	24.1%	23.6%	20.0%	31.6%	0.7%	2462
Soacha	20.8%	24.6%	19.3%	34.1%	1.1%	4523
Sogamoso	15.6%	23.3%	17.9%	41.1%	2.2%	1361
Soledad	20.8%	25.6%	18.1%	34.3%	1.2%	3637
Sucre	25.3%	27.2%	20.7%	25.9%	1.0%	5370
Tolima	21.9%	26.9%	20.8%	28.8%	1.6%	6918
Tuluá	20.8%	25.6%	20.8%	32.2%	0.6%	1849
Tumaco	20.7%	31.2%	22.8%	24.0%	1.3%	1327
Tunja	17.0%	23.3%	17.3%	41.0%	1.4%	1487
Turbo	23.3%	28.8%	25.5%	20.1%	2.2%	999
Uribe	28.1%	27.1%	21.6%	21.2%	2.1%	292
Valle del Cauca	21.8%	24.9%	21.8%	29.3%	2.2%	6865
Valledupar	22.8%	23.7%	18.8%	29.3%	5.5%	3940
Vaupés	19.7%	36.2%	17.1%	23.7%	3.3%	152
Vichada	20.8%	30.1%	21.2%	26.4%	1.5%	269
Villavicencio	17.4%	23.0%	19.7%	38.8%	1.1%	3946
Yopal	18.1%	23.9%	18.9%	38.4%	0.7%	1271
Zipaquirá	18.3%	21.3%	19.0%	41.2%	0.3%	1108
Colombia	19.8%	24.8%	19.7%	34.2%	1.4%	366383

*Es posible que los porcentajes mostrados no sumen exactamente 100 debido a aproximaciones decimales.

• **Pregunta 3.**

La gráfica representa la distancia (en metros) recorrida por los atletas P , Q y R , en función del tiempo (en segundos) empleado por ellos durante una carrera de 100 metros.

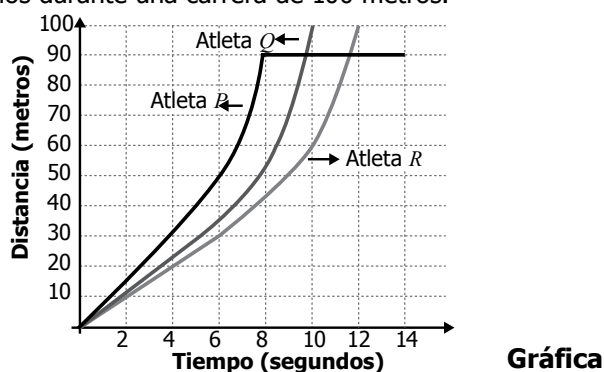

- | |
|--|
| <p>I. El atleta P recorrió solamente 90 metros.
 II. Los atletas Q y R llegaron al mismo tiempo.
 III. El primero en llegar a la meta fue el atleta Q.</p> |
|--|

¿Cuál o cuáles de las anteriores afirmaciones, sobre la carrera de los atletas P , Q y R , es o son verdadera(s)?

- A. II solamente.
- B. III solamente.
- C. I y II solamente.
- D. I y III solamente.

• **Estructura**

Competencia	Comunicación
Componente	Númerico - variacional
Afirmación	Establece relaciones entre propiedades de las gráficas y propiedades de las ecuaciones algebraicas.
Nivel de desempeño	Avanzado
Respuesta Correcta	D

• Resultados a nivel nacional y de Entidad Territorial Certificada (ETC)

ETC/País	A	B	C	D	Omisión y multimarca	N° estudiantes
Amazonas	19.2%	38.0%	22.6%	18.3%	1.9%	589
Antioquia	14.8%	34.3%	21.8%	26.5%	2.6%	16846
Apartadó	17.0%	37.5%	22.4%	22.7%	0.5%	1019
Arauca	15.7%	32.7%	21.9%	28.7%	1.0%	1614
Armenia	12.0%	31.3%	22.9%	33.3%	0.6%	2415
Atlántico	15.8%	36.0%	22.3%	24.4%	1.6%	4578
Barrancabermeja	12.4%	34.2%	22.6%	30.1%	0.7%	1899
Barranquilla	13.1%	35.1%	22.6%	28.1%	1.2%	9988
Bello	12.1%	32.1%	22.4%	32.5%	0.8%	3092
Bogotá, D.C.	9.9%	29.0%	22.9%	37.4%	0.9%	60321
Bolívar	18.9%	36.8%	23.4%	19.7%	1.3%	7070
Boyacá	13.0%	30.8%	25.0%	30.3%	0.8%	7298
Bucaramanga	9.1%	29.6%	21.3%	38.7%	1.2%	4681
Buenaventura	15.1%	40.8%	20.1%	22.7%	1.3%	2198
Buga	11.7%	36.4%	22.4%	27.6%	1.9%	884
Caldas	15.0%	35.5%	23.8%	25.0%	0.8%	4244
Cali	12.0%	32.2%	21.8%	32.5%	1.5%	16005
Caquetá	16.8%	36.2%	22.1%	22.6%	2.2%	1587
Cartagena	14.8%	33.4%	23.5%	26.3%	2.1%	8877
Cartago	13.3%	33.4%	25.1%	26.9%	1.3%	865
Casanare	12.3%	35.5%	23.2%	27.7%	1.3%	2075
Cauca	17.8%	35.7%	22.8%	21.9%	1.8%	7914
Cesar	17.0%	36.1%	24.0%	21.8%	1.1%	5112
Chocó	20.9%	40.6%	21.3%	15.7%	1.5%	1896
Chía	9.9%	26.1%	22.4%	41.2%	0.5%	1289
Ciénaga	18.0%	38.1%	24.4%	18.3%	1.3%	997
Cundinamarca	12.3%	31.7%	24.0%	30.6%	1.4%	13471
Córdoba	18.5%	35.8%	24.8%	19.6%	1.2%	8801
Cúcuta	12.3%	33.7%	21.9%	31.6%	0.4%	6040
Dosquebradas	10.8%	32.6%	24.1%	31.2%	1.2%	1265
Duitama	8.3%	22.3%	22.6%	46.1%	0.7%	1067
Envigado	9.1%	28.2%	20.0%	42.2%	0.5%	1677
Facatativá	10.7%	29.7%	25.1%	33.2%	1.3%	1064
Florencia	14.0%	33.2%	23.0%	29.5%	0.3%	1285
Floridablanca	10.1%	27.7%	20.0%	41.8%	0.5%	2014
Fusagasugá	12.3%	30.5%	22.6%	34.0%	0.6%	1228
Girardot	16.1%	36.7%	23.1%	23.5%	0.6%	901

Continúa en la siguiente página



ETC/País	A	B	C	D	Omisión y multimarca	Nº estudiantes
Girón	9.7%	29.8%	23.4%	36.1%	1.0%	945
Guainía	19.5%	41.5%	20.7%	17.7%	0.6%	164
Guaviare	15.8%	39.7%	18.6%	23.3%	2.6%	575
Huila	14.4%	33.2%	25.5%	25.8%	1.0%	5160
Ibagué	12.1%	34.4%	21.5%	31.2%	0.8%	4329
Ipiales	13.3%	26.9%	22.1%	37.0%	0.8%	1011
Itagüí	12.1%	32.1%	22.6%	31.5%	1.6%	1498
Jamundí	15.6%	33.2%	22.3%	28.4%	0.6%	885
La Guajira	18.1%	36.8%	21.8%	21.9%	1.4%	1790
Lorica	17.6%	38.6%	24.9%	17.9%	0.9%	1167
Magangué	15.4%	34.4%	22.9%	22.6%	4.7%	903
Magdalena	19.0%	38.4%	21.6%	19.4%	1.6%	5178
Maicao	18.0%	38.0%	24.0%	19.5%	0.4%	1132
Malambo	14.9%	33.5%	22.8%	27.5%	1.3%	837
Manizales	12.3%	32.2%	23.3%	31.4%	0.7%	2878
Medellín	12.3%	32.6%	21.5%	32.4%	1.4%	16966
Meta	14.3%	34.7%	23.8%	26.4%	0.8%	3388
Montería	14.4%	34.1%	24.6%	26.0%	0.9%	3981
Mosquera	9.4%	31.0%	19.7%	39.6%	0.4%	1037
Nariño	13.5%	31.0%	25.7%	28.8%	1.0%	5979
Neiva	12.1%	31.3%	23.3%	32.7%	0.7%	3004
Norte de Santander	14.8%	34.3%	23.2%	27.0%	0.7%	4838
Palmira	11.2%	31.0%	21.5%	35.3%	0.9%	2248
Pasto	10.1%	27.3%	27.5%	34.3%	0.8%	3679
Pereira	12.9%	30.7%	23.3%	32.4%	0.7%	3671
Piedecuesta	12.8%	32.6%	21.0%	33.3%	0.3%	1187
Pitalito	11.5%	30.2%	27.1%	30.5%	0.7%	1112
Popayán	11.0%	33.3%	21.8%	33.1%	0.8%	2345
Putumayo	14.3%	33.3%	25.7%	25.4%	1.2%	2502
Quibdó	17.5%	41.8%	20.3%	18.3%	2.0%	1233
Quindío	14.2%	32.6%	24.6%	27.9%	0.6%	2071
Riohacha	15.6%	39.8%	22.8%	21.5%	0.3%	1323
Rionegro	9.6%	32.0%	21.5%	36.2%	0.7%	1074
Risaralda	14.5%	36.5%	23.5%	24.9%	0.6%	1908
Sabaneta	9.1%	27.0%	17.7%	39.8%	6.3%	525
Sahagún	18.6%	34.3%	23.9%	22.9%	0.3%	1089
San Andrés	14.7%	31.6%	23.2%	28.1%	2.4%	449
Santa Marta	15.6%	38.0%	21.0%	23.9%	1.5%	4139
Santander	13.1%	32.4%	24.0%	30.1%	0.5%	6241

Continúa en la siguiente página

ETC/País	A	B	C	D	Omisión y multimarca	N° estudiantes
Sincelejo	13.7%	33.8%	24.4%	27.1%	1.0%	2462
Soacha	11.2%	34.1%	22.8%	31.2%	0.8%	4523
Sogamoso	8.6%	26.6%	25.9%	36.8%	2.1%	1361
Soledad	13.1%	34.5%	25.1%	26.4%	0.9%	3637
Sucre	19.1%	36.6%	23.8%	19.5%	1.0%	5370
Tolima	16.5%	36.0%	23.8%	22.4%	1.4%	6918
Tuluá	12.6%	33.6%	23.1%	30.2%	0.4%	1849
Tumaco	19.9%	37.5%	22.5%	19.3%	0.9%	1327
Tunja	8.5%	28.3%	23.2%	38.5%	1.5%	1487
Turbo	21.0%	40.0%	21.1%	15.8%	2.0%	999
Uribe	15.8%	45.5%	20.9%	17.1%	0.7%	292
Valle del Cauca	14.7%	34.5%	23.2%	25.7%	1.9%	6865
Valledupar	15.2%	33.6%	21.4%	24.6%	5.2%	3940
Vaupés	15.8%	36.2%	16.4%	27.6%	3.9%	152
Vichada	16.7%	36.8%	21.6%	24.5%	0.4%	269
Villavicencio	11.1%	32.0%	23.8%	32.2%	0.9%	3946
Yopal	10.9%	33.4%	21.7%	33.3%	0.6%	1271
Zipaquirá	10.1%	30.0%	26.0%	33.8%	0.1%	1108
Colombia	13.3%	32.9%	23.0%	29.5%	1.2%	366383

*Es posible que los porcentajes mostrados no sumen exactamente 100 debido a aproximaciones decimales.

• **Pregunta 4.**

La gráfica muestra el consumo de agua, en metros cúbicos (m^3), de tres viviendas en 7 bimestres.

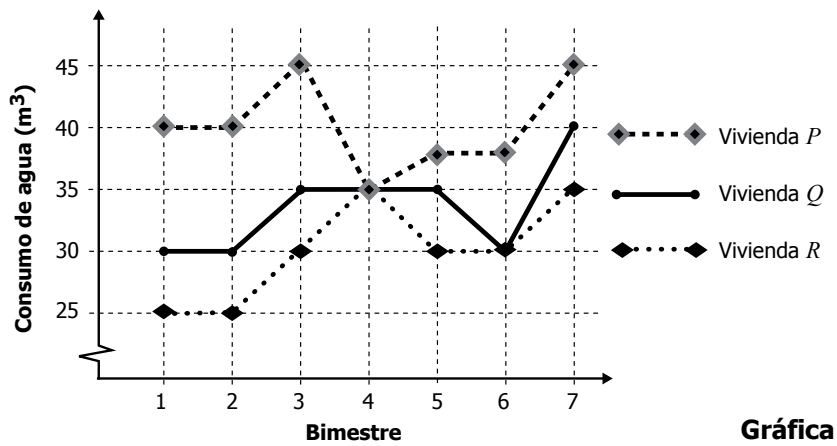

Gráfica

¿En cuál de los bimestres las tres viviendas consumieron la misma cantidad de agua?

- A. en el 2.
- B. en el 4.
- C. en el 6.
- D. en el 7.

• **Estructura**

Competencia	Comunicación
Componente	Numérico - variacional
Afirmación	Establece relaciones entre propiedades de las gráficas y propiedades de las ecuaciones algebraicas.
Nivel de desempeño	Mínimo
Respuesta Correcta	B

• Resultados a nivel nacional y de Entidad Territorial Certificada (ETC)

ETC	A	B	C	D	Omisión y multimarca	N° estudiantes
Amazonas	14.8%	50.4%	13.1%	19.5%	2.2%	589
Antioquia	17.1%	59.0%	9.7%	11.6%	2.6%	16846
Apartadó	17.0%	55.5%	13.8%	13.0%	0.7%	1019
Arauca	15.1%	65.5%	8.7%	10.0%	0.7%	1614
Armenia	13.2%	66.7%	9.5%	10.0%	0.5%	2415
Atlántico	16.9%	54.6%	12.6%	14.3%	1.6%	4578
Barrancabermeja	18.5%	62.3%	9.1%	9.6%	0.5%	1899
Barranquilla	14.6%	65.8%	9.5%	8.9%	1.3%	9988
Bello	17.2%	64.8%	7.6%	9.5%	0.9%	3092
Bogotá, D.C.	12.1%	74.9%	5.6%	6.5%	0.8%	60321
Bolívar	17.8%	50.2%	14.0%	16.5%	1.5%	7070
Boyacá	15.4%	68.3%	6.9%	8.6%	0.8%	7298
Bucaramanga	13.5%	74.1%	5.7%	5.5%	1.2%	4681
Buenaventura	18.7%	52.6%	12.1%	14.8%	1.7%	2198
Buga	15.5%	64.5%	9.2%	9.0%	1.8%	884
Caldas	16.3%	62.0%	9.3%	11.5%	0.9%	4244
Cali	13.9%	66.9%	8.6%	9.1%	1.5%	16005
Caquetá	16.1%	58.8%	10.8%	12.3%	2.0%	1587
Cartagena	16.8%	59.9%	9.9%	11.5%	1.9%	8877
Cartago	17.7%	60.2%	10.2%	10.5%	1.4%	865
Casanare	16.3%	64.0%	9.0%	9.4%	1.3%	2075
Cauca	15.9%	58.3%	10.8%	13.1%	1.8%	7914
Cesar	18.9%	54.1%	12.0%	13.8%	1.1%	5112
Chocó	18.1%	43.2%	16.1%	20.9%	1.6%	1896
Chía	11.5%	77.5%	5.0%	5.6%	0.4%	1289
Ciénaga	20.4%	47.0%	13.9%	17.3%	1.4%	997
Cundinamarca	13.5%	70.8%	6.3%	7.9%	1.5%	13471
Córdoba	16.7%	53.0%	13.4%	15.9%	1.1%	8801
Cúcuta	14.4%	68.4%	7.4%	9.4%	0.4%	6040
Dosquebradas	13.7%	70.4%	7.1%	7.7%	1.0%	1265
Duitama	10.5%	78.2%	6.1%	4.7%	0.6%	1067
Envigado	12.5%	72.9%	7.9%	6.4%	0.3%	1677
Facatativá	12.7%	72.1%	5.9%	8.5%	0.8%	1064
Florencia	14.6%	67.2%	7.6%	10.4%	0.2%	1285
Floridablanca	13.5%	72.6%	6.5%	7.0%	0.4%	2014
Fusagasugá	15.3%	71.7%	6.0%	6.6%	0.4%	1228
Girardot	16.9%	57.7%	11.2%	13.8%	0.4%	901

Continúa en la siguiente página



ETC	A	B	C	D	Omisión y multimarca	N° estudiantes
Girón	13.9%	71.4%	7.2%	6.3%	1.2%	945
Guainía	16.5%	53.7%	12.8%	17.1%	0.0%	164
Guaviare	14.8%	58.1%	9.6%	15.1%	2.4%	575
Huila	15.5%	64.1%	8.5%	10.8%	1.0%	5160
Ibagué	13.1%	70.0%	7.4%	8.7%	0.8%	4329
Ipiales	14.4%	69.4%	5.4%	10.2%	0.5%	1011
Itagüí	17.2%	57.5%	11.7%	12.3%	1.3%	1498
Jamundí	17.3%	63.3%	8.1%	10.8%	0.5%	885
La Guajira	17.7%	52.5%	13.2%	15.3%	1.4%	1790
Lorica	16.5%	52.2%	15.4%	15.3%	0.5%	1167
Magangué	18.3%	53.5%	9.7%	13.8%	4.7%	903
Magdalena	18.8%	47.6%	13.6%	18.6%	1.5%	5178
Maicao	17.3%	52.7%	12.8%	16.2%	1.1%	1132
Malambo	13.7%	64.0%	11.2%	9.8%	1.2%	837
Manizales	14.2%	67.8%	8.4%	8.9%	0.6%	2878
Medellín	16.1%	63.7%	9.4%	9.4%	1.4%	16966
Meta	13.6%	65.3%	9.7%	10.6%	0.8%	3388
Montería	14.3%	63.0%	9.2%	12.6%	0.9%	3981
Mosquera	13.4%	75.7%	4.7%	5.9%	0.3%	1037
Nariño	15.2%	64.3%	8.1%	11.2%	1.2%	5979
Neiva	13.5%	69.6%	7.3%	9.0%	0.6%	3004
Norte de Santander	16.3%	64.4%	8.1%	10.5%	0.7%	4838
Palmira	14.1%	70.0%	7.2%	7.7%	1.1%	2248
Pasto	13.3%	71.8%	6.3%	7.8%	0.8%	3679
Pereira	14.6%	69.2%	6.9%	8.7%	0.7%	3671
Piedecuesta	12.0%	72.5%	8.1%	7.0%	0.4%	1187
Pitalito	15.4%	67.6%	7.4%	9.4%	0.3%	1112
Popayán	13.9%	70.5%	7.8%	7.2%	0.6%	2345
Putumayo	13.4%	65.3%	8.7%	11.2%	1.4%	2502
Quibdó	18.0%	48.9%	14.3%	16.6%	2.2%	1233
Quindío	14.6%	64.7%	9.6%	10.7%	0.5%	2071
Riohacha	15.8%	57.7%	11.4%	14.9%	0.2%	1323
Rionegro	13.1%	68.7%	8.9%	8.5%	0.7%	1074
Risaralda	15.9%	61.8%	10.7%	11.2%	0.4%	1908
Sabaneta	14.7%	68.2%	4.2%	6.3%	6.7%	525
Sahagún	14.8%	62.1%	10.0%	12.9%	0.3%	1089
San Andrés	17.4%	54.8%	14.0%	11.4%	2.4%	449
Santa Marta	17.0%	58.2%	11.6%	11.8%	1.4%	4139
Santander	15.3%	68.9%	6.7%	8.6%	0.4%	6241

Continúa en la siguiente página

ETC	A	B	C	D	Omisión y multimarca	N° estudiantes
Sincelejo	16.2%	61.7%	9.8%	11.6%	0.7%	2462
Soacha	14.8%	68.4%	7.7%	8.3%	0.8%	4523
Sogamoso	11.7%	75.6%	5.0%	5.8%	1.9%	1361
Soledad	15.6%	61.3%	10.6%	11.7%	0.9%	3637
Sucre	16.3%	53.6%	13.0%	16.1%	1.0%	5370
Tolima	16.1%	58.9%	10.1%	13.5%	1.5%	6918
Tuluá	15.2%	66.5%	9.0%	9.1%	0.2%	1849
Tumaco	18.0%	49.1%	14.2%	17.1%	1.6%	1327
Tunja	10.6%	77.3%	4.8%	5.9%	1.3%	1487
Turbo	21.2%	46.1%	14.8%	15.6%	2.2%	999
Uribe	13.0%	50.7%	17.1%	18.5%	0.7%	292
Valle del Cauca	16.1%	60.7%	9.7%	11.5%	2.0%	6865
Valledupar	14.9%	58.1%	10.9%	10.9%	5.2%	3940
Vaupés	11.8%	63.8%	9.9%	11.2%	3.3%	152
Vichada	21.2%	55.4%	10.4%	11.9%	1.1%	269
Villavicencio	12.6%	72.0%	7.2%	7.4%	0.9%	3946
Yopal	12.5%	72.4%	6.7%	7.8%	0.6%	1271
Zipaquirá	13.6%	72.9%	5.7%	7.6%	0.2%	1108
Colombia	14.9%	65.0%	8.8%	10.2%	1.2%	366383

*Es posible que los porcentajes mostrados no sumen exactamente 100 debido a aproximaciones decimales.

• **Pregunta 5.**

La siguiente gráfica representa el número de horas diarias que un grupo de estudiantes navega en internet.

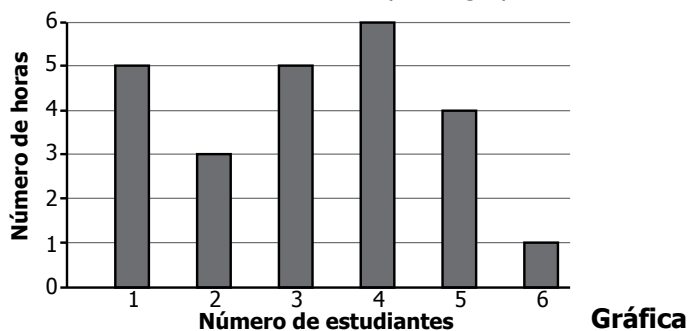

¿Cuál de las siguientes tablas representa correctamente la información de la gráfica?

A.

Número de estudiantes	Número de horas
1	1
2	0
3	1
4	1
5	2
6	1

B.

Número de estudiantes	Número de horas
1	5
2	3
3	5
4	6
5	4
6	1

C.

Número de estudiantes	Número de horas
5	1
3	2
5	3
6	4
4	5
1	6

D.

Número de estudiantes	Número de horas
1	1
0	2
1	3
1	4
2	5
1	6

• **Estructura**

Competencia	Comunicación
Componente	Aleatorio
Afirmación	Reconocer relaciones entre diferentes representaciones de un conjunto de datos y analizar la pertinencia de la representación.
Nivel de desempeño	Mínimo
Respuesta Correcta	B

• Resultados a nivel nacional y de Entidad Territorial Certificada (ETC)

ETC/País	A	B	C	D	Omisión y multimarca	N° estudiantes
Amazonas	5.3%	72.7%	15.1%	4.8%	2.2%	589
Antioquia	4.2%	79.9%	9.2%	4.0%	2.6%	16846
Apartadó	5.7%	73.8%	14.3%	5.3%	0.9%	1019
Arauca	2.8%	88.2%	6.4%	2.0%	0.6%	1614
Armenia	4.0%	84.8%	7.7%	3.1%	0.4%	2415
Atlántico	5.7%	74.6%	12.1%	6.0%	1.6%	4578
Barrancabermeja	3.8%	84.8%	7.3%	3.5%	0.6%	1899
Barranquilla	3.6%	84.8%	7.3%	3.2%	1.1%	9988
Bello	3.3%	85.5%	6.8%	3.5%	0.9%	3092
Bogotá, D.C.	1.6%	91.4%	4.6%	1.6%	0.7%	60321
Bolívar	6.2%	71.7%	14.6%	6.2%	1.3%	7070
Boyacá	2.4%	88.6%	6.2%	1.9%	0.8%	7298
Bucaramanga	2.1%	91.6%	3.9%	1.3%	1.1%	4681
Buenaventura	6.4%	74.3%	12.2%	5.7%	1.3%	2198
Buga	3.6%	85.4%	6.4%	2.8%	1.7%	884
Caldas	3.3%	85.0%	7.9%	3.1%	0.7%	4244
Cali	3.0%	85.9%	7.0%	2.9%	1.2%	16005
Caquetá	3.2%	80.4%	11.3%	3.2%	2.0%	1587
Cartagena	4.7%	78.8%	10.5%	4.2%	1.7%	8877
Cartago	3.1%	85.9%	6.8%	3.2%	0.9%	865
Casanare	3.0%	87.5%	6.5%	1.8%	1.2%	2075
Cauca	4.3%	78.5%	11.2%	4.4%	1.7%	7914
Cesar	5.3%	77.4%	11.8%	4.6%	1.0%	5112
Chocó	9.8%	61.6%	18.5%	8.8%	1.4%	1896
Chía	0.9%	93.1%	4.5%	1.1%	0.4%	1289
Ciénaga	7.4%	69.6%	15.2%	6.8%	0.9%	997
Cundinamarca	1.9%	89.9%	4.9%	1.9%	1.3%	13471
Córdoba	6.1%	71.9%	14.5%	6.4%	1.1%	8801
Cúcuta	2.5%	88.7%	6.3%	2.3%	0.2%	6040
Dosquebradas	1.7%	88.6%	6.3%	2.2%	1.1%	1265
Duitama	1.8%	92.9%	4.1%	0.5%	0.7%	1067
Envigado	2.7%	88.0%	6.0%	2.8%	0.5%	1677
Facatativá	1.6%	90.8%	5.4%	1.4%	0.8%	1064
Florencia	1.9%	88.8%	6.8%	2.3%	0.1%	1285
Floridablanca	1.9%	92.6%	4.1%	1.0%	0.4%	2014
Fusagasugá	1.3%	91.9%	4.4%	1.9%	0.6%	1228
Girardot	4.6%	82.8%	8.2%	3.9%	0.6%	901

Continúa en la siguiente página



ETC/País	A	B	C	D	Omisión y multimarca	N° estudiantes
Girón	1.6%	90.1%	5.5%	1.9%	1.0%	945
Guainía	4.9%	81.1%	11.0%	2.4%	0.6%	164
Guaviare	5.7%	78.8%	10.1%	3.7%	1.7%	575
Huila	2.5%	87.4%	7.1%	2.2%	0.8%	5160
Ibagué	2.1%	89.3%	5.5%	2.2%	0.8%	4329
Ipiales	1.7%	92.1%	4.0%	1.7%	0.6%	1011
Itagüí	6.7%	75.1%	10.9%	5.7%	1.5%	1498
Jamundí	2.8%	83.7%	10.4%	3.1%	0.0%	885
La Guajira	5.2%	75.6%	12.0%	5.6%	1.6%	1790
Lorica	8.0%	67.4%	16.5%	7.3%	0.8%	1167
Magangué	3.4%	75.4%	11.6%	5.1%	4.4%	903
Magdalena	7.2%	67.0%	16.9%	7.3%	1.6%	5178
Maicao	5.6%	76.2%	12.1%	5.6%	0.5%	1132
Malambo	4.8%	77.8%	12.1%	3.7%	1.7%	837
Manizales	2.8%	86.3%	6.8%	3.3%	0.7%	2878
Medellín	3.9%	82.2%	8.7%	3.9%	1.3%	16966
Meta	2.7%	86.5%	7.3%	2.8%	0.7%	3388
Montería	4.2%	81.8%	9.7%	3.5%	0.8%	3981
Mosquera	0.9%	92.5%	5.1%	1.3%	0.3%	1037
Nariño	3.0%	86.1%	7.6%	2.2%	1.1%	5979
Neiva	2.2%	90.9%	4.9%	1.6%	0.5%	3004
Norte de Santander	2.5%	86.4%	7.3%	3.0%	0.7%	4838
Palmira	3.1%	88.0%	5.6%	2.5%	0.8%	2248
Pasto	1.7%	92.2%	3.9%	1.4%	0.7%	3679
Pereira	2.2%	88.5%	5.9%	2.7%	0.6%	3671
Piedecuesta	2.2%	90.3%	5.3%	1.9%	0.3%	1187
Pitalito	1.3%	89.7%	6.6%	2.0%	0.4%	1112
Popayán	1.7%	91.0%	5.0%	1.8%	0.4%	2345
Putumayo	2.6%	86.2%	7.3%	2.7%	1.2%	2502
Quibdó	6.3%	69.1%	16.3%	6.5%	1.8%	1233
Quindío	3.5%	85.8%	7.1%	3.2%	0.4%	2071
Riohacha	4.7%	79.1%	11.1%	4.4%	0.8%	1323
Rionegro	2.3%	88.7%	4.9%	3.3%	0.7%	1074
Risaralda	3.2%	84.6%	7.5%	4.1%	0.6%	1908
Sabaneta	1.5%	86.7%	3.0%	2.5%	6.3%	525
Sahagún	4.7%	78.9%	11.8%	3.9%	0.7%	1089
San Andrés	7.3%	73.7%	10.9%	5.6%	2.4%	449
Santa Marta	5.0%	76.2%	11.8%	5.7%	1.2%	4139
Santander	1.9%	89.7%	6.1%	2.0%	0.4%	6241

Continúa en la siguiente página

ETC/País	A	B	C	D	Omisión y multimarca	N° estudiantes
Sincelejo	3.2%	83.5%	8.8%	3.9%	0.6%	2462
Soacha	2.3%	89.2%	5.6%	2.1%	0.8%	4523
Sogamoso	1.1%	91.8%	3.7%	1.2%	2.1%	1361
Soledad	4.0%	83.1%	8.8%	3.3%	0.8%	3637
Sucre	5.5%	74.6%	13.2%	5.8%	0.9%	5370
Tolima	3.6%	81.7%	9.8%	3.4%	1.4%	6918
Tuluá	2.6%	86.7%	7.2%	3.1%	0.3%	1849
Tumaco	7.4%	70.5%	15.1%	5.8%	1.3%	1327
Tunja	1.0%	92.7%	3.2%	1.7%	1.3%	1487
Turbo	6.4%	68.7%	16.2%	6.6%	2.1%	999
Uribia	4.8%	75.7%	14.7%	4.1%	0.7%	292
Valle del Cauca	3.5%	83.5%	8.0%	3.2%	1.8%	6865
Valledupar	4.1%	77.0%	10.2%	3.5%	5.2%	3940
Vaupés	5.9%	75.7%	11.2%	3.3%	3.9%	152
Vichada	4.8%	79.6%	9.7%	4.5%	1.5%	269
Villavicencio	3.0%	87.7%	6.0%	2.6%	0.7%	3946
Yopal	2.1%	91.7%	4.7%	1.0%	0.4%	1271
Zipaquirá	1.5%	92.0%	4.6%	1.8%	0.1%	1108
Colombia	3.3%	84.5%	7.9%	3.2%	1.1%	366383

*Es posible que los porcentajes mostrados no sumen exactamente 100 debido a aproximaciones decimales.

• Pregunta 6.

La tabla muestra información referente a las edades y al deporte practicado por un grupo de estudiantes de grado 9º de un colegio.

Edad (años)	Deporte practicado			Total
	Fútbol	Baloncesto	Voleibol	
13	10	3	9	22
14	6	1	12	19
15 ó más	2	2	15	19
Total	18	6	36	60

Tabla

Para la inauguración de los juegos intercurios del colegio, se debe elegir, al azar, uno de estos estudiantes para llevar la antorcha.

- I. La probabilidad de que el estudiante tenga 14 años es igual a la probabilidad de que tenga 15 ó más.
- II. La probabilidad de que el estudiante practique baloncesto es menor que la probabilidad de que practique voleibol.
- III. La probabilidad de que el estudiante tenga 13 años y practique voleibol es mayor que la probabilidad de que tenga 13 años y practique fútbol.

¿Cuál(es) de las anteriores afirmaciones es (son) verdadera(s)?

- A. I y II solamente.
- B. II y III solamente.
- C. I solamente.
- D. III solamente.

• Estructura

Competencia	Razonamiento
Componente	Aleatorio
Afirmación	Establecer conjeturas y verificar hipótesis acerca de los resultados de un experimento aleatorio usando conceptos básicos de probabilidad.
Nivel de desempeño	Satisfactorio
Respuesta Correcta	A

• Resultados a nivel nacional y de Entidad Territorial Certificada (ETC)

ETC/País	A	B	C	D	Omisión y multimarca	N° estudiantes
Amazonas	28.4%	22.2%	21.6%	26.0%	1.9%	589
Antioquia	36.2%	20.8%	21.0%	19.3%	2.8%	16846
Apartadó	35.5%	20.9%	21.3%	21.7%	0.6%	1019
Arauca	40.6%	19.4%	20.4%	18.6%	0.9%	1614
Armenia	43.0%	20.5%	20.6%	15.3%	0.7%	2415
Atlántico	35.3%	19.9%	22.3%	21.0%	1.6%	4578
Barrancabermeja	43.3%	20.6%	18.2%	17.0%	0.8%	1899
Barranquilla	44.8%	18.5%	19.3%	16.0%	1.5%	9988
Bello	42.1%	20.6%	20.6%	15.3%	1.4%	3092
Bogotá, D.C.	49.1%	18.2%	18.3%	13.4%	1.1%	60321
Bolívar	32.6%	21.9%	21.0%	22.9%	1.6%	7070
Boyacá	39.9%	20.2%	21.4%	17.5%	1.0%	7298
Bucaramanga	52.3%	16.4%	18.1%	11.8%	1.4%	4681
Buenaventura	37.2%	19.2%	20.3%	21.5%	1.8%	2198
Buga	40.6%	21.2%	23.6%	12.6%	2.0%	884
Caldas	38.0%	19.6%	21.3%	20.1%	0.9%	4244
Cali	44.8%	19.8%	18.9%	14.8%	1.7%	16005
Caquetá	32.2%	21.0%	24.3%	20.3%	2.3%	1587
Cartagena	40.8%	20.5%	19.4%	17.2%	2.1%	8877
Cartago	42.7%	19.9%	18.3%	17.6%	1.6%	865
Casanare	36.9%	21.9%	22.2%	17.5%	1.4%	2075
Cauca	31.3%	21.7%	21.6%	23.0%	2.3%	7914
Cesar	36.9%	20.2%	22.0%	19.5%	1.2%	5112
Chocó	26.4%	20.7%	23.7%	27.8%	1.3%	1896
Chía	52.4%	18.2%	17.4%	11.3%	0.6%	1289
Ciénaga	33.0%	19.5%	24.5%	21.9%	1.2%	997
Cundinamarca	41.9%	19.8%	20.0%	16.6%	1.7%	13471
Córdoba	31.6%	22.6%	21.5%	23.1%	1.3%	8801
Cúcuta	43.8%	18.7%	20.6%	16.2%	0.6%	6040
Dosquebradas	45.1%	19.5%	19.0%	15.5%	0.9%	1265
Duitama	56.7%	15.7%	16.7%	10.1%	0.8%	1067
Envigado	55.8%	16.2%	16.1%	11.1%	0.8%	1677
Facatativá	42.0%	20.8%	20.5%	15.6%	1.1%	1064
Florencia	40.5%	20.8%	20.5%	17.9%	0.3%	1285
Floridablanca	53.5%	16.2%	16.9%	13.0%	0.4%	2014
Fusagasugá	45.9%	19.7%	19.5%	14.2%	0.7%	1228
Girardot	38.0%	17.3%	24.1%	20.2%	0.4%	901

Continúa en la siguiente página



ETC/País	A	B	C	D	Omisión y multimarca	N° estudiantes
Girón	46.5%	19.6%	19.2%	13.2%	1.6%	945
Guainía	31.1%	20.7%	23.2%	23.2%	1.8%	164
Guaviare	31.0%	21.7%	23.8%	21.4%	2.1%	575
Huila	37.2%	21.3%	20.9%	19.4%	1.2%	5160
Ibagué	45.4%	20.4%	18.6%	14.6%	1.1%	4329
Ipiales	41.8%	19.3%	21.0%	17.1%	0.8%	1011
Itagüí	39.4%	17.8%	21.4%	19.3%	2.1%	1498
Jamundí	39.4%	22.0%	21.4%	16.6%	0.6%	885
La Guajira	33.7%	21.3%	21.0%	22.1%	1.9%	1790
Lorica	32.6%	22.8%	21.4%	22.4%	0.8%	1167
Magangué	35.8%	19.3%	18.7%	21.4%	4.9%	903
Magdalena	31.0%	20.8%	22.5%	24.2%	1.5%	5178
Maicao	32.5%	19.9%	24.2%	22.4%	1.0%	1132
Malambo	43.7%	18.9%	18.4%	17.8%	1.2%	837
Manizales	44.9%	20.2%	19.0%	15.1%	0.8%	2878
Medellín	43.0%	19.6%	19.5%	16.3%	1.6%	16966
Meta	37.5%	18.9%	22.8%	19.7%	1.1%	3388
Montería	40.8%	21.7%	19.3%	17.1%	1.1%	3981
Mosquera	47.5%	18.1%	20.3%	13.5%	0.5%	1037
Nariño	37.1%	22.4%	20.0%	19.3%	1.3%	5979
Neiva	45.7%	17.9%	18.8%	16.6%	1.0%	3004
Norte de Santander	39.1%	20.3%	20.5%	19.2%	0.8%	4838
Palmira	46.1%	18.6%	19.1%	14.7%	1.4%	2248
Pasto	45.9%	19.3%	18.6%	15.0%	1.3%	3679
Pereira	45.5%	18.6%	19.0%	15.8%	1.1%	3671
Piedecuesta	49.6%	18.0%	17.1%	14.2%	1.0%	1187
Pitalito	39.8%	21.1%	22.1%	16.2%	0.7%	1112
Popayán	45.8%	19.4%	17.7%	16.1%	0.9%	2345
Putumayo	34.5%	20.7%	22.1%	21.2%	1.5%	2502
Quibdó	32.8%	20.6%	22.0%	22.4%	2.2%	1233
Quindío	40.5%	19.7%	19.9%	19.1%	0.9%	2071
Riohacha	39.0%	18.6%	21.7%	20.0%	0.7%	1323
Rionegro	47.0%	17.9%	19.4%	14.3%	1.4%	1074
Risaralda	38.9%	22.5%	20.3%	17.5%	0.7%	1908
Sabaneta	51.2%	16.0%	16.0%	10.5%	6.3%	525
Sahagún	36.0%	21.9%	21.0%	20.8%	0.4%	1089
San Andrés	33.4%	22.0%	23.2%	18.7%	2.7%	449
Santa Marta	36.3%	20.2%	22.1%	19.6%	1.8%	4139
Santander	41.4%	20.5%	20.0%	17.5%	0.6%	6241

Continúa en la siguiente página

ETC/País	A	B	C	D	Omisión y multimarca	N° estudiantes
Sincelejo	41.1%	21.0%	19.7%	17.5%	0.7%	2462
Soacha	40.3%	20.8%	21.4%	16.3%	1.1%	4523
Sogamoso	46.1%	19.5%	20.0%	12.2%	2.2%	1361
Soledad	41.0%	20.5%	20.3%	17.0%	1.2%	3637
Sucre	33.4%	21.9%	20.9%	22.8%	1.0%	5370
Tolima	34.0%	21.3%	21.3%	22.0%	1.5%	6918
Tuluá	42.1%	21.3%	17.8%	17.9%	0.8%	1849
Tumaco	28.6%	21.8%	22.8%	25.5%	1.3%	1327
Tunja	50.6%	16.8%	18.1%	12.9%	1.6%	1487
Turbo	27.9%	22.0%	25.5%	22.3%	2.2%	999
Uribe	30.1%	18.5%	24.7%	25.7%	1.0%	292
Valle del Cauca	37.5%	21.5%	21.1%	17.8%	2.1%	6865
Valledupar	36.6%	20.1%	20.1%	18.0%	5.2%	3940
Vaupés	31.6%	19.7%	19.7%	24.3%	4.6%	152
Vichada	37.2%	17.8%	21.2%	23.8%	0.0%	269
Villavicencio	44.6%	19.8%	19.3%	15.3%	1.1%	3946
Yopal	46.3%	19.9%	19.4%	13.5%	0.9%	1271
Zipaquirá	47.1%	19.0%	20.0%	13.4%	0.4%	1108
Colombia	41.4%	19.9%	20.0%	17.3%	1.4%	366383

*Es posible que los porcentajes mostrados no sumen exactamente 100 debido a aproximaciones decimales.

• **Pregunta 7.**

En la figura aparecen, ubicadas sobre el hexágono regular $LTSRPN$, una región sombreada y la imagen que resulta de aplicarle a esta región un movimiento.

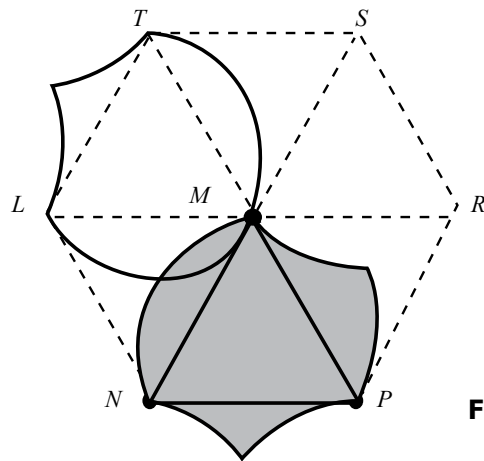

Figura

¿Cuál de los siguientes movimientos se aplicó a la región sombreada?

- A. Una reflexión sobre \overline{LR} .
- B. Una rotación de 120° con centro en M .
- C. Una reflexión sobre \overline{NS} .
- D. Una rotación de 30° con centro en L .

• **Estructura**

Competencia	Comunicación
Componente	Espacial - métrico
Afirmación	Identificar y describir efectos de transformaciones aplicadas a figuras planas.
Nivel de desempeño	Satisfactorio
Respuesta Correcta	B

• Resultados a nivel nacional y de Entidad Territorial Certificada (ETC)

ETC/País	A	B	C	D	Omisión y multimarca	N° estudiantes
Amazonas	12.6%	49.4%	19.5%	17.3%	1.2%	589
Antioquia	14.9%	47.2%	17.5%	17.7%	2.7%	16846
Apartadó	17.0%	45.9%	19.3%	17.0%	0.8%	1019
Arauca	13.0%	48.5%	19.6%	18.0%	0.9%	1614
Armenia	14.6%	51.3%	17.3%	15.9%	0.8%	2415
Atlántico	16.4%	45.9%	18.3%	17.6%	1.8%	4578
Barrancabermeja	17.3%	48.8%	16.9%	16.1%	0.9%	1899
Barranquilla	15.2%	48.8%	16.7%	17.6%	1.7%	9988
Bello	14.7%	52.0%	16.0%	16.1%	1.1%	3092
Bogotá, D.C.	12.2%	53.0%	16.1%	17.3%	1.3%	60321
Bolívar	17.8%	45.2%	19.0%	16.5%	1.5%	7070
Boyacá	13.7%	51.4%	16.3%	17.8%	0.8%	7298
Bucaramanga	11.6%	56.6%	15.4%	15.0%	1.5%	4681
Buenaventura	15.9%	49.7%	16.5%	16.2%	1.7%	2198
Buga	15.0%	49.8%	14.9%	18.2%	2.0%	884
Caldas	14.6%	51.1%	17.1%	16.4%	0.8%	4244
Cali	14.0%	51.1%	15.9%	17.1%	1.9%	16005
Caquetá	15.9%	47.1%	18.7%	15.9%	2.3%	1587
Cartagena	16.5%	47.7%	17.0%	16.7%	2.1%	8877
Cartago	14.3%	49.6%	16.6%	17.7%	1.7%	865
Casanare	12.7%	52.1%	17.4%	16.5%	1.3%	2075
Cauca	14.7%	47.7%	18.5%	17.2%	1.9%	7914
Cesar	16.2%	48.6%	16.4%	17.9%	1.0%	5112
Chocó	19.7%	42.9%	20.6%	15.3%	1.4%	1896
Chía	10.8%	53.9%	17.1%	17.3%	0.9%	1289
Ciénaga	17.7%	46.9%	16.9%	17.4%	1.2%	997
Cundinamarca	12.5%	52.2%	16.5%	17.0%	1.8%	13471
Córdoba	17.2%	45.4%	18.3%	18.0%	1.0%	8801
Cúcuta	14.4%	52.9%	16.6%	15.1%	0.9%	6040
Dosquebradas	14.8%	48.1%	16.9%	19.0%	1.3%	1265
Duitama	10.2%	59.0%	16.6%	13.4%	0.7%	1067
Envigado	14.2%	54.2%	15.7%	15.0%	0.8%	1677
Facatativá	10.0%	53.7%	16.9%	17.9%	1.6%	1064
Florencia	13.5%	52.6%	15.6%	18.1%	0.3%	1285
Floridablanca	13.2%	55.1%	16.4%	14.0%	1.2%	2014
Fusagasugá	12.0%	55.0%	14.5%	18.0%	0.5%	1228
Girardot	14.8%	48.4%	19.3%	16.8%	0.8%	901

Continúa en la siguiente página



ETC/País	A	B	C	D	Omisión y multimarca	N° estudiantes
Girón	12.5%	50.4%	17.1%	18.2%	1.8%	945
Guainía	11.6%	54.9%	18.9%	14.0%	0.6%	164
Guaviare	13.0%	49.9%	16.2%	19.0%	1.9%	575
Huila	14.1%	51.7%	17.6%	15.4%	1.2%	5160
Ibagué	13.5%	50.9%	17.0%	17.4%	1.2%	4329
Ipiales	11.7%	49.9%	17.5%	20.1%	0.9%	1011
Itagüí	23.0%	42.1%	17.1%	16.2%	1.6%	1498
Jamundí	15.5%	49.6%	15.0%	19.0%	0.9%	885
La Guajira	17.4%	46.3%	18.6%	16.4%	1.3%	1790
Lorica	18.2%	44.2%	17.8%	19.5%	0.3%	1167
Magangué	13.6%	46.1%	17.3%	17.9%	5.1%	903
Magdalena	18.3%	43.3%	19.4%	17.7%	1.4%	5178
Maicao	17.8%	44.5%	18.6%	18.5%	0.5%	1132
Malambo	13.9%	53.2%	15.2%	16.5%	1.3%	837
Manizales	13.0%	49.9%	17.8%	18.6%	0.8%	2878
Medellín	16.1%	48.7%	17.1%	16.6%	1.6%	16966
Meta	14.1%	49.9%	17.1%	17.9%	0.9%	3388
Montería	16.0%	49.2%	16.6%	17.1%	1.1%	3981
Mosquera	12.1%	52.6%	17.7%	16.7%	1.0%	1037
Nariño	14.3%	50.8%	16.6%	16.8%	1.5%	5979
Neiva	15.1%	52.3%	16.2%	15.7%	0.7%	3004
Norte de Santander	15.2%	50.7%	16.4%	16.8%	0.9%	4838
Palmira	12.9%	56.6%	14.0%	15.1%	1.4%	2248
Pasto	13.4%	50.6%	16.5%	18.1%	1.5%	3679
Pereira	14.5%	49.3%	18.9%	16.6%	0.9%	3671
Piedecuesta	15.8%	51.8%	15.6%	16.2%	0.6%	1187
Pitalito	15.2%	46.9%	17.9%	19.2%	0.8%	1112
Popayán	12.8%	54.7%	16.9%	14.3%	1.3%	2345
Putumayo	13.5%	50.9%	18.1%	15.9%	1.6%	2502
Quibdó	17.8%	40.9%	20.8%	18.2%	2.4%	1233
Quindío	15.4%	47.1%	17.2%	19.6%	0.7%	2071
Riohacha	14.9%	48.6%	16.8%	19.2%	0.5%	1323
Rionegro	13.6%	55.0%	15.4%	14.9%	1.1%	1074
Risaralda	12.6%	50.2%	16.5%	20.2%	0.4%	1908
Sabaneta	13.5%	46.5%	17.3%	15.8%	6.9%	525
Sahagún	18.8%	43.3%	17.9%	19.5%	0.5%	1089
San Andrés	22.7%	42.8%	19.8%	12.2%	2.4%	449
Santa Marta	16.5%	46.3%	17.3%	18.4%	1.4%	4139
Santander	14.5%	51.4%	16.8%	16.8%	0.5%	6241

Continúa en la siguiente página

ETC/País	A	B	C	D	Omisión y multimarca	N° estudiantes
Sincelejo	17.6%	48.2%	17.7%	15.7%	0.9%	2462
Soacha	13.4%	50.8%	17.1%	17.7%	1.1%	4523
Sogamoso	11.6%	52.2%	17.0%	17.0%	2.1%	1361
Soledad	15.9%	49.9%	16.3%	16.8%	1.1%	3637
Sucre	16.4%	47.4%	17.9%	17.2%	1.1%	5370
Tolima	15.1%	47.4%	18.8%	17.1%	1.5%	6918
Tuluá	14.0%	49.4%	16.5%	19.6%	0.4%	1849
Tumaco	15.6%	47.5%	17.7%	18.4%	0.8%	1327
Tunja	13.3%	54.3%	14.3%	16.7%	1.4%	1487
Turbo	16.9%	44.9%	16.7%	19.4%	2.0%	999
Uribe	16.8%	49.3%	14.4%	19.2%	0.3%	292
Valle del Cauca	14.1%	49.1%	17.3%	17.3%	2.1%	6865
Valledupar	14.5%	47.5%	16.1%	16.2%	5.7%	3940
Vaupés	16.4%	43.4%	17.8%	18.4%	3.9%	152
Vichada	12.3%	53.2%	19.3%	14.1%	1.1%	269
Villavicencio	14.6%	52.9%	15.9%	15.7%	1.0%	3946
Yopal	12.7%	57.0%	13.9%	15.7%	0.6%	1271
Zipaquirá	9.8%	57.5%	16.2%	15.8%	0.7%	1108
Colombia	14.5%	50.1%	16.9%	17.1%	1.4%	366383

*Es posible que los porcentajes mostrados no sumen exactamente 100 debido a aproximaciones decimales.

• **Pregunta 8.**

La tabla registra los porcentajes de erosión, humedad y nutrientes de un bosque que no ha sido intervenido por los humanos.

Característica	Porcentaje (%)
Erosión	20
Humedad	90
Nutrientes	100

Tabla

El diagrama que representa apropiadamente la información anterior es

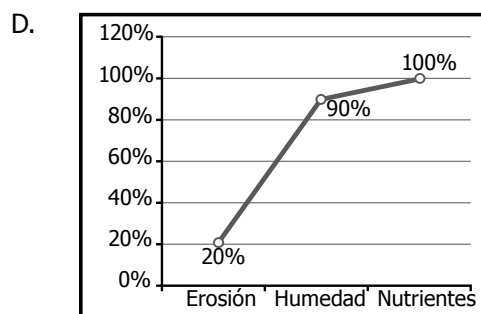
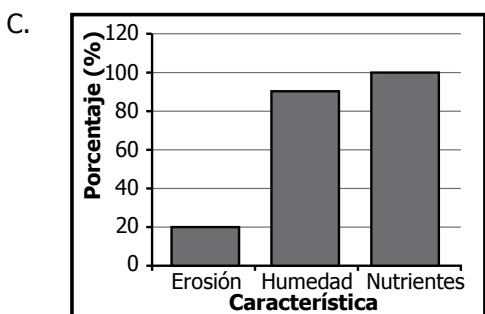
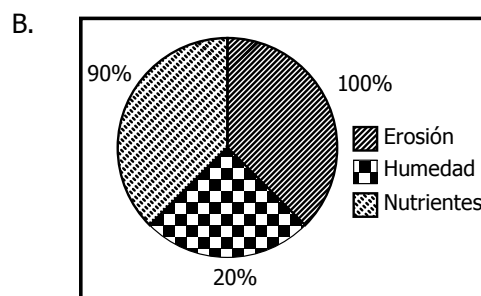
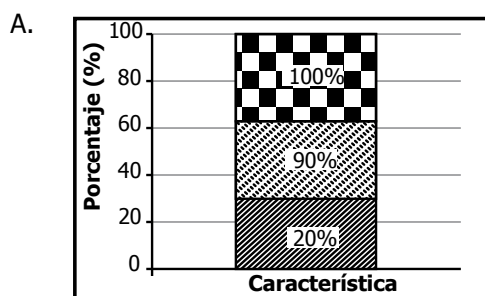

• **Estructura**

Competencia	Comunicación
Componente	Aleatorio
Afirmación	Reconocer relaciones entre diferentes representaciones de un conjunto de datos y analizar la pertinencia de la representación.
Nivel de desempeño	Satisfactorio
Respuesta Correcta	C

• Resultados a nivel nacional y de Entidad Territorial Certificada (ETC)

ETC/País	A	B	C	D	Omisión y multimarca	N° estudiantes
Amazonas	5.6%	18.2%	39.9%	34.5%	1.9%	589
Antioquia	4.5%	11.1%	54.2%	27.7%	2.5%	16846
Apartadó	7.0%	12.6%	50.5%	29.2%	0.7%	1019
Arauca	3.3%	9.2%	57.7%	29.2%	0.7%	1614
Armenia	4.6%	11.1%	57.2%	26.7%	0.4%	2415
Atlántico	6.7%	13.6%	49.5%	28.9%	1.3%	4578
Barrancabermeja	4.4%	10.9%	56.0%	28.1%	0.6%	1899
Barranquilla	3.9%	11.0%	56.7%	27.3%	1.1%	9988
Bello	3.8%	10.4%	58.0%	27.0%	0.8%	3092
Bogotá, D.C.	2.4%	8.4%	62.6%	25.9%	0.8%	60321
Bolívar	6.8%	13.6%	51.8%	26.5%	1.3%	7070
Boyacá	3.4%	8.0%	61.8%	26.1%	0.8%	7298
Bucaramanga	2.1%	6.7%	65.0%	25.2%	1.1%	4681
Buenaventura	5.8%	14.9%	47.0%	31.0%	1.3%	2198
Buga	4.1%	10.7%	54.4%	29.2%	1.6%	884
Caldas	4.1%	9.0%	58.9%	27.3%	0.7%	4244
Cali	3.7%	10.2%	57.0%	27.7%	1.3%	16005
Caquetá	5.5%	10.7%	53.8%	28.3%	1.7%	1587
Cartagena	5.4%	12.7%	53.0%	27.3%	1.7%	8877
Cartago	3.0%	11.2%	54.1%	30.6%	1.0%	865
Casanare	3.5%	8.7%	58.7%	27.9%	1.2%	2075
Cauca	5.0%	11.6%	51.7%	30.1%	1.6%	7914
Cesar	5.9%	12.4%	52.2%	28.5%	0.9%	5112
Chocó	9.7%	18.9%	43.6%	26.7%	1.1%	1896
Chía	2.5%	8.0%	62.5%	26.5%	0.5%	1289
Ciénaga	9.5%	13.2%	48.0%	28.2%	1.0%	997
Cundinamarca	2.8%	8.3%	60.1%	27.5%	1.3%	13471
Córdoba	6.8%	14.7%	48.4%	29.0%	1.1%	8801
Cúcuta	3.5%	8.8%	60.8%	26.5%	0.3%	6040
Dosquebradas	2.6%	10.4%	59.0%	27.1%	0.9%	1265
Duitama	1.7%	5.2%	71.6%	20.8%	0.7%	1067
Envigado	3.4%	9.1%	62.8%	24.3%	0.5%	1677
Facatativá	2.6%	7.3%	61.2%	27.9%	0.9%	1064
Florencia	3.4%	9.8%	58.4%	28.2%	0.2%	1285
Floridablanca	1.8%	8.0%	67.5%	22.4%	0.3%	2014
Fusagasugá	1.9%	9.4%	61.6%	26.7%	0.3%	1228
Girardot	5.9%	11.2%	53.3%	29.2%	0.4%	901

Continúa en la siguiente página



ETC/País	A	B	C	D	Omisión y multimarca	N° estudiantes
Girón	2.9%	7.4%	62.4%	26.5%	0.8%	945
Guainía	6.7%	11.0%	47.6%	34.8%	0.0%	164
Guaviare	4.5%	13.0%	50.3%	30.6%	1.6%	575
Huila	2.8%	9.0%	59.4%	27.8%	0.9%	5160
Ibagué	3.2%	9.0%	57.8%	29.3%	0.7%	4329
Ipiales	1.8%	5.9%	66.4%	25.1%	0.8%	1011
Itagüí	7.1%	14.0%	53.0%	24.6%	1.2%	1498
Jamundí	4.1%	10.5%	58.0%	27.1%	0.3%	885
La Guajira	5.8%	12.8%	52.4%	27.7%	1.4%	1790
Lorica	7.5%	17.2%	46.1%	29.0%	0.3%	1167
Magangué	5.4%	10.9%	52.4%	26.7%	4.7%	903
Magdalena	7.1%	15.2%	47.2%	28.9%	1.6%	5178
Maicao	5.8%	14.8%	48.9%	29.9%	0.5%	1132
Malambo	4.3%	10.4%	51.9%	32.4%	1.1%	837
Manizales	4.2%	9.2%	60.7%	25.3%	0.7%	2878
Medellín	4.5%	11.5%	56.2%	26.6%	1.2%	16966
Meta	4.3%	9.7%	56.9%	28.3%	0.7%	3388
Montería	4.5%	11.0%	55.0%	28.8%	0.7%	3981
Mosquera	2.3%	8.4%	60.1%	29.0%	0.2%	1037
Nariño	3.3%	8.7%	59.3%	27.6%	1.0%	5979
Neiva	2.8%	7.2%	63.4%	26.2%	0.4%	3004
Norte de Santander	3.9%	8.8%	59.3%	27.4%	0.7%	4838
Palmira	3.2%	11.3%	56.8%	28.0%	0.8%	2248
Pasto	2.5%	7.7%	63.5%	25.6%	0.7%	3679
Pereira	3.8%	9.4%	57.7%	28.4%	0.7%	3671
Piedecuesta	3.5%	8.4%	59.7%	28.0%	0.3%	1187
Pitalito	2.5%	9.4%	61.3%	26.3%	0.4%	1112
Popayán	2.9%	8.0%	60.7%	27.9%	0.4%	2345
Putumayo	4.0%	8.2%	57.3%	29.5%	1.0%	2502
Quibdó	7.3%	14.5%	48.1%	28.5%	1.6%	1233
Quindío	4.6%	9.9%	57.5%	27.6%	0.4%	2071
Riohacha	6.0%	12.8%	50.9%	29.9%	0.5%	1323
Rionegro	2.9%	9.6%	59.4%	27.5%	0.7%	1074
Risaralda	3.7%	10.0%	55.2%	30.6%	0.5%	1908
Sabaneta	2.3%	10.5%	54.7%	26.3%	6.3%	525
Sahagún	4.8%	12.2%	53.5%	29.3%	0.2%	1089
San Andrés	7.1%	17.1%	46.1%	27.6%	2.0%	449
Santa Marta	6.4%	12.7%	49.9%	30.0%	1.1%	4139
Santander	3.0%	7.5%	62.4%	26.8%	0.4%	6241

Continúa en la siguiente página

ETC/País	A	B	C	D	Omisión y multimarca	N° estudiantes
Sincelejo	4.1%	11.1%	56.3%	28.0%	0.5%	2462
Soacha	3.3%	9.5%	56.2%	30.1%	0.8%	4523
Sogamoso	1.4%	8.2%	65.3%	23.3%	1.8%	1361
Soledad	4.2%	10.3%	55.6%	29.3%	0.6%	3637
Sucre	6.1%	14.0%	49.7%	29.4%	0.7%	5370
Tolima	4.9%	11.0%	53.7%	29.1%	1.3%	6918
Tuluá	3.7%	11.4%	54.8%	30.0%	0.2%	1849
Tumaco	7.2%	15.1%	47.9%	28.9%	0.9%	1327
Tunja	2.4%	7.6%	69.5%	19.4%	1.2%	1487
Turbo	7.7%	15.6%	46.3%	28.2%	2.1%	999
Uribe	6.8%	11.6%	44.5%	36.3%	0.7%	292
Valle del Cauca	3.9%	10.9%	54.6%	28.9%	1.7%	6865
Vалledupar	4.4%	11.3%	51.7%	27.5%	5.1%	3940
Vaupés	2.0%	14.5%	50.7%	29.6%	3.3%	152
Vichada	3.3%	6.7%	48.3%	41.6%	0.0%	269
Villavicencio	2.6%	9.5%	60.1%	27.1%	0.6%	3946
Yopal	2.0%	8.1%	62.3%	27.1%	0.6%	1271
Zipaquirá	2.3%	10.0%	59.7%	28.0%	0.0%	1108
Colombia	4.0%	10.3%	57.2%	27.4%	1.1%	366383

*Es posible que los porcentajes mostrados no sumen exactamente 100 debido a aproximaciones decimales.

• **Pregunta 9.**

Cuando se aplican dos fuerzas verticales, hacia abajo, F_1 y F_2 a distancias respectivas, d_1 y d_2 , del punto de apoyo de una balanza y esta se encuentra en **equilibrio**, siempre se cumple que $F_1 \cdot d_1 = F_2 \cdot d_2$. La figura representa a un padre y a su hijo jugando en una balanza; el padre pesa 75 kilos y está sentado a 2 metros del punto de apoyo. ¿A qué distancia (en metros) del punto de apoyo debe sentarse el hijo que pesa 50 kilos, para que la balanza quede en **equilibrio**?

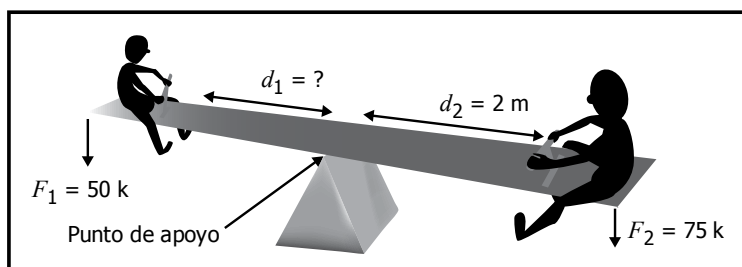

Figura

- A. 1
- B. 2
- C. 3
- D. 4

• **Estructura**

Competencia	Resolución
Componente	Numérico - variacional
Afirmación	Resolver problemas en situaciones de variación con funciones polinómicas y exponenciales en contextos aritméticos y geométricos.
Nivel de desempeño	Avanzado
Respuesta Correcta	C

• Resultados a nivel nacional y de Entidad Territorial Certificada (ETC)

ETC/País	A	B	C	D	Omisión y multimarca	N° estudiantes
Amazonas	22.8%	29.7%	30.1%	16.0%	1.5%	589
Antioquia	21.6%	24.7%	34.9%	16.1%	2.7%	16846
Apartadó	19.2%	29.2%	35.3%	15.1%	1.1%	1019
Arauca	23.0%	22.6%	38.5%	15.1%	0.8%	1614
Armenia	21.6%	23.7%	39.0%	15.1%	0.6%	2415
Atlántico	23.2%	28.7%	32.2%	14.2%	1.8%	4578
Barrancabermeja	21.2%	26.9%	37.7%	13.2%	1.0%	1899
Barranquilla	23.0%	25.2%	37.1%	13.0%	1.6%	9988
Bello	21.6%	23.2%	38.2%	15.7%	1.3%	3092
Bogotá, D.C.	21.1%	21.4%	43.9%	12.6%	1.1%	60321
Bolívar	24.4%	27.5%	30.2%	16.2%	1.8%	7070
Boyacá	23.3%	21.1%	41.3%	13.4%	0.9%	7298
Bucaramanga	21.6%	19.2%	46.0%	11.8%	1.4%	4681
Buenaventura	22.3%	26.5%	33.8%	15.7%	1.6%	2198
Buga	22.7%	24.2%	39.9%	11.3%	1.8%	884
Caldas	23.8%	23.8%	35.4%	16.1%	1.0%	4244
Calí	20.0%	24.1%	39.6%	14.4%	1.9%	16005
Caquetá	23.3%	23.6%	35.6%	15.5%	2.1%	1587
Cartagena	22.0%	26.4%	35.7%	13.6%	2.2%	8877
Cartago	19.8%	25.5%	39.9%	13.3%	1.5%	865
Casanare	22.1%	23.6%	38.6%	14.6%	1.2%	2075
Cauca	21.0%	26.1%	34.1%	16.6%	2.2%	7914
Cesar	23.4%	26.3%	33.9%	15.2%	1.2%	5112
Chocó	23.3%	29.1%	27.0%	18.7%	2.0%	1896
Chía	20.2%	19.2%	46.9%	13.2%	0.5%	1289
Ciénaga	24.8%	29.3%	29.8%	14.9%	1.2%	997
Cundinamarca	22.5%	22.0%	40.8%	13.3%	1.5%	13471
Córdoba	22.6%	27.7%	32.1%	16.6%	1.1%	8801
Cúcuta	22.2%	25.0%	40.5%	11.7%	0.6%	6040
Dosquebradas	19.1%	25.5%	40.9%	13.3%	1.3%	1265
Duitama	18.5%	17.4%	53.9%	9.6%	0.7%	1067
Envigado	19.1%	20.3%	48.5%	11.3%	0.7%	1677
Facatativá	23.6%	20.8%	38.4%	16.3%	0.9%	1064
Florencia	21.2%	23.2%	40.6%	14.9%	0.1%	1285
Floridablanca	20.2%	19.7%	48.1%	11.4%	0.7%	2014
Fusagasugá	21.7%	21.5%	42.6%	13.5%	0.7%	1228
Girardot	23.2%	28.1%	32.9%	15.1%	0.8%	901

Continúa en la siguiente página



ETC/País	A	B	C	D	Omisión y multimarca	N° estudiantes
Girón	19.8%	21.2%	44.8%	12.7%	1.6%	945
Guainía	26.2%	26.8%	28.0%	18.9%	0.0%	164
Guaviare	21.7%	25.7%	35.3%	15.0%	2.3%	575
Huila	22.5%	22.4%	39.2%	14.8%	1.1%	5160
Ibagué	22.5%	24.0%	38.3%	14.1%	1.1%	4329
Ipiales	20.7%	20.9%	45.4%	12.3%	0.8%	1011
Itagüí	21.3%	27.7%	35.7%	13.8%	1.5%	1498
Jamundí	24.6%	24.3%	34.6%	15.4%	1.1%	885
La Guajira	23.6%	29.4%	30.5%	15.0%	1.5%	1790
Lorica	23.8%	31.2%	27.2%	17.1%	0.7%	1167
Magangué	23.0%	26.1%	30.7%	15.4%	4.8%	903
Magdalena	24.1%	28.2%	30.0%	16.1%	1.7%	5178
Maicao	25.3%	28.6%	31.3%	14.1%	0.7%	1132
Malambo	24.0%	22.2%	36.4%	16.2%	1.1%	837
Manizales	21.4%	23.1%	38.8%	15.7%	1.0%	2878
Medellín	19.7%	23.7%	39.5%	15.4%	1.6%	16966
Meta	22.4%	23.6%	38.9%	14.1%	1.0%	3388
Montería	25.0%	24.5%	36.0%	13.6%	1.0%	3981
Mosquera	21.5%	20.4%	43.9%	13.5%	0.7%	1037
Nariño	20.1%	23.7%	39.7%	15.2%	1.4%	5979
Neiva	22.3%	23.6%	39.1%	14.0%	0.9%	3004
Norte de Santander	24.0%	25.5%	36.8%	13.0%	0.7%	4838
Palmira	21.1%	20.8%	43.1%	13.7%	1.2%	2248
Pasto	20.2%	22.8%	40.9%	14.8%	1.2%	3679
Pereira	20.1%	24.2%	40.1%	14.4%	1.1%	3671
Piedecuesta	22.8%	21.3%	40.4%	14.8%	0.6%	1187
Pitalito	21.5%	23.8%	37.9%	16.3%	0.5%	1112
Popayán	20.2%	22.1%	42.2%	14.1%	1.3%	2345
Putumayo	20.5%	25.6%	37.1%	15.5%	1.3%	2502
Quibdó	22.1%	29.0%	28.2%	18.7%	1.9%	1233
Quindío	22.8%	25.4%	35.0%	16.1%	0.7%	2071
Riohacha	26.3%	27.1%	31.6%	14.4%	0.6%	1323
Rionegro	20.9%	21.0%	42.0%	15.1%	0.9%	1074
Risaralda	22.3%	24.2%	38.1%	14.9%	0.5%	1908
Sabaneta	15.4%	17.0%	44.6%	16.2%	6.9%	525
Sahagún	25.4%	24.2%	33.1%	16.6%	0.6%	1089
San Andrés	21.4%	31.4%	30.3%	14.3%	2.7%	449
Santa Marta	22.4%	27.5%	34.6%	14.0%	1.5%	4139
Santander	23.4%	21.4%	41.1%	13.7%	0.4%	6241

Continúa en la siguiente página

ETC/País	A	B	C	D	Omisión y multimarca	N° estudiantes
Sincelejo	24.1%	25.8%	35.9%	13.4%	0.8%	2462
Soacha	22.4%	26.8%	36.5%	13.3%	1.0%	4523
Sogamoso	21.7%	21.2%	42.5%	12.3%	2.4%	1361
Soledad	23.3%	25.3%	36.8%	13.3%	1.3%	3637
Sucre	24.4%	27.2%	30.4%	16.9%	1.1%	5370
Tolima	23.8%	27.0%	33.6%	14.2%	1.5%	6918
Tuluá	21.7%	25.3%	37.9%	14.3%	0.9%	1849
Tumaco	22.8%	28.2%	32.1%	15.5%	1.4%	1327
Tunja	21.7%	18.7%	45.7%	12.6%	1.3%	1487
Turbo	23.9%	28.1%	28.7%	17.2%	2.0%	999
Uribe	17.1%	36.3%	26.7%	19.2%	0.7%	292
Valle del Cauca	21.7%	25.4%	36.7%	14.2%	2.0%	6865
Valledupar	21.3%	25.2%	34.5%	13.6%	5.4%	3940
Vaupés	19.7%	25.7%	27.6%	23.0%	3.9%	152
Vichada	22.7%	24.9%	34.9%	16.7%	0.7%	269
Villavicencio	22.6%	23.4%	40.9%	12.0%	1.1%	3946
Yopal	21.2%	24.6%	40.8%	12.6%	0.9%	1271
Zipaquirá	23.2%	18.3%	45.3%	12.6%	0.5%	1108
Colombia	21.9%	24.1%	38.4%	14.2%	1.4%	366383

*Es posible que los porcentajes mostrados no sumen exactamente 100 debido a aproximaciones decimales.

• **Pregunta 10.**

A continuación se muestra la forma de una zona territorial dibujada sobre una cuadrícula. Cada uno de los cuadrados de la cuadrícula representa 1 km^2 .

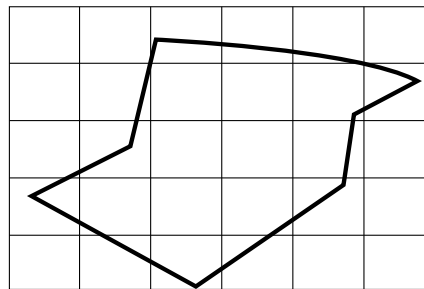

¿Cuál de las regiones sombreadas permite encontrar una aproximación más cercana a la medida del área de la zona territorial?

A.

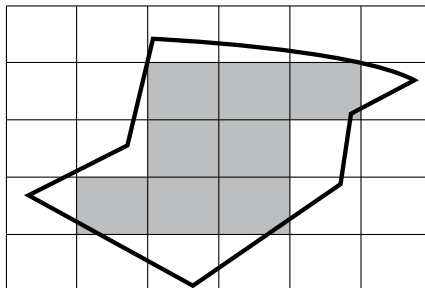

B.

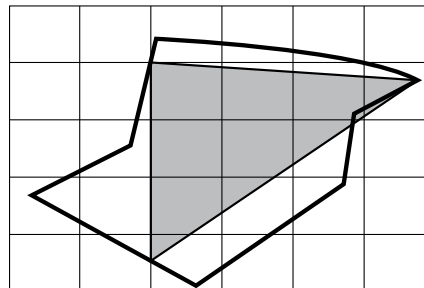

C.

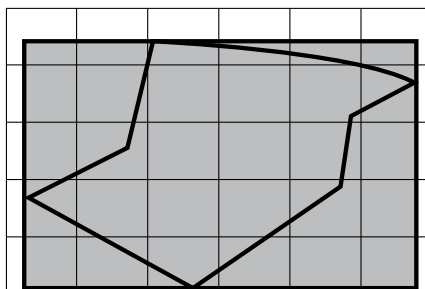

D.

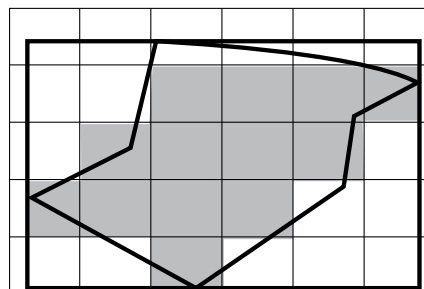

- Estructura

Competencia	Resolución
Componente	Espacial - métrico
Afirmación	Resolver y formular problemas geométricos o métricos que requieran seleccionar técnicas adecuadas de estimación o aproximación.
Nivel de desempeño	Avanzado
Respuesta Correcta	D

- Resultados a nivel nacional y de Entidad Territorial Certificada (ETC)

ETC/País	A	B	C	D	Omisión y multimarca	N° estudiantes
Amazonas	32.8%	16.1%	27.0%	21.6%	2.5%	589
Antioquia	32.4%	17.0%	21.9%	26.1%	2.6%	16846
Apartadó	31.0%	20.8%	21.6%	25.9%	0.7%	1019
Arauca	35.4%	16.2%	19.3%	28.1%	1.0%	1614
Armenia	33.5%	13.5%	19.3%	33.2%	0.5%	2415
Atlántico	36.9%	17.6%	20.7%	23.3%	1.6%	4578
Barrancabermeja	33.3%	17.1%	19.1%	29.6%	0.8%	1899
Barranquilla	35.1%	17.2%	17.6%	28.8%	1.4%	9988
Bello	32.1%	15.9%	19.0%	31.8%	1.1%	3092
Bogotá, D.C.	33.4%	12.7%	15.9%	37.1%	0.9%	60321
Bolívar	37.1%	18.6%	23.0%	19.6%	1.6%	7070
Boyacá	32.0%	14.6%	20.9%	31.6%	0.9%	7298
Bucaramanga	31.8%	13.3%	16.9%	36.8%	1.1%	4681
Buenaventura	34.6%	19.2%	21.7%	23.1%	1.4%	2198
Buga	30.2%	13.9%	19.9%	33.9%	2.0%	884
Caldas	34.2%	17.3%	21.5%	26.3%	0.7%	4244
Cali	34.1%	14.8%	18.2%	31.4%	1.6%	16005
Caquetá	34.0%	15.6%	25.5%	23.1%	1.8%	1587
Cartagena	35.7%	17.8%	18.0%	26.4%	2.1%	8877
Cartago	34.2%	15.1%	19.7%	29.7%	1.3%	865
Casanare	31.9%	13.9%	24.3%	28.4%	1.5%	2075
Cauca	33.0%	16.0%	26.4%	22.7%	2.0%	7914
Cesar	33.6%	19.7%	24.0%	21.6%	1.0%	5112
Chocó	37.4%	17.2%	27.6%	16.1%	1.6%	1896
Chía	28.7%	11.2%	17.9%	41.8%	0.4%	1289

Continúa en la siguiente página

ETC/País	A	B	C	D	Omisión y multimarca	N° estudiantes
Ciénaga	39.1%	18.2%	22.0%	19.8%	1.0%	997
Cundinamarca	31.7%	14.3%	19.6%	33.0%	1.5%	13471
Córdoba	34.0%	20.8%	24.6%	19.2%	1.3%	8801
Cúcuta	34.4%	16.1%	19.3%	29.8%	0.4%	6040
Dosquebradas	31.7%	14.3%	19.5%	33.0%	1.4%	1265
Duitama	29.3%	12.4%	18.6%	38.7%	1.0%	1067
Envigado	29.2%	12.4%	16.0%	42.0%	0.4%	1677
Facatativá	32.1%	12.6%	18.2%	35.9%	1.1%	1064
Florencia	31.4%	15.3%	24.1%	29.2%	0.0%	1285
Floridablanca	32.8%	11.9%	16.3%	38.2%	0.7%	2014
Fusagasugá	29.5%	12.6%	19.2%	38.1%	0.6%	1228
Girardot	35.4%	17.0%	20.8%	26.1%	0.8%	901
Girón	34.2%	14.5%	18.1%	31.5%	1.7%	945
Guainía	28.7%	21.3%	30.5%	19.5%	0.0%	164
Guaviare	29.0%	16.3%	26.8%	25.2%	2.6%	575
Huila	35.4%	15.3%	21.9%	26.4%	1.0%	5160
Ibagué	34.4%	14.7%	17.6%	32.3%	1.0%	4329
Ipiales	33.4%	15.2%	17.3%	33.3%	0.7%	1011
Itagüí	28.3%	18.4%	22.0%	29.6%	1.7%	1498
Jamundí	33.2%	17.5%	22.0%	27.1%	0.1%	885
La Guajira	35.0%	19.4%	22.9%	21.4%	1.3%	1790
Lorica	32.7%	24.7%	24.2%	17.8%	0.6%	1167
Magangué	36.3%	17.6%	21.2%	20.2%	4.8%	903
Magdalena	34.3%	20.3%	25.2%	18.4%	1.8%	5178
Maicao	34.6%	20.8%	21.9%	22.0%	0.7%	1132
Malambo	35.0%	19.0%	17.7%	27.0%	1.3%	837
Manizales	33.5%	15.8%	18.8%	31.3%	0.6%	2878
Medellín	30.4%	16.0%	19.7%	32.6%	1.4%	16966
Meta	31.3%	15.7%	22.8%	29.4%	0.8%	3388
Montería	37.0%	17.4%	20.4%	24.2%	1.0%	3981
Mosquera	32.9%	11.8%	17.2%	37.9%	0.3%	1037
Nariño	32.8%	16.0%	22.7%	27.3%	1.2%	5979
Neiva	32.9%	14.2%	21.8%	30.3%	0.8%	3004
Norte de Santander	33.2%	16.6%	22.0%	27.2%	0.9%	4838
Palmira	30.2%	14.5%	19.4%	34.5%	1.4%	2248
Pasto	33.2%	14.7%	18.4%	32.6%	1.1%	3679
Pereira	33.3%	13.5%	18.2%	34.2%	0.8%	3671
Piedecuesta	31.4%	15.8%	19.1%	33.1%	0.6%	1187
Pitalito	33.2%	14.8%	20.4%	31.1%	0.4%	1112

Continúa en la siguiente página

ETC/País	A	B	C	D	Omisión y multimarca	N° estudiantes
Popayán	31.0%	12.5%	20.5%	35.1%	0.9%	2345
Putumayo	31.3%	16.5%	22.9%	27.7%	1.5%	2502
Quibdó	35.3%	21.5%	22.9%	18.7%	1.7%	1233
Quindío	34.9%	16.0%	19.1%	29.5%	0.6%	2071
Riohacha	35.5%	18.7%	21.0%	23.8%	0.9%	1323
Rionegro	29.6%	13.3%	19.0%	37.2%	0.9%	1074
Risaralda	35.1%	16.5%	22.0%	25.9%	0.6%	1908
Sabaneta	29.3%	13.5%	15.4%	35.4%	6.3%	525
Sahagún	33.9%	22.4%	20.5%	22.7%	0.6%	1089
San Andrés	35.6%	17.6%	23.2%	21.4%	2.2%	449
Santa Marta	33.0%	17.5%	22.7%	25.6%	1.2%	4139
Santander	32.6%	14.7%	21.8%	30.3%	0.7%	6241
Sincedejo	35.1%	17.0%	20.5%	26.5%	0.9%	2462
Soacha	34.3%	14.7%	18.6%	31.4%	0.9%	4523
Sogamoso	32.0%	12.0%	19.0%	34.8%	2.1%	1361
Soledad	35.5%	18.7%	18.2%	26.8%	0.9%	3637
Sucre	36.3%	20.9%	23.2%	18.7%	0.9%	5370
Tolima	34.3%	17.7%	23.4%	23.2%	1.4%	6918
Tuluá	32.3%	15.7%	18.8%	32.8%	0.3%	1849
Tumaco	37.2%	22.1%	21.1%	17.9%	1.7%	1327
Tunja	33.7%	12.0%	15.5%	37.3%	1.5%	1487
Turbo	37.6%	19.6%	22.7%	17.9%	2.1%	999
Uribe	37.3%	18.2%	25.0%	18.8%	0.7%	292
Valle del Cauca	34.8%	16.9%	20.1%	26.5%	1.8%	6865
Valledupar	34.1%	16.7%	18.9%	24.8%	5.5%	3940
Vaupés	26.3%	15.1%	38.2%	17.1%	3.3%	152
Vichada	29.7%	19.7%	27.9%	22.7%	0.0%	269
Villavicencio	30.8%	15.2%	19.5%	33.7%	0.9%	3946
Yopal	31.7%	12.0%	22.8%	32.7%	0.8%	1271
Zipaquirá	32.9%	13.5%	18.9%	34.5%	0.3%	1108
Colombia	33.4%	15.8%	19.9%	29.6%	1.3%	366383

*Es posible que los porcentajes mostrados no sumen exactamente 100 debido a aproximaciones decimales.

• **Pregunta 11.**

La figura presenta una pirámide truncada de base cuadrada y uno de sus desarrollos planos.

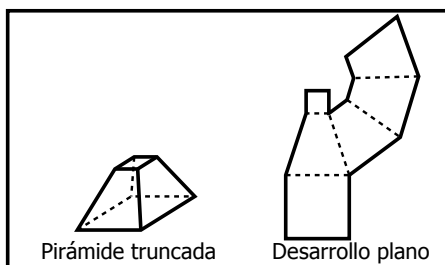

Figura

- I. Los 6 cuadriláteros que lo componen deben ser congruentes con las caras correspondientes de la pirámide truncada.
- II. Los 6 cuadriláteros que lo componen deben ser semejantes entre sí.
- III. La disposición de los 6 cuadriláteros debe permitir armar la pirámide sin traslapar.

¿Cuál o cuáles de las anteriores condiciones debe cumplir el desarrollo plano para poder armar la pirámide truncada?

- A. I solamente.
- B. II solamente.
- C. II y III solamente.
- D. I y III solamente.

• **Estructura**

Competencia	Razonamiento
Componente	Espacial - métrico
Afirmación	Analizar la validez o invalidez de usar procedimientos para la construcción de figuras planas y cuerpos con medidas dadas.
Nivel de desempeño	Avanzado
Respuesta Correcta	D

• Resultados a nivel nacional y de Entidad Territorial Certificada (ETC)

ETC/País	A	B	C	D	Omisión y multimarca	N° estudiantes
Amazonas	24.3%	20.4%	23.6%	29.9%	1.9%	589
Antioquia	23.1%	19.8%	22.1%	32.3%	2.7%	16846
Apartadó	23.3%	22.4%	23.4%	30.0%	1.0%	1019
Arauca	22.5%	20.5%	20.6%	35.2%	1.2%	1614
Armenia	21.6%	18.7%	22.9%	36.2%	0.5%	2415
Atlántico	24.3%	22.6%	21.1%	30.3%	1.8%	4578
Barrancabermeja	19.6%	18.5%	24.9%	35.9%	1.1%	1899
Barranquilla	22.8%	20.0%	22.7%	33.0%	1.4%	9988
Bello	21.5%	19.3%	22.3%	35.7%	1.1%	3092
Bogotá, D.C.	21.6%	16.3%	22.5%	38.5%	1.1%	60321
Bolívar	23.4%	22.7%	24.2%	28.3%	1.5%	7070
Boyacá	23.9%	19.4%	21.0%	34.7%	1.0%	7298
Bucaramanga	22.2%	16.7%	20.9%	38.7%	1.6%	4681
Buenaventura	23.5%	23.2%	21.5%	30.1%	1.8%	2198
Buga	25.8%	16.2%	21.5%	34.5%	2.0%	884
Caldas	24.7%	20.5%	22.0%	32.0%	0.8%	4244
Cali	22.8%	18.1%	22.5%	34.8%	1.8%	16005
Caquetá	23.8%	22.8%	20.7%	30.5%	2.2%	1587
Cartagena	23.2%	18.9%	24.3%	31.4%	2.3%	8877
Cartago	20.9%	21.7%	23.9%	32.0%	1.4%	865
Casanare	22.5%	18.4%	22.8%	35.0%	1.3%	2075
Cauca	24.1%	20.5%	22.1%	31.2%	2.1%	7914
Cesar	23.9%	23.4%	22.7%	28.7%	1.4%	5112
Chocó	23.9%	25.0%	25.1%	24.3%	1.8%	1896
Chía	21.8%	15.1%	23.4%	39.2%	0.5%	1289
Ciénaga	25.7%	24.4%	21.3%	27.5%	1.2%	997
Cundinamarca	23.1%	17.4%	21.6%	36.3%	1.5%	13471
Córdoba	23.7%	23.7%	23.3%	28.0%	1.2%	8801
Cúcuta	21.9%	18.4%	23.6%	35.4%	0.7%	6040
Dosquebradas	23.1%	19.2%	22.1%	34.1%	1.5%	1265
Duitama	18.9%	14.2%	23.2%	42.7%	0.8%	1067
Envigado	20.2%	16.4%	24.1%	38.5%	0.8%	1677
Facatativá	23.3%	15.9%	21.8%	38.2%	0.8%	1064
Florencia	21.4%	19.3%	22.7%	36.3%	0.2%	1285
Floridablanca	20.6%	17.4%	20.7%	40.7%	0.6%	2014
Fusagasugá	23.9%	15.1%	21.7%	38.5%	0.7%	1228
Girardot	25.6%	22.4%	22.9%	28.3%	0.8%	901

Continúa en la siguiente página

ETC/País	A	B	C	D	Omisión y multimarca	N° estudiantes
Girón	23.2%	15.4%	21.9%	38.1%	1.4%	945
Guainía	22.6%	26.8%	18.3%	32.3%	0.0%	164
Guaviare	25.9%	22.3%	19.8%	28.9%	3.1%	575
Huila	23.7%	18.7%	21.3%	35.2%	1.1%	5160
Ibagué	22.5%	18.2%	23.1%	35.2%	1.1%	4329
Ipiales	23.4%	18.7%	19.2%	37.9%	0.8%	1011
Itagüí	22.2%	21.1%	22.4%	32.4%	1.9%	1498
Jamundí	24.0%	18.2%	23.8%	33.6%	0.5%	885
La Guajira	24.0%	22.3%	23.5%	28.7%	1.6%	1790
Lorica	26.0%	25.2%	23.0%	25.2%	0.7%	1167
Magangué	23.1%	21.8%	20.8%	29.2%	5.0%	903
Magdalena	24.7%	24.8%	22.8%	25.9%	1.8%	5178
Maicao	26.6%	21.8%	23.1%	27.5%	1.0%	1132
Malambo	23.8%	20.8%	21.6%	31.9%	1.9%	837
Manizales	22.4%	18.6%	22.1%	36.0%	0.9%	2878
Medellín	21.8%	18.3%	23.9%	34.5%	1.5%	16966
Meta	23.6%	20.3%	21.7%	33.5%	0.9%	3388
Montería	22.6%	20.1%	23.8%	32.4%	1.1%	3981
Mosquera	23.8%	16.3%	21.7%	37.1%	1.1%	1037
Nariño	22.6%	17.8%	22.7%	35.5%	1.4%	5979
Neiva	23.1%	16.9%	21.8%	37.4%	0.8%	3004
Norte de Santander	22.6%	19.1%	22.3%	35.2%	0.8%	4838
Palmira	21.4%	19.1%	22.6%	35.5%	1.3%	2248
Pasto	21.6%	16.1%	21.4%	39.5%	1.4%	3679
Pereira	22.2%	18.1%	23.3%	35.3%	1.1%	3671
Piedecuesta	21.8%	16.4%	22.9%	38.5%	0.3%	1187
Pitalito	22.6%	18.1%	22.9%	36.0%	0.4%	1112
Popayán	22.6%	18.5%	21.1%	36.5%	1.4%	2345
Putumayo	22.0%	20.1%	21.9%	34.7%	1.4%	2502
Quibdó	23.3%	22.3%	23.4%	28.8%	2.3%	1233
Quindío	23.1%	18.5%	24.4%	33.5%	0.5%	2071
Riohacha	25.4%	22.3%	22.9%	28.6%	0.8%	1323
Rionegro	22.7%	18.4%	20.1%	37.4%	1.3%	1074
Risaralda	24.5%	20.4%	20.9%	33.7%	0.4%	1908
Sabaneta	22.5%	13.1%	21.9%	36.0%	6.5%	525
Sahagún	18.7%	22.5%	24.5%	33.4%	0.8%	1089
San Andrés	21.4%	23.8%	21.4%	30.7%	2.7%	449
Santa Marta	21.7%	22.7%	24.3%	29.8%	1.5%	4139
Santander	23.4%	18.1%	21.9%	35.7%	0.8%	6241

Continúa en la siguiente página

ETC/País	A	B	C	D	Omisión y multimarca	N° estudiantes
Sincelejo	23.9%	18.7%	23.3%	33.3%	0.9%	2462
Soacha	24.4%	18.8%	22.0%	33.7%	1.0%	4523
Sogamoso	23.5%	16.9%	19.9%	37.5%	2.1%	1361
Soledad	23.8%	20.3%	23.3%	31.5%	1.1%	3637
Sucre	23.5%	22.2%	24.0%	29.3%	1.0%	5370
Tolima	24.3%	19.7%	22.0%	32.6%	1.5%	6918
Tuluá	25.4%	17.8%	23.7%	32.7%	0.4%	1849
Tumaco	24.4%	21.8%	20.6%	31.8%	1.4%	1327
Tunja	21.0%	18.0%	21.7%	37.9%	1.5%	1487
Turbo	21.9%	24.3%	23.7%	27.5%	2.5%	999
Uribe	25.3%	21.6%	20.5%	32.2%	0.3%	292
Valle del Cauca	23.8%	20.1%	22.1%	32.1%	2.0%	6865
Valledupar	21.5%	19.4%	23.0%	30.6%	5.5%	3940
Vaupés	25.7%	17.8%	21.7%	30.9%	3.9%	152
Vichada	24.2%	20.8%	22.7%	32.0%	0.4%	269
Villavicencio	21.9%	17.9%	22.4%	36.7%	1.0%	3946
Yopal	23.4%	16.4%	19.9%	39.7%	0.6%	1271
Zipaquirá	20.3%	17.3%	20.7%	41.2%	0.5%	1108
Colombia	22.8%	19.0%	22.5%	34.2%	1.4%	366383

*Es posible que los porcentajes mostrados no sumen exactamente 100 debido a aproximaciones decimales.

• **Pregunta 12.**

Dos personas, M y N , acordaron encontrarse en una oficina. Para llegar a la oficina, la persona M debe caminar 5 cuadras al sur y después 2 al este; la persona N debe caminar 5 cuadras al oeste y después 3 al norte.

¿En cuál de los planos coordenados se representa correctamente la posición de las personas y de la oficina?

Nota: El lado de cada cuadrado de la cuadrícula representa 1 cuadra.

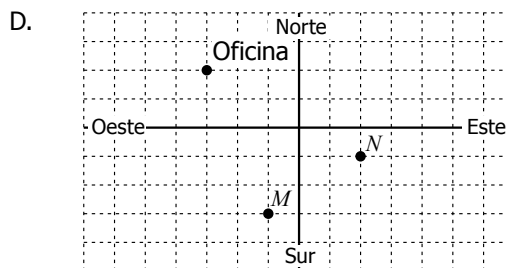
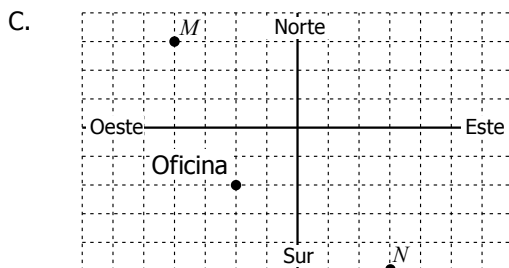
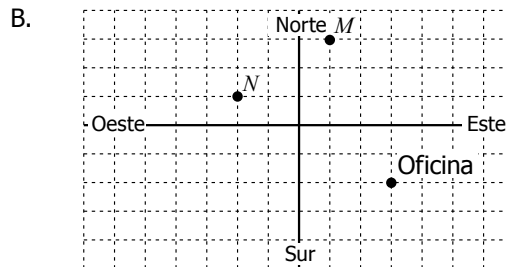
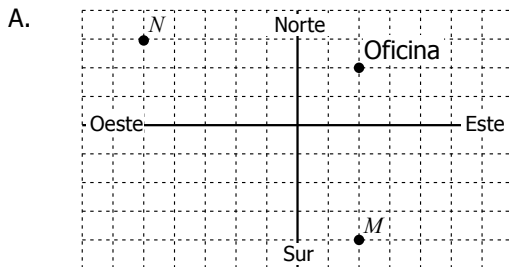

• **Estructura**

Competencia	Comunicación
Componente	Espacial - métrico
Afirmación	Identificar características de localización de objetos en sistemas de representación cartesiana y geográfica.
Nivel de desempeño	Satisfactorio
Respuesta Correcta	C

• Resultados a nivel nacional y de Entidad Territorial Certificada (ETC)

ETC/País	A	B	C	D	Omisión y multimarca	N° estudiantes
Amazonas	27.7%	18.7%	34.6%	16.5%	2.5%	589
Antioquia	25.9%	17.1%	39.7%	14.6%	2.7%	16846
Apartadó	25.0%	18.4%	38.6%	17.2%	0.9%	1019
Arauca	27.3%	13.6%	46.2%	12.1%	0.9%	1614
Armenia	24.1%	15.9%	46.7%	12.6%	0.6%	2415
Atlántico	24.2%	18.5%	38.2%	17.6%	1.5%	4578
Barrancabermeja	27.3%	16.1%	41.9%	14.0%	0.8%	1899
Barranquilla	24.1%	15.6%	46.2%	12.8%	1.3%	9988
Bello	25.2%	15.1%	46.6%	12.1%	1.1%	3092
Bogotá, D.C.	22.1%	11.8%	54.7%	10.3%	0.9%	60321
Bolívar	27.6%	19.8%	33.3%	17.7%	1.6%	7070
Boyacá	23.4%	15.2%	47.8%	12.6%	1.0%	7298
Bucaramanga	23.5%	11.5%	53.4%	10.4%	1.3%	4681
Buenaventura	28.3%	19.4%	34.4%	16.2%	1.6%	2198
Buga	22.6%	14.4%	50.0%	11.4%	1.6%	884
Caldas	26.5%	16.0%	42.5%	14.3%	0.8%	4244
Cali	24.7%	15.3%	45.2%	13.2%	1.7%	16005
Caquetá	26.4%	17.0%	40.7%	13.9%	2.0%	1587
Cartagena	26.0%	17.2%	40.3%	14.6%	1.9%	8877
Cartago	29.7%	13.2%	43.4%	12.5%	1.3%	865
Casanare	27.0%	13.6%	45.2%	13.0%	1.2%	2075
Cauca	28.3%	16.9%	36.9%	16.0%	2.0%	7914
Cesar	27.5%	17.6%	37.9%	15.6%	1.3%	5112
Chocó	31.1%	18.2%	31.6%	17.4%	1.7%	1896
Chía	24.4%	10.7%	54.6%	9.7%	0.5%	1289
Ciénaga	25.8%	18.9%	35.2%	18.9%	1.3%	997
Cundinamarca	24.0%	13.4%	49.2%	11.9%	1.5%	13471
Córdoba	27.8%	18.8%	34.7%	17.6%	1.2%	8801
Cúcuta	26.7%	13.7%	47.0%	12.1%	0.6%	6040
Dosquebradas	24.4%	13.6%	47.6%	13.2%	1.2%	1265
Duitama	19.6%	11.4%	59.3%	8.8%	0.8%	1067
Envigado	20.6%	12.3%	56.1%	10.4%	0.7%	1677
Facatativá	27.6%	11.3%	50.2%	9.8%	1.1%	1064
Florencia	27.1%	12.8%	47.4%	12.3%	0.5%	1285
Floridablanca	22.5%	11.9%	55.9%	9.2%	0.5%	2014
Fusagasugá	26.6%	10.7%	51.8%	10.2%	0.7%	1228
Girardot	24.4%	18.2%	39.7%	17.1%	0.6%	901

Continúa en la siguiente página



ETC/País	A	B	C	D	Omisión y multimarca	N° estudiantes
Girón	25.5%	14.0%	48.0%	11.3%	1.2%	945
Guainía	29.9%	15.2%	40.9%	13.4%	0.6%	164
Guaviare	22.3%	18.6%	38.3%	17.7%	3.1%	575
Huila	26.6%	15.4%	44.1%	12.8%	1.1%	5160
Ibagué	25.7%	13.6%	47.7%	12.0%	1.0%	4329
Ipiales	25.1%	12.1%	51.9%	10.2%	0.7%	1011
Itagüí	24.6%	14.8%	42.8%	15.9%	1.9%	1498
Jamundí	26.8%	14.9%	42.4%	15.1%	0.8%	885
La Guajira	26.9%	17.7%	36.6%	17.2%	1.6%	1790
Lorica	26.0%	19.6%	35.6%	18.1%	0.8%	1167
Magangué	24.5%	18.3%	34.2%	17.8%	5.2%	903
Magdalena	26.2%	19.7%	33.0%	19.0%	2.0%	5178
Maicao	25.3%	23.0%	35.3%	15.8%	0.6%	1132
Malambo	25.4%	16.2%	38.9%	17.6%	1.8%	837
Manizales	24.6%	14.0%	48.4%	12.2%	0.8%	2878
Medellín	22.9%	15.5%	46.9%	13.2%	1.5%	16966
Meta	22.7%	16.4%	46.6%	13.5%	0.8%	3388
Montería	27.0%	16.3%	40.9%	14.9%	0.9%	3981
Mosquera	22.6%	11.8%	54.4%	10.8%	0.5%	1037
Nariño	27.0%	15.5%	43.4%	12.8%	1.3%	5979
Neiva	27.1%	13.4%	46.7%	11.8%	0.9%	3004
Norte de Santander	27.9%	15.4%	43.4%	12.5%	0.8%	4838
Palmira	24.6%	14.5%	46.2%	13.5%	1.1%	2248
Pasto	26.3%	12.6%	49.4%	10.8%	1.0%	3679
Pereira	26.0%	13.4%	47.2%	12.4%	1.0%	3671
Piedecuesta	24.5%	12.5%	49.1%	13.4%	0.5%	1187
Pitalito	26.9%	15.5%	45.2%	12.0%	0.4%	1112
Popayán	25.1%	13.0%	50.2%	11.0%	0.6%	2345
Putumayo	27.4%	15.5%	42.5%	13.1%	1.5%	2502
Quibdó	26.1%	19.1%	34.2%	18.7%	1.9%	1233
Quindío	25.1%	15.3%	43.2%	15.5%	0.9%	2071
Riohacha	25.5%	17.6%	40.4%	15.9%	0.5%	1323
Rionegro	20.9%	16.7%	49.5%	11.8%	1.0%	1074
Risaralda	28.9%	15.0%	40.9%	14.5%	0.7%	1908
Sabaneta	17.3%	14.5%	50.1%	11.6%	6.5%	525
Sahagún	27.7%	18.4%	38.1%	15.1%	0.7%	1089
San Andrés	28.7%	15.8%	37.4%	15.6%	2.4%	449
Santa Marta	23.9%	18.9%	40.8%	15.1%	1.4%	4139
Santander	26.9%	14.4%	45.5%	12.6%	0.5%	6241

Continúa en la siguiente página

ETC/País	A	B	C	D	Omisión y multimarca	N° estudiantes
Sincelejo	29.9%	17.1%	39.0%	13.2%	0.8%	2462
Soacha	24.3%	14.0%	48.0%	12.6%	1.1%	4523
Sogamoso	24.2%	12.6%	50.7%	10.7%	1.9%	1361
Soledad	25.6%	16.8%	43.4%	13.4%	0.8%	3637
Sucre	29.7%	18.9%	33.3%	17.1%	1.0%	5370
Tolima	28.0%	16.7%	39.1%	14.8%	1.5%	6918
Tuluá	25.5%	14.4%	45.9%	13.7%	0.4%	1849
Tumaco	31.6%	19.1%	28.8%	19.3%	1.2%	1327
Tunja	21.6%	11.2%	56.6%	9.1%	1.5%	1487
Turbo	29.6%	18.3%	30.5%	19.6%	1.9%	999
Uribe	22.6%	17.5%	38.4%	20.5%	1.0%	292
Valle del Cauca	25.2%	15.7%	42.4%	14.6%	2.1%	6865
Valledupar	24.7%	15.1%	40.1%	14.8%	5.2%	3940
Vaupés	32.9%	9.9%	44.1%	9.2%	3.9%	152
Vichada	26.4%	20.1%	40.5%	11.9%	1.1%	269
Villavicencio	22.6%	14.1%	51.5%	10.8%	1.0%	3946
Yopal	25.6%	12.4%	52.2%	9.0%	0.6%	1271
Zipaquirá	24.2%	13.8%	52.5%	9.2%	0.3%	1108
Colombia	25.1%	15.1%	45.3%	13.3%	1.3%	366383

*Es posible que los porcentajes mostrados no sumen exactamente 100 debido a aproximaciones decimales.

• **Pregunta 13.**

Una embotelladora llena botellas de agua, de la misma capacidad, con cuatro llaves diferentes. Las siguientes gráficas representan la cantidad de agua (en mL) que vierte cada una de las llaves en un determinado tiempo (en s).

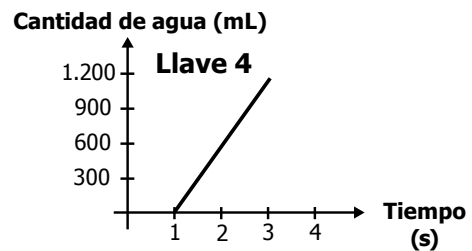
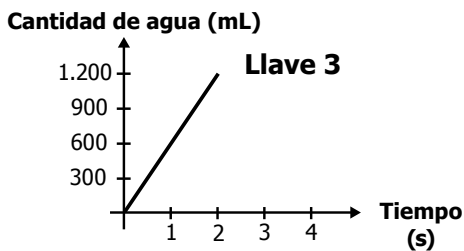
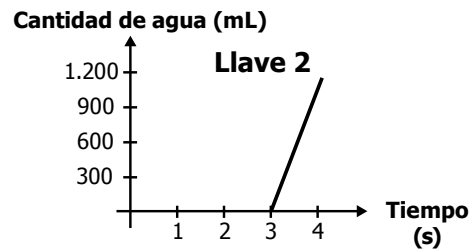
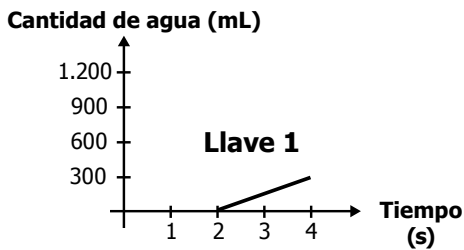

¿Con cuál de las llaves se emplea más tiempo para llenar una botella?

- A. Llave 1.
- B. Llave 2.
- C. Llave 3.
- D. Llave 4.

• **Estructura**

Competencia	Razonamiento
Componente	Numérico - variacional
Afirmación	Interpreta tendencias que se presentan en una situación de variación.
Nivel de desempeño	Satisfactorio
Respuesta Correcta	A

• Resultados a nivel nacional y de Entidad Territorial Certificada (ETC)

ETC/País	A	B	C	D	Omisión y multimarca	N° estudiantes
Amazonas	28.4%	30.7%	22.1%	16.6%	2.2%	589
Antioquia	38.1%	30.3%	17.4%	11.7%	2.5%	16846
Apartadó	35.7%	30.7%	20.8%	12.1%	0.7%	1019
Arauca	42.9%	30.2%	16.3%	9.7%	0.8%	1614
Armenia	45.3%	27.2%	15.6%	11.8%	0.2%	2415
Atlántico	35.5%	29.1%	20.4%	13.9%	1.1%	4578
Barrancabermeja	42.0%	29.2%	16.6%	11.7%	0.6%	1899
Barranquilla	41.2%	29.6%	16.7%	11.5%	1.0%	9988
Bello	41.9%	30.2%	16.3%	10.8%	0.8%	3092
Bogotá, D.C.	49.2%	26.2%	13.9%	9.9%	0.8%	60321
Bolívar	35.0%	29.4%	21.2%	13.3%	1.1%	7070
Boyacá	46.1%	27.4%	16.0%	9.6%	0.8%	7298
Bucaramanga	50.5%	26.8%	13.6%	8.1%	1.1%	4681
Buenaventura	31.9%	31.0%	23.2%	13.0%	1.0%	2198
Buga	43.1%	27.7%	16.7%	10.9%	1.6%	884
Caldas	39.8%	29.9%	18.0%	11.7%	0.7%	4244
Cali	42.1%	29.2%	15.8%	11.6%	1.3%	16005
Caquetá	40.2%	29.9%	17.5%	10.3%	2.1%	1587
Cartagena	40.4%	28.6%	18.0%	11.4%	1.6%	8877
Cartago	39.4%	29.4%	15.4%	14.7%	1.2%	865
Casanare	41.5%	28.0%	17.8%	11.7%	1.0%	2075
Cauca	33.6%	31.5%	20.3%	12.9%	1.7%	7914
Cesar	37.2%	31.4%	18.8%	11.6%	1.1%	5112
Chocó	31.6%	28.4%	22.0%	16.8%	1.2%	1896
Chía	51.6%	27.0%	12.4%	8.7%	0.3%	1289
Ciénaga	34.2%	31.1%	20.0%	13.9%	0.8%	997
Cundinamarca	46.4%	28.1%	14.9%	9.4%	1.3%	13471
Córdoba	33.8%	30.1%	21.0%	14.0%	1.1%	8801
Cúcuta	45.0%	27.8%	16.5%	10.4%	0.3%	6040
Dosquebradas	41.8%	31.1%	14.9%	11.1%	0.9%	1265
Duitama	55.7%	23.8%	12.2%	7.9%	0.5%	1067
Envigado	54.0%	22.8%	13.2%	9.5%	0.4%	1677
Facatativá	46.4%	28.3%	15.3%	8.9%	1.0%	1064
Florencia	42.4%	31.3%	17.0%	9.1%	0.2%	1285
Floridablanca	54.2%	25.1%	12.3%	8.1%	0.3%	2014
Fusagasugá	47.6%	25.4%	16.5%	10.1%	0.4%	1228
Girardot	33.3%	31.2%	18.3%	16.9%	0.3%	901

Continúa en la siguiente página



ETC/País	A	B	C	D	Omisión y multimarca	N° estudiantes
Girón	48.5%	25.7%	15.2%	9.7%	0.8%	945
Guainía	37.2%	37.2%	17.1%	8.5%	0.0%	164
Guaviare	39.8%	30.8%	18.8%	8.3%	2.3%	575
Huila	39.5%	30.2%	18.5%	10.8%	0.9%	5160
Ibagué	43.1%	30.0%	16.2%	9.9%	0.8%	4329
Ipiales	49.1%	28.4%	14.8%	7.2%	0.5%	1011
Itagüí	42.7%	29.2%	14.7%	12.0%	1.3%	1498
Jamundí	37.5%	30.8%	16.8%	13.9%	0.9%	885
La Guajira	34.0%	29.0%	20.9%	14.7%	1.3%	1790
Lorica	31.4%	29.0%	23.1%	16.0%	0.4%	1167
Magangué	33.2%	32.1%	18.4%	11.5%	4.8%	903
Magdalena	33.1%	30.9%	20.5%	14.1%	1.3%	5178
Maicao	34.1%	30.7%	22.1%	12.6%	0.4%	1132
Malambo	35.7%	27.8%	19.6%	15.5%	1.3%	837
Manizales	46.5%	27.8%	14.3%	10.7%	0.7%	2878
Medellín	42.4%	29.0%	16.1%	11.3%	1.3%	16966
Meta	41.1%	29.3%	18.1%	10.7%	0.7%	3388
Montería	38.3%	30.0%	19.2%	11.9%	0.6%	3981
Mosquera	50.0%	26.5%	14.3%	9.0%	0.2%	1037
Nariño	40.0%	29.5%	18.9%	10.6%	1.0%	5979
Neiva	43.2%	27.5%	17.0%	11.6%	0.7%	3004
Norte de Santander	43.6%	29.1%	16.7%	10.0%	0.6%	4838
Palmira	43.4%	30.0%	15.1%	10.6%	0.8%	2248
Pasto	46.3%	28.1%	14.8%	10.1%	0.8%	3679
Pereira	43.3%	27.6%	16.2%	12.1%	0.7%	3671
Piedecuesta	48.4%	26.5%	13.4%	11.5%	0.3%	1187
Pitalito	43.8%	29.7%	16.0%	10.2%	0.4%	1112
Popayán	42.4%	30.3%	16.8%	9.9%	0.6%	2345
Putumayo	40.0%	31.7%	17.7%	9.4%	1.2%	2502
Quibdó	34.6%	27.3%	22.5%	13.7%	1.9%	1233
Quindío	39.4%	30.2%	18.1%	12.0%	0.2%	2071
Riohacha	37.0%	29.6%	19.0%	14.1%	0.3%	1323
Rionegro	48.6%	25.0%	14.9%	10.7%	0.7%	1074
Risaralda	37.8%	32.7%	18.0%	11.1%	0.5%	1908
Sabaneta	45.3%	25.1%	12.2%	10.9%	6.5%	525
Sahagún	34.7%	30.5%	21.3%	13.2%	0.3%	1089
San Andrés	38.5%	30.1%	17.1%	12.2%	2.0%	449
Santa Marta	38.7%	29.7%	18.8%	11.9%	0.9%	4139
Santander	46.6%	28.5%	14.7%	9.8%	0.4%	6241

Continúa en la siguiente página

ETC/País	A	B	C	D	Omisión y multimarca	N° estudiantes
Sincelejo	38.5%	32.1%	18.8%	10.0%	0.6%	2462
Soacha	42.6%	29.8%	16.0%	10.8%	0.8%	4523
Sogamoso	51.3%	25.3%	12.4%	9.0%	2.0%	1361
Soledad	41.2%	27.7%	18.3%	12.2%	0.7%	3637
Sucre	34.6%	30.3%	21.4%	13.1%	0.6%	5370
Tolima	36.3%	31.0%	19.1%	12.4%	1.2%	6918
Tuluá	41.3%	30.1%	16.4%	12.0%	0.2%	1849
Tumaco	33.0%	29.2%	22.4%	14.6%	0.8%	1327
Tunja	53.9%	22.9%	13.0%	8.9%	1.3%	1487
Turbo	29.7%	30.5%	24.9%	13.2%	1.6%	999
Uribe	26.7%	32.5%	22.9%	17.5%	0.3%	292
Valle del Cauca	37.5%	29.5%	18.3%	12.9%	1.8%	6865
Valledupar	35.5%	29.7%	17.9%	11.8%	5.1%	3940
Vaupés	29.6%	31.6%	27.0%	8.6%	3.3%	152
Vichada	39.8%	28.3%	16.7%	15.2%	0.0%	269
Villavicencio	45.4%	28.1%	15.4%	10.4%	0.6%	3946
Yopal	47.6%	26.8%	14.6%	10.3%	0.7%	1271
Zipaquirá	45.3%	28.8%	15.0%	10.8%	0.1%	1108
Colombia	42.2%	28.7%	16.8%	11.2%	1.1%	366383

*Es posible que los porcentajes mostrados no sumen exactamente 100 debido a aproximaciones decimales.

• **Pregunta 14.**

Para facturar el consumo de energía de una vivienda en la que no se pudo realizar la lectura del contador, la empresa de energía promedió el consumo de los últimos 6 meses.

En la gráfica aparece el consumo, en Kwh, de esta vivienda en esos meses.

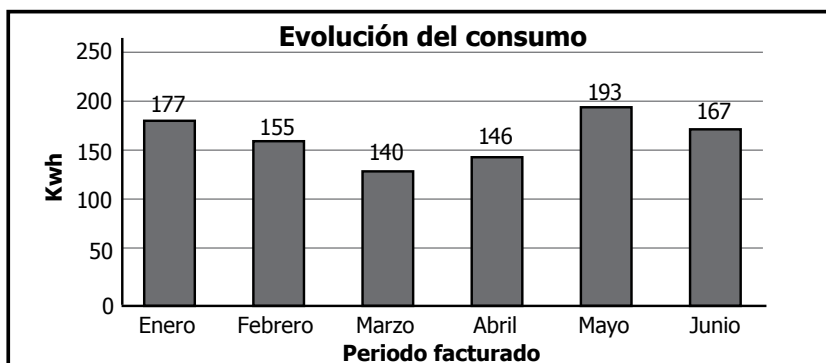

Gráfica

Con este procedimiento, ¿cuántos Kwh facturó la empresa de energía en esta vivienda?

- A. 163
- B. 166
- C. 177
- D. 193

• **Estructura**

Competencia	Resolución
Componente	Aleatorio
Afirmación	Resolver problemas que requieran el uso e interpretación de medidas de tendencia central para analizar el comportamiento de un conjunto de datos.
Nivel de desempeño	Avanzado
Respuesta Correcta	A

• Resultados a nivel nacional y de Entidad Territorial Certificada (ETC)

ETC/País	A	B	C	D	Omisión y multimarca	N° estudiantes
Amazonas	11.2%	12.7%	14.4%	59.3%	2.4%	589
Antioquia	16.2%	15.7%	15.5%	49.7%	2.8%	16846
Apartadó	17.5%	15.7%	19.6%	46.1%	1.1%	1019
Arauca	17.1%	16.5%	16.1%	49.4%	0.9%	1614
Armenia	19.4%	17.9%	19.3%	42.9%	0.6%	2415
Atlántico	17.0%	14.7%	16.1%	50.6%	1.6%	4578
Barrancabermeja	19.5%	17.0%	16.7%	45.7%	1.1%	1899
Barranquilla	19.8%	16.1%	14.9%	47.6%	1.6%	9988
Bello	19.0%	16.6%	15.9%	47.4%	1.0%	3092
Bogotá, D.C.	24.8%	16.6%	14.2%	43.3%	1.2%	60321
Bolívar	14.7%	14.2%	17.1%	52.3%	1.7%	7070
Boyacá	22.0%	16.1%	14.3%	46.7%	0.9%	7298
Bucaramanga	25.8%	15.3%	13.6%	43.9%	1.5%	4681
Buenaventura	17.4%	15.7%	14.7%	50.6%	1.5%	2198
Buga	22.5%	17.3%	14.5%	43.9%	1.8%	884
Caldas	17.9%	15.7%	15.7%	49.7%	0.9%	4244
Cali	20.4%	16.5%	14.5%	46.7%	1.9%	16005
Caquetá	17.3%	16.4%	16.3%	47.5%	2.6%	1587
Cartagena	19.8%	15.5%	16.1%	46.2%	2.3%	8877
Cartago	17.6%	14.8%	16.2%	49.9%	1.5%	865
Casanare	16.9%	16.4%	15.0%	50.5%	1.2%	2075
Cauca	14.9%	13.1%	14.8%	55.1%	2.1%	7914
Cesar	16.9%	15.6%	15.6%	50.7%	1.0%	5112
Chocó	13.8%	15.6%	17.1%	52.2%	1.3%	1896
Chía	25.2%	19.5%	14.4%	39.9%	1.0%	1289
Ciénaga	13.1%	16.4%	18.4%	50.3%	1.8%	997
Cundinamarca	21.5%	15.6%	14.5%	46.8%	1.7%	13471
Córdoba	13.5%	14.1%	17.0%	54.0%	1.3%	8801
Cúcuta	22.3%	14.8%	15.8%	46.5%	0.7%	6040
Dosquebradas	20.9%	18.3%	15.3%	44.0%	1.5%	1265
Duitama	35.4%	17.7%	13.8%	32.5%	0.6%	1067
Envigado	28.4%	18.1%	14.5%	38.5%	0.5%	1677
Facatativá	22.9%	19.6%	12.8%	43.7%	0.9%	1064
Florencia	24.4%	14.6%	11.8%	49.1%	0.2%	1285
Floridablanca	26.7%	15.3%	15.0%	42.5%	0.5%	2014
Fusagasugá	23.1%	16.9%	13.4%	46.0%	0.6%	1228
Girardot	17.6%	15.8%	18.1%	47.7%	0.8%	901

Continúa en la siguiente página



ETC/País	A	B	C	D	Omisión y multimarca	N° estudiantes
Girón	22.6%	13.5%	13.8%	48.8%	1.3%	945
Guainía	18.9%	14.6%	14.0%	52.4%	0.0%	164
Guaviare	14.4%	16.3%	17.0%	49.4%	2.8%	575
Huila	17.8%	14.7%	14.6%	51.8%	1.2%	5160
Ibagué	21.7%	15.0%	15.2%	46.8%	1.3%	4329
Ipiales	26.5%	14.8%	13.6%	43.8%	1.3%	1011
Itagüí	20.2%	20.4%	18.9%	38.9%	1.6%	1498
Jamundí	16.6%	16.3%	14.1%	52.8%	0.2%	885
La Guajira	17.8%	13.6%	15.6%	51.4%	1.5%	1790
Lorica	10.6%	14.2%	21.3%	53.1%	0.7%	1167
Magangué	14.1%	12.7%	16.4%	51.7%	5.1%	903
Magdalena	14.3%	15.4%	16.8%	51.6%	1.9%	5178
Maicao	11.7%	16.0%	16.1%	55.7%	0.5%	1132
Malambo	19.4%	15.4%	13.7%	50.2%	1.3%	837
Manizales	19.0%	17.1%	16.0%	47.3%	0.7%	2878
Medellín	19.2%	17.3%	17.1%	44.7%	1.7%	16966
Meta	17.9%	15.6%	14.6%	50.9%	1.0%	3388
Montería	17.4%	15.3%	14.7%	51.4%	1.2%	3981
Mosquera	24.4%	17.3%	12.7%	45.1%	0.5%	1037
Nariño	19.8%	12.7%	12.8%	53.2%	1.5%	5979
Neiva	21.8%	14.7%	13.8%	48.8%	0.8%	3004
Norte de Santander	18.3%	14.3%	14.1%	52.5%	0.8%	4838
Palmira	22.0%	14.9%	14.7%	47.1%	1.3%	2248
Pasto	22.6%	15.2%	13.4%	47.6%	1.3%	3679
Pereira	22.8%	16.8%	15.9%	43.6%	1.0%	3671
Piedecuesta	21.3%	16.1%	15.4%	46.4%	0.8%	1187
Pitalito	17.4%	17.2%	16.0%	48.7%	0.7%	1112
Popayán	23.2%	14.6%	14.7%	45.9%	1.7%	2345
Putumayo	17.0%	15.1%	15.2%	50.9%	1.7%	2502
Quibdó	15.2%	16.2%	16.6%	50.3%	1.6%	1233
Quindío	15.8%	16.5%	16.3%	50.7%	0.7%	2071
Riohacha	15.9%	15.0%	14.7%	53.7%	0.7%	1323
Rionegro	22.0%	17.2%	14.2%	45.8%	0.7%	1074
Risaralda	15.6%	16.1%	16.1%	51.5%	0.6%	1908
Sabaneta	25.9%	13.3%	14.5%	40.0%	6.3%	525
Sahagún	14.3%	12.8%	15.2%	57.1%	0.6%	1089
San Andrés	14.5%	18.3%	22.0%	42.5%	2.7%	449
Santa Marta	16.5%	17.3%	17.9%	46.9%	1.4%	4139
Santander	23.0%	14.5%	14.5%	47.5%	0.6%	6241

Continúa en la siguiente página

ETC/País	A	B	C	D	Omisión y multimarca	N° estudiantes
Sincelejo	19.2%	12.8%	14.3%	52.7%	1.1%	2462
Soacha	20.0%	16.1%	15.5%	47.4%	1.0%	4523
Sogamoso	26.5%	16.2%	14.2%	40.8%	2.4%	1361
Soledad	20.5%	16.5%	16.6%	45.4%	0.9%	3637
Sucre	13.2%	13.4%	15.7%	56.7%	1.0%	5370
Tolima	15.9%	15.4%	15.5%	51.6%	1.6%	6918
Tuluá	19.1%	17.7%	15.1%	47.2%	0.9%	1849
Tumaco	13.4%	13.5%	17.4%	54.6%	1.1%	1327
Tunja	30.4%	17.4%	13.4%	37.3%	1.5%	1487
Turbo	10.0%	13.4%	18.3%	56.1%	2.2%	999
Uribe	9.2%	12.0%	13.7%	64.0%	1.0%	292
Valle del Cauca	17.6%	15.8%	15.0%	49.2%	2.4%	6865
Valledupar	17.0%	14.4%	15.5%	47.5%	5.8%	3940
Vaupés	5.9%	6.6%	8.6%	75.0%	3.9%	152
Vichada	13.0%	15.6%	13.8%	56.5%	1.1%	269
Villavicencio	23.4%	17.3%	15.0%	43.4%	0.9%	3946
Yopal	26.4%	15.3%	15.9%	41.3%	1.2%	1271
Zipaquirá	27.3%	16.8%	13.4%	42.0%	0.5%	1108
Colombia	19.9%	15.7%	15.2%	47.6%	1.5%	366383

*Es posible que los porcentajes mostrados no sumen exactamente 100 debido a aproximaciones decimales.

• **Pregunta 15.**

La tabla representa los resultados de las entrevistas realizadas por el departamento de recursos humanos de una empresa a 6 aspirantes a un cargo.

Aspirante	Aspiración salarial	Estudia actualmente	Tiene moto
M	\$600.000	Sí	Sí
N	\$500.000	No	No
P	\$700.000	Sí	No
Q	\$550.000	No	Sí
R	\$500.000	No	Sí
S	\$800.000	Sí	Sí

Tabla

Si a la empresa le interesa contratar un trabajador que no estudie actualmente, tenga moto y una aspiración salarial que no supere los \$600.000, es correcto afirmar que la empresa

- A. puede seleccionarlo, porque cualquiera de los seis aspirantes cumple con los requisitos exigidos.
- B. puede seleccionarlo, porque al menos un aspirante reúne los requisitos exigidos.
- C. no puede seleccionarlo, porque los aspirantes que tienen moto, estudian.
- D. no puede seleccionarlo, porque los aspirantes que tienen menor aspiración salarial no tienen moto.

• **Estructura**

Competencia	Comunicación
Componente	Aleatorio
Afirmación	Reconocer la posibilidad o la imposibilidad de ocurrencia de un evento a partir de una información dada o de un fenómeno.
Nivel de desempeño	Satisfactorio
Respuesta Correcta	B

• Resultados a nivel nacional y de Entidad Territorial Certificada (ETC)

ETC/País	A	B	C	D	Omisión y multimarca	N° estudiantes
Amazonas	25.1%	49.4%	12.2%	10.2%	3.1%	589
Antioquia	14.6%	60.4%	12.9%	9.3%	2.7%	16846
Apartadó	17.6%	55.3%	16.4%	9.5%	1.2%	1019
Arauca	14.9%	62.8%	13.1%	8.2%	1.0%	1614
Armenia	12.3%	66.3%	13.4%	7.6%	0.5%	2415
Atlántico	18.7%	53.0%	15.6%	11.0%	1.8%	4578
Barrancabermeja	16.0%	62.6%	11.7%	8.8%	0.9%	1899
Barranquilla	14.1%	63.8%	12.5%	8.4%	1.3%	9988
Bello	12.3%	66.9%	11.7%	8.1%	1.1%	3092
Bogotá, D.C.	9.5%	73.5%	9.8%	6.2%	1.0%	60321
Bolívar	22.4%	46.6%	17.5%	11.9%	1.6%	7070
Boyacá	12.1%	65.9%	12.9%	7.9%	1.1%	7298
Bucaramanga	10.3%	73.8%	9.1%	5.6%	1.3%	4681
Buenaventura	21.1%	53.1%	13.8%	10.1%	1.9%	2198
Buga	10.5%	70.6%	9.8%	7.4%	1.7%	884
Caldas	14.0%	63.4%	12.3%	9.3%	0.9%	4244
Calí	11.8%	67.4%	11.8%	7.3%	1.6%	16005
Caquetá	17.1%	57.0%	14.6%	9.1%	2.3%	1587
Cartagena	17.5%	56.3%	13.7%	10.3%	2.1%	8877
Cartago	12.7%	66.1%	10.9%	9.4%	0.9%	865
Casanare	14.3%	62.4%	12.7%	9.3%	1.4%	2075
Cauca	18.2%	54.6%	14.1%	11.0%	2.1%	7914
Cesar	18.9%	54.2%	14.5%	11.4%	1.0%	5112
Chocó	23.8%	45.5%	16.6%	12.3%	1.8%	1896
Chía	7.6%	75.6%	10.3%	5.9%	0.5%	1289
Ciénaga	20.5%	51.2%	15.9%	11.4%	1.0%	997
Cundinamarca	11.9%	68.6%	10.8%	7.2%	1.5%	13471
Córdoba	21.4%	50.8%	14.9%	11.7%	1.2%	8801
Cúcuta	13.3%	64.6%	13.0%	8.5%	0.5%	6040
Dosquebradas	10.4%	69.3%	10.8%	8.2%	1.3%	1265
Duitama	8.4%	76.8%	9.7%	4.4%	0.7%	1067
Envigado	9.5%	72.5%	10.7%	6.6%	0.7%	1677
Facatativá	10.4%	71.6%	11.1%	5.9%	0.9%	1064
Florencia	12.5%	67.5%	11.8%	8.0%	0.2%	1285
Floridablanca	9.9%	73.9%	9.6%	6.0%	0.6%	2014
Fusagasugá	10.6%	71.1%	11.0%	7.1%	0.2%	1228
Girardot	18.0%	57.3%	13.3%	10.7%	0.8%	901

Continúa en la siguiente página



ETC/País	A	B	C	D	Omisión y multimarca	N° estudiantes
Girón	11.2%	71.2%	11.1%	5.5%	1.0%	945
Guainía	19.5%	58.5%	11.6%	7.3%	3.0%	164
Guaviare	15.3%	55.3%	15.5%	11.0%	3.0%	575
Huila	15.6%	62.7%	12.6%	8.1%	1.0%	5160
Ibagué	11.7%	69.4%	11.1%	6.9%	0.9%	4329
Ipsiales	11.1%	69.4%	10.4%	8.4%	0.7%	1011
Itagüí	14.5%	56.3%	15.8%	11.5%	1.9%	1498
Jamundí	14.5%	63.6%	12.9%	8.2%	0.8%	885
La Guajira	20.2%	50.9%	16.1%	11.0%	1.7%	1790
Lorica	23.1%	45.5%	16.3%	14.5%	0.6%	1167
Magangué	19.3%	48.7%	14.5%	12.4%	5.1%	903
Magdalena	20.9%	46.9%	17.1%	13.4%	1.7%	5178
Maicao	23.7%	48.9%	15.9%	10.9%	0.6%	1132
Malambo	19.1%	58.2%	13.3%	7.6%	1.8%	837
Manizales	12.0%	68.6%	12.0%	6.6%	0.8%	2878
Medellín	12.9%	64.5%	12.5%	8.5%	1.6%	16966
Meta	15.0%	61.8%	12.8%	9.5%	0.9%	3388
Montería	18.8%	58.0%	13.7%	8.5%	1.0%	3981
Mosquera	10.7%	75.7%	9.0%	4.3%	0.3%	1037
Nariño	13.4%	64.3%	12.2%	8.9%	1.2%	5979
Neiva	13.0%	67.5%	12.1%	6.6%	0.8%	3004
Norte de Santander	14.0%	63.6%	13.4%	8.3%	0.7%	4838
Palmira	12.8%	68.5%	11.3%	6.5%	1.0%	2248
Pasto	10.5%	70.8%	10.5%	7.1%	1.2%	3679
Pereira	11.2%	68.5%	11.9%	7.6%	0.9%	3671
Piedecuesta	11.6%	68.8%	12.5%	6.7%	0.3%	1187
Pitalito	11.2%	66.9%	12.7%	8.7%	0.4%	1112
Popayán	9.6%	71.7%	10.4%	7.5%	0.7%	2345
Putumayo	14.9%	59.2%	15.0%	9.6%	1.3%	2502
Quibdó	19.5%	50.6%	16.8%	11.0%	2.0%	1233
Quindío	13.2%	63.7%	14.0%	8.6%	0.5%	2071
Riohacha	18.4%	56.5%	13.4%	11.0%	0.8%	1323
Rionegro	10.7%	69.6%	11.8%	6.8%	1.1%	1074
Risaralda	13.0%	62.7%	14.8%	8.6%	0.8%	1908
Sabaneta	9.5%	70.9%	7.6%	5.5%	6.5%	525
Sahagún	16.8%	57.0%	14.5%	11.2%	0.5%	1089
San Andrés	17.6%	50.1%	20.7%	9.1%	2.4%	449
Santa Marta	16.2%	55.9%	15.9%	10.2%	1.8%	4139
Santander	12.7%	67.0%	11.7%	8.0%	0.5%	6241

Continúa en la siguiente página

ETC/País	A	B	C	D	Omisión y multimarca	N° estudiantes
Sincelejo	16.7%	59.2%	13.8%	9.3%	1.0%	2462
Soacha	12.6%	67.3%	12.6%	6.5%	0.9%	4523
Sogamoso	7.8%	73.8%	11.0%	5.4%	2.0%	1361
Soledad	16.1%	60.6%	12.2%	10.1%	1.0%	3637
Sucre	20.4%	50.6%	15.8%	12.0%	1.1%	5370
Tolima	16.3%	58.6%	13.8%	9.8%	1.5%	6918
Tuluá	14.2%	66.4%	11.3%	8.0%	0.2%	1849
Tumaco	21.2%	49.7%	16.1%	11.6%	1.4%	1327
Tunja	8.9%	75.5%	8.7%	5.4%	1.4%	1487
Turbo	21.0%	46.9%	18.2%	11.7%	2.1%	999
Uribe	30.1%	41.4%	17.8%	9.9%	0.7%	292
Valle del Cauca	14.7%	61.8%	12.6%	8.8%	2.0%	6865
Valledupar	15.9%	56.6%	13.5%	8.7%	5.3%	3940
Vaupés	25.7%	51.3%	9.9%	9.2%	3.9%	152
Vichada	15.6%	60.6%	12.6%	11.2%	0.0%	269
Villavicencio	12.0%	67.7%	12.1%	7.4%	0.8%	3946
Yopal	9.5%	72.3%	11.2%	6.2%	0.8%	1271
Zipaquirá	10.7%	72.8%	10.1%	6.2%	0.1%	1108
Colombia	13.9%	63.8%	12.5%	8.4%	1.3%	366383

*Es posible que los porcentajes mostrados no sumen exactamente 100 debido a aproximaciones decimales.

• **Pregunta 16.**

La figura presenta un trapecio dibujado sobre una cuadrícula.

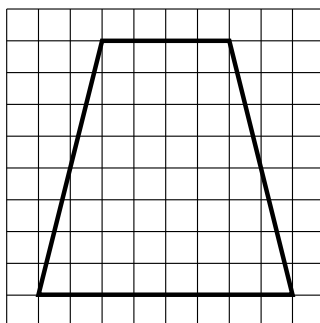

Figura

El plano cartesiano que permite obtener la información precisa referente a la posición de los vértices y a las medidas de los lados del trapecio es

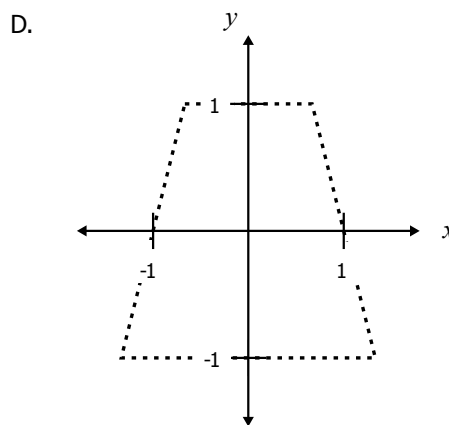
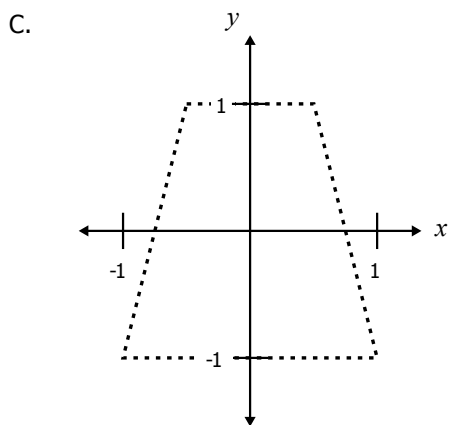
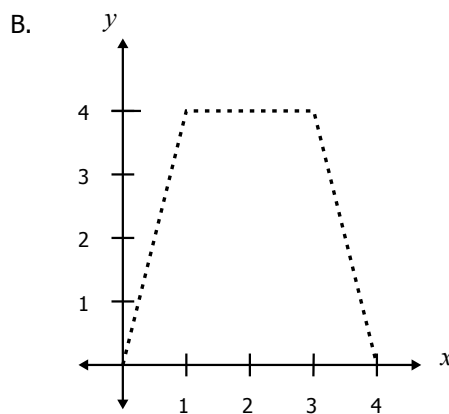
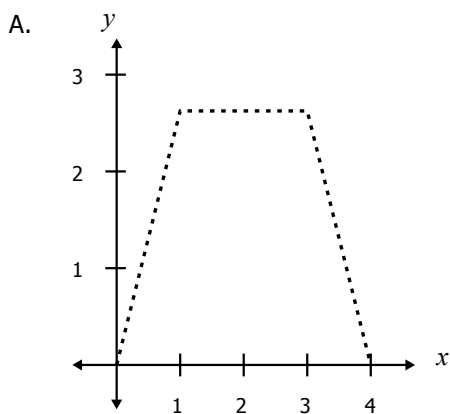

• Estructura

Competencia	Comunicación
Componente	Espacial - métrico
Afirmación	Usar sistemas de referencia para localizar o describir posición de objetos y figuras.
Nivel de desempeño	Avanzado
Respuesta Correcta	B

• Resultados a nivel nacional y de Entidad Territorial Certificada (ETC)

ETC/País	A	B	C	D	Omisión y multimarca	N° estudiantes
Amazonas	11.4%	38.0%	30.7%	16.5%	3.4%	589
Antioquia	12.5%	38.8%	30.5%	15.3%	2.8%	16846
Apartadó	13.9%	39.2%	29.9%	15.6%	1.4%	1019
Arauca	11.5%	42.9%	28.3%	16.3%	1.1%	1614
Armenia	13.3%	40.3%	29.3%	16.3%	0.8%	2415
Atlántico	15.6%	37.7%	29.7%	15.0%	2.0%	4578
Barrancabermeja	11.8%	41.7%	27.9%	17.5%	1.0%	1899
Barranquilla	13.3%	40.4%	29.0%	15.9%	1.4%	9988
Bello	10.6%	40.4%	30.2%	17.9%	0.9%	3092
Bogotá, D.C.	9.6%	46.0%	27.0%	16.3%	1.1%	60321
Bolívar	14.8%	39.6%	30.2%	13.6%	1.8%	7070
Boyacá	11.2%	46.0%	27.8%	14.0%	1.0%	7298
Bucaramanga	10.7%	48.3%	23.7%	15.9%	1.5%	4681
Buenaventura	14.4%	41.3%	28.8%	13.6%	1.9%	2198
Buga	11.7%	38.3%	29.3%	18.7%	2.0%	884
Caldas	12.2%	41.9%	30.2%	14.8%	0.9%	4244
Cali	10.8%	43.2%	27.8%	16.5%	1.7%	16005
Caquetá	13.2%	42.3%	28.0%	14.1%	2.5%	1587
Cartagena	14.1%	39.7%	29.0%	15.1%	2.2%	8877
Cartago	10.2%	39.2%	28.3%	21.2%	1.2%	865
Casanare	11.0%	44.5%	26.7%	16.3%	1.3%	2075
Cauca	12.9%	42.3%	28.4%	14.3%	2.1%	7914
Cesar	14.1%	41.7%	29.0%	13.9%	1.2%	5112
Chocó	18.1%	36.5%	32.1%	11.2%	2.1%	1896
Chía	8.1%	49.4%	26.2%	15.7%	0.6%	1289

Continúa en la siguiente página



ETC/País	A	B	C	D	Omisión y multimarca	N° estudiantes
Ciénaga	18.3%	35.3%	29.9%	15.0%	1.5%	997
Cundinamarca	10.1%	45.0%	28.1%	15.2%	1.5%	13471
Córdoba	15.5%	39.4%	30.2%	13.4%	1.4%	8801
Cúcuta	11.4%	44.1%	27.9%	16.2%	0.4%	6040
Dosquebradas	11.1%	42.7%	27.7%	17.5%	1.0%	1265
Duitama	7.3%	57.8%	20.9%	13.2%	0.7%	1067
Envigado	8.4%	45.9%	25.4%	19.7%	0.6%	1677
Facatativá	9.4%	44.5%	30.1%	15.1%	0.8%	1064
Florencia	10.7%	47.2%	25.8%	16.1%	0.2%	1285
Floridablanca	10.3%	49.6%	24.8%	14.8%	0.5%	2014
Fusagasugá	10.0%	45.8%	27.2%	16.3%	0.7%	1228
Girardot	11.9%	40.4%	28.2%	18.2%	1.3%	901
Girón	11.2%	43.1%	27.6%	16.9%	1.2%	945
Guainía	8.5%	41.5%	24.4%	23.8%	1.8%	164
Guaviare	11.3%	40.7%	31.3%	13.9%	2.8%	575
Huila	11.8%	43.7%	28.1%	15.3%	1.1%	5160
Ibagué	10.9%	42.8%	28.4%	16.9%	1.1%	4329
Ipiales	10.7%	51.5%	21.5%	15.4%	0.9%	1011
Itagüí	13.4%	37.2%	29.8%	17.8%	1.9%	1498
Jamundí	12.2%	43.7%	26.2%	17.1%	0.8%	885
La Guajira	16.0%	38.5%	29.7%	14.0%	1.8%	1790
Lorica	16.8%	39.3%	31.3%	11.7%	0.9%	1167
Magangué	14.2%	35.9%	28.1%	16.6%	5.2%	903
Magdalena	16.8%	37.2%	31.1%	13.1%	1.9%	5178
Maicao	15.5%	37.6%	31.5%	14.4%	1.0%	1132
Malambo	11.6%	46.0%	29.5%	11.4%	1.6%	837
Manizales	12.0%	42.5%	27.6%	17.1%	0.8%	2878
Medellín	11.5%	40.1%	29.2%	17.6%	1.7%	16966
Meta	12.3%	40.9%	29.0%	16.9%	0.9%	3388
Montería	13.6%	39.5%	30.5%	15.3%	1.1%	3981
Mosquera	9.3%	43.9%	31.0%	15.4%	0.5%	1037
Nariño	11.2%	48.7%	25.5%	13.5%	1.2%	5979
Neiva	11.4%	45.2%	25.3%	17.2%	0.8%	3004
Norte de Santander	12.1%	43.0%	29.4%	14.7%	0.8%	4838
Palmira	10.1%	46.6%	25.2%	17.0%	1.1%	2248
Pasto	9.8%	49.7%	25.5%	14.0%	1.0%	3679
Pereira	10.9%	44.9%	26.0%	17.4%	0.8%	3671
Piedecuesta	11.4%	43.4%	26.7%	18.1%	0.4%	1187
Pitalito	9.4%	43.2%	28.1%	18.6%	0.6%	1112

Continúa en la siguiente página

ETC/País	A	B	C	D	Omisión y multimarca	N° estudiantes
Popayán	9.8%	48.2%	24.2%	16.9%	0.9%	2345
Putumayo	11.4%	47.2%	26.0%	14.1%	1.4%	2502
Quibdó	15.2%	33.1%	34.5%	14.8%	2.3%	1233
Quindío	12.7%	39.1%	32.2%	15.3%	0.7%	2071
Riohacha	15.5%	36.4%	33.4%	13.8%	0.9%	1323
Rionegro	10.2%	43.2%	27.5%	18.2%	0.8%	1074
Risaralda	13.0%	40.5%	30.5%	15.4%	0.7%	1908
Sabaneta	6.7%	44.6%	23.4%	18.7%	6.7%	525
Sahagún	14.0%	39.3%	30.4%	15.7%	0.6%	1089
San Andrés	15.6%	35.2%	33.0%	13.1%	3.1%	449
Santa Marta	14.9%	36.4%	30.5%	16.2%	2.0%	4139
Santander	10.8%	47.4%	26.6%	14.6%	0.6%	6241
Sincedejo	12.3%	44.5%	28.8%	13.3%	1.0%	2462
Soacha	11.5%	41.7%	29.4%	16.4%	1.0%	4523
Sogamoso	7.9%	49.6%	25.0%	15.6%	2.0%	1361
Soledad	13.1%	42.2%	28.8%	15.0%	0.9%	3637
Sucre	15.1%	37.6%	31.2%	15.0%	1.1%	5370
Tolima	12.4%	41.1%	29.5%	15.3%	1.6%	6918
Tuluá	11.0%	38.9%	32.1%	17.3%	0.8%	1849
Tumaco	16.4%	37.8%	32.2%	12.1%	1.6%	1327
Tunja	8.6%	49.2%	24.3%	16.3%	1.7%	1487
Turbo	17.3%	35.4%	30.8%	14.0%	2.4%	999
Uribe	13.0%	39.4%	30.8%	15.8%	1.0%	292
Valle del Cauca	12.3%	40.3%	29.3%	15.8%	2.3%	6865
Valledupar	13.2%	36.4%	30.5%	14.1%	5.9%	3940
Vaupés	6.6%	44.7%	25.0%	17.8%	5.9%	152
Vichada	14.9%	43.9%	27.9%	13.0%	0.4%	269
Villavicencio	11.7%	42.2%	28.6%	16.5%	0.9%	3946
Yopal	8.9%	46.3%	26.4%	17.5%	0.9%	1271
Zipaquirá	9.9%	47.9%	26.1%	15.9%	0.2%	1108
Colombia	11.9%	42.7%	28.4%	15.6%	1.4%	366383

*Es posible que los porcentajes mostrados no sumen exactamente 100 debido a aproximaciones decimales.

• **Pregunta 17.**

Un estudio realizado en el año 2010 por *Analitika Research & Marketing*, presentó las siguientes gráficas, relacionadas con el tiempo de conexión de los usuarios, de tres redes sociales.

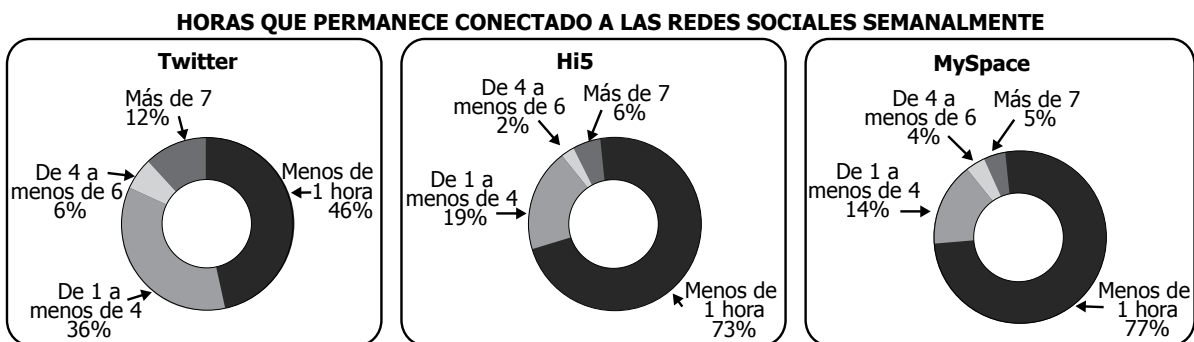

Tomado de: *Analitika Research y Marketing* (2010).

De acuerdo con la información, al escoger una de estas redes es más frecuente que los usuarios de esta red se conecten semanalmente

- A. menos de 1 hora.
- B. de 1 hora a menos de 4 horas.
- C. de 4 horas a menos de 6 horas.
- D. más de 7 horas.

• **Estructura**

Competencia	Resolución
Componente	Aleatorio
Afirmación	Resolver problemas que requieran el uso e interpretación de medidas de tendencia central para analizar el comportamiento de un conjunto de datos.
Nivel de desempeño	Satisfactorio
Respuesta Correcta	A

• Resultados a nivel nacional y de Entidad Territorial Certificada (ETC)

ETC/País	A	B	C	D	Omisión y multimarca	N° estudiantes
Amazonas	30.7%	22.6%	20.9%	21.6%	4.2%	589
Antioquia	40.5%	21.8%	18.7%	16.1%	3.0%	16846
Apartadó	37.0%	23.4%	21.1%	16.4%	2.2%	1019
Arauca	42.1%	20.2%	20.5%	16.1%	1.1%	1614
Armenia	46.1%	20.1%	18.0%	14.8%	1.0%	2415
Atlántico	36.9%	22.2%	19.5%	19.5%	1.9%	4578
Barrancabermeja	46.9%	19.4%	17.1%	15.8%	0.8%	1899
Barranquilla	47.9%	19.3%	17.2%	14.2%	1.5%	9988
Bello	50.4%	18.5%	16.6%	13.5%	1.1%	3092
Bogotá, D.C.	55.1%	17.9%	14.8%	10.9%	1.3%	60321
Bolívar	33.5%	22.4%	22.9%	19.4%	1.8%	7070
Boyacá	45.3%	21.5%	17.9%	13.9%	1.4%	7298
Bucaramanga	56.7%	16.7%	14.4%	10.6%	1.5%	4681
Buenaventura	35.9%	23.4%	18.8%	19.7%	2.1%	2198
Buga	47.1%	19.7%	16.9%	14.0%	2.4%	884
Caldas	42.8%	21.1%	18.5%	16.6%	1.0%	4244
Cali	47.5%	19.5%	16.8%	14.3%	2.0%	16005
Caquetá	33.3%	25.0%	21.0%	18.1%	2.6%	1587
Cartagena	43.0%	20.7%	18.3%	15.8%	2.2%	8877
Cartago	44.9%	20.6%	17.8%	15.4%	1.4%	865
Casanare	42.4%	23.1%	19.9%	13.1%	1.5%	2075
Cauca	35.7%	21.9%	19.9%	20.0%	2.5%	7914
Cesar	37.1%	23.0%	20.8%	17.6%	1.4%	5112
Chocó	28.7%	22.5%	21.2%	25.6%	2.0%	1896
Chía	58.1%	16.1%	15.6%	9.7%	0.5%	1289
Ciénaga	36.6%	23.5%	20.0%	18.4%	1.6%	997
Cundinamarca	48.7%	19.5%	16.9%	13.1%	1.8%	13471
Córdoba	34.3%	23.2%	21.7%	19.5%	1.3%	8801
Cúcuta	48.0%	20.7%	17.2%	13.4%	0.7%	6040
Dosquebradas	50.0%	19.1%	16.2%	13.4%	1.3%	1265
Duitama	60.9%	16.8%	12.6%	9.0%	0.7%	1067
Envigado	58.9%	16.6%	13.5%	10.1%	0.8%	1677
Facatativá	53.0%	18.1%	13.8%	13.3%	1.7%	1064
Florencia	42.7%	22.2%	18.8%	16.2%	0.2%	1285
Floridablanca	55.6%	18.6%	14.3%	10.8%	0.8%	2014
Fusagasugá	52.4%	18.6%	16.3%	11.9%	0.7%	1228
Girardot	42.3%	20.6%	20.1%	15.9%	1.1%	901

Continúa en la siguiente página



ETC/País	A	B	C	D	Omisión y multimarca	N° estudiantes
Girón	54.8%	16.8%	14.9%	12.0%	1.5%	945
Guainía	29.3%	26.2%	19.5%	22.6%	2.4%	164
Guaviare	33.6%	24.3%	20.7%	18.6%	2.8%	575
Huila	42.0%	20.6%	19.8%	16.4%	1.2%	5160
Ibagué	50.0%	19.2%	16.3%	13.2%	1.2%	4329
Ipiales	48.8%	20.0%	16.4%	13.9%	0.9%	1011
Itagüí	43.3%	19.8%	16.7%	18.4%	1.8%	1498
Jamundí	46.7%	19.2%	19.4%	13.0%	1.7%	885
La Guajira	34.5%	23.7%	20.7%	19.5%	1.6%	1790
Lorica	29.0%	24.3%	23.0%	22.7%	1.0%	1167
Magangué	37.8%	20.6%	17.5%	19.2%	5.0%	903
Magdalena	32.2%	22.8%	21.8%	21.2%	2.0%	5178
Maicao	33.8%	23.7%	21.1%	20.5%	0.9%	1132
Malambo	45.4%	18.9%	17.3%	17.0%	1.4%	837
Manizales	47.9%	19.7%	18.7%	12.7%	0.9%	2878
Medellín	46.3%	19.8%	17.5%	14.5%	1.9%	16966
Meta	43.0%	22.0%	19.7%	14.1%	1.2%	3388
Montería	41.4%	20.4%	20.0%	17.0%	1.2%	3981
Mosquera	55.7%	17.4%	16.6%	9.5%	0.8%	1037
Nariño	41.3%	21.1%	18.9%	16.9%	1.8%	5979
Neiva	51.3%	18.6%	16.5%	12.5%	1.2%	3004
Norte de Santander	43.7%	21.4%	18.0%	15.9%	1.0%	4838
Palmira	51.8%	18.3%	15.2%	13.5%	1.2%	2248
Pasto	50.3%	19.1%	16.6%	12.6%	1.3%	3679
Pereira	48.3%	18.1%	18.6%	14.1%	1.0%	3671
Piedecuesta	51.1%	20.1%	16.0%	12.5%	0.3%	1187
Pitalito	43.7%	20.9%	19.0%	15.5%	1.0%	1112
Popayán	49.9%	18.2%	16.3%	14.3%	1.3%	2345
Putumayo	41.1%	21.0%	19.3%	16.9%	1.7%	2502
Quibdó	33.1%	24.4%	20.3%	20.1%	2.1%	1233
Quindío	41.9%	21.7%	21.0%	14.7%	0.7%	2071
Riohacha	40.1%	20.7%	19.7%	18.6%	1.0%	1323
Rionegro	47.6%	21.6%	16.4%	13.3%	1.1%	1074
Risaralda	41.0%	23.2%	19.5%	15.0%	1.3%	1908
Sabaneta	55.4%	15.6%	14.1%	8.2%	6.7%	525
Sahagún	38.1%	23.3%	22.9%	15.2%	0.5%	1089
San Andrés	36.1%	22.3%	17.8%	20.9%	2.9%	449
Santa Marta	38.1%	21.7%	20.4%	18.1%	1.7%	4139
Santander	47.3%	20.6%	17.6%	13.8%	0.8%	6241

Continúa en la siguiente página

ETC/País	A	B	C	D	Omisión y multimarca	N° estudiantes
Sincelejo	44.8%	19.3%	20.3%	14.6%	0.9%	2462
Soacha	47.2%	20.7%	17.8%	13.2%	1.1%	4523
Sogamoso	54.5%	18.9%	14.9%	9.6%	2.1%	1361
Soledad	44.9%	20.8%	17.6%	15.6%	1.2%	3637
Sucre	35.3%	22.3%	21.7%	19.5%	1.2%	5370
Tolima	38.8%	21.4%	20.6%	17.6%	1.6%	6918
Tuluá	46.3%	21.4%	17.1%	14.4%	0.8%	1849
Tumaco	31.0%	24.1%	20.3%	22.8%	1.8%	1327
Tunja	58.3%	15.9%	14.6%	9.5%	1.7%	1487
Turbo	28.5%	23.5%	25.1%	20.4%	2.4%	999
Uribe	33.6%	21.6%	21.2%	22.6%	1.0%	292
Valle del Cauca	40.0%	21.1%	19.2%	17.3%	2.5%	6865
Valledupar	42.9%	20.4%	16.1%	15.1%	5.6%	3940
Vaupés	31.6%	21.7%	13.8%	26.3%	6.6%	152
Vichada	43.5%	19.0%	19.3%	17.8%	0.4%	269
Villavicencio	48.3%	20.3%	17.0%	13.1%	1.3%	3946
Yopal	48.8%	19.7%	17.0%	13.4%	1.2%	1271
Zipaquirá	53.2%	16.5%	17.7%	12.3%	0.4%	1108
Colombia	45.5%	20.2%	17.8%	14.8%	1.6%	366383

*Es posible que los porcentajes mostrados no sumen exactamente 100 debido a aproximaciones decimales.



- **Pregunta 18.**

En la tabla se presentan las frecuencias en *hertz* de la nota musical "La". A menudo se le denomina "nota de afinar". Se produce un "La de afinar" cuando el aire vibra 440 veces por segundo, es decir, a 440 *hertz*. Como se ve en la tabla, esta nota se encuentra en la tercera octava.

Octava musical	Primera Octava	Segunda Octava	Tercera Octava	Cuarta Octava
Frecuencia en <i>hertz</i>	110	220	440	

Tabla

NOTA: en música, una octava es el intervalo que separa dos sonidos cuyas frecuencias tienen una relación del doble. Para calcular la frecuencia en hertz en la cuarta octava se debe multiplicar 110 con

- A. 2^3
- B. 2^4
- C. 3^2
- D. 4^2

- **Estructura**

Competencia	Resolución
Componente	Numérico - variacional
Afirmación	Resolver problemas en situaciones de variación con funciones polinómicas y exponenciales en contextos aritméticos y geométricos.
Nivel de desempeño	Avanzado
Respuesta Correcta	A

• Resultados a nivel nacional y de Entidad Territorial Certificada (ETC)

ETC/País	A	B	C	D	Omisión y multimarca	N° estudiantes
Amazonas	27.2%	27.3%	18.5%	23.9%	3.1%	589
Antioquia	30.6%	25.7%	18.4%	22.5%	2.7%	16846
Apartadó	33.3%	24.4%	19.2%	21.7%	1.4%	1019
Arauca	33.0%	25.4%	18.8%	22.1%	0.7%	1614
Armenia	33.4%	25.8%	19.0%	21.2%	0.6%	2415
Atlántico	30.4%	26.3%	19.4%	22.3%	1.7%	4578
Barrancabermeja	34.6%	25.0%	18.5%	21.2%	0.7%	1899
Barranquilla	37.0%	24.2%	17.5%	20.0%	1.4%	9988
Bello	36.1%	25.2%	17.6%	20.3%	0.8%	3092
Bogotá, D.C.	37.1%	23.3%	17.4%	21.1%	1.2%	60321
Bolívar	29.9%	26.4%	19.1%	23.1%	1.5%	7070
Boyacá	36.0%	23.7%	18.1%	21.1%	1.0%	7298
Bucaramanga	41.9%	22.9%	16.3%	17.3%	1.7%	4681
Buenaventura	33.3%	23.7%	16.8%	24.6%	1.5%	2198
Buga	33.4%	24.8%	18.9%	21.2%	1.8%	884
Caldas	29.9%	25.6%	19.7%	24.1%	0.7%	4244
Cali	35.0%	24.5%	18.0%	20.5%	1.9%	16005
Caquetá	28.0%	26.4%	20.4%	22.7%	2.5%	1587
Cartagena	36.2%	24.8%	16.4%	20.6%	2.0%	8877
Cartago	32.7%	25.2%	21.8%	19.0%	1.3%	865
Casanare	30.9%	26.5%	20.1%	21.3%	1.3%	2075
Cauca	30.7%	24.9%	18.8%	23.5%	2.2%	7914
Cesar	35.0%	25.7%	18.5%	19.9%	0.9%	5112
Chocó	27.6%	25.6%	19.8%	25.5%	1.5%	1896
Chía	34.8%	25.6%	17.6%	21.4%	0.5%	1289
Ciénaga	31.4%	27.3%	17.4%	22.8%	1.2%	997
Cundinamarca	34.3%	24.6%	18.0%	21.4%	1.6%	13471
Córdoba	28.2%	26.1%	20.1%	24.5%	1.1%	8801
Cúcuta	37.1%	23.9%	18.7%	19.8%	0.5%	6040
Dosquebradas	31.5%	26.2%	19.6%	21.7%	1.0%	1265
Duitama	46.4%	19.2%	16.5%	17.2%	0.7%	1067
Envigado	41.6%	24.4%	14.8%	18.2%	1.0%	1677
Facatativá	35.3%	22.6%	19.0%	22.1%	1.0%	1064
Florencia	34.5%	25.7%	17.3%	22.3%	0.2%	1285
Floridablanca	42.4%	22.5%	16.9%	17.6%	0.6%	2014
Fusagasugá	31.7%	24.8%	20.1%	23.0%	0.4%	1228
Girardot	23.8%	27.9%	22.0%	25.3%	1.1%	901

Continúa en la siguiente página

ETC/País	A	B	C	D	Omisión y multimarca	N° estudiantes
Girón	36.6%	23.5%	17.8%	20.8%	1.3%	945
Guainía	32.3%	21.3%	17.7%	26.2%	2.4%	164
Guaviare	32.3%	23.5%	19.7%	21.6%	3.0%	575
Huila	32.9%	25.2%	18.6%	22.2%	1.1%	5160
Ibagué	34.4%	24.8%	18.5%	21.3%	1.0%	4329
Ipiales	42.1%	22.6%	16.0%	18.5%	0.8%	1011
Itagüí	39.2%	25.6%	15.3%	18.4%	1.6%	1498
Jamundí	27.8%	27.0%	17.7%	26.2%	1.2%	885
La Guajira	32.1%	25.7%	19.0%	21.8%	1.4%	1790
Lorica	24.6%	26.6%	23.1%	25.3%	0.4%	1167
Magangué	29.0%	25.7%	19.2%	21.0%	5.1%	903
Magdalena	28.9%	25.7%	20.9%	22.9%	1.6%	5178
Maicao	29.8%	27.4%	19.8%	22.7%	0.4%	1132
Malambo	39.1%	21.9%	15.3%	22.6%	1.2%	837
Manizales	35.4%	24.8%	19.0%	20.0%	0.7%	2878
Medellín	34.1%	25.1%	18.4%	20.8%	1.6%	16966
Meta	29.4%	25.8%	19.6%	24.2%	1.0%	3388
Montería	34.1%	25.3%	18.8%	21.0%	0.8%	3981
Mosquera	32.8%	27.0%	17.0%	22.4%	0.9%	1037
Nariño	35.7%	23.0%	18.0%	22.0%	1.3%	5979
Neiva	35.7%	25.1%	16.8%	21.4%	1.0%	3004
Norte de Santander	33.8%	25.1%	18.2%	22.2%	0.7%	4838
Palmira	37.9%	24.4%	17.9%	18.7%	1.1%	2248
Pasto	39.6%	23.7%	16.9%	18.6%	1.1%	3679
Pereira	33.9%	25.6%	18.1%	21.5%	0.8%	3671
Piedecuesta	38.3%	22.7%	15.8%	22.8%	0.4%	1187
Pitalito	37.8%	24.7%	16.6%	20.2%	0.6%	1112
Popayán	41.1%	22.4%	16.4%	18.8%	1.2%	2345
Putumayo	33.2%	25.1%	18.2%	22.0%	1.5%	2502
Quibdó	29.0%	27.6%	19.0%	22.6%	1.9%	1233
Quindío	30.4%	26.4%	19.7%	22.5%	0.9%	2071
Riohacha	32.2%	25.0%	19.7%	22.2%	0.9%	1323
Rionegro	35.3%	24.7%	18.5%	20.9%	0.7%	1074
Risaralda	30.1%	26.2%	19.9%	23.2%	0.6%	1908
Sabaneta	39.0%	24.0%	13.3%	17.1%	6.5%	525
Sahagún	27.8%	27.1%	21.7%	23.2%	0.2%	1089
San Andrés	35.4%	22.7%	18.9%	20.9%	2.0%	449
Santa Marta	31.3%	25.4%	20.1%	21.8%	1.4%	4139
Santander	35.8%	24.4%	17.4%	22.0%	0.6%	6241

Continúa en la siguiente página

ETC/País	A	B	C	D	Omisión y multimarca	N° estudiantes
Sincelejo	32.7%	26.4%	17.6%	22.3%	1.0%	2462
Soacha	32.2%	25.8%	18.8%	22.2%	0.9%	4523
Sogamoso	38.4%	22.1%	17.6%	19.9%	1.9%	1361
Soledad	35.5%	26.2%	18.6%	18.8%	1.0%	3637
Sucre	27.0%	26.4%	20.7%	24.9%	1.0%	5370
Tolima	29.3%	26.0%	20.2%	23.0%	1.5%	6918
Tuluá	31.8%	26.3%	20.3%	21.4%	0.3%	1849
Tumaco	28.1%	26.0%	20.9%	23.7%	1.2%	1327
Tunja	38.3%	25.7%	15.5%	19.0%	1.5%	1487
Turbo	23.6%	30.3%	21.1%	23.2%	1.7%	999
Uribia	23.3%	30.8%	15.8%	29.1%	1.0%	292
Valle del Cauca	29.7%	26.4%	19.0%	22.6%	2.3%	6865
Valledupar	31.6%	24.5%	17.2%	21.5%	5.3%	3940
Vaupés	24.3%	28.9%	18.4%	21.7%	6.6%	152
Vichada	30.9%	24.5%	19.0%	24.5%	1.1%	269
Villavicencio	36.0%	24.6%	18.1%	20.5%	0.8%	3946
Yopal	32.6%	25.3%	19.1%	22.0%	1.1%	1271
Zipaquirá	39.8%	22.7%	16.8%	20.3%	0.4%	1108
Colombia	34.0%	24.8%	18.3%	21.5%	1.4%	366383

*Es posible que los porcentajes mostrados no sumen exactamente 100 debido a aproximaciones decimales.

• **Pregunta 19.**

En la figura aparece el pentágono $CDEFG$ cuyos vértices están sobre las diagonales del pentágono $MNOPQ$; y se cumplen las siguientes relaciones: $\triangle CDE$ congruente con $\triangle CGF$, $\triangle MNO$ congruente con $\triangle MQP$ y $\triangle MNO$ semejante a $\triangle CDE$.

Con la información anterior **NO** es correcto concluir

- A. $\triangle MNO$ semejante a $\triangle CGF$.
- B. $\triangle MQP$ semejante a $\triangle CGF$.
- C. $\triangle MNO$ semejante a $\triangle CEF$.
- D. $\triangle MQP$ semejante a $\triangle CDE$.

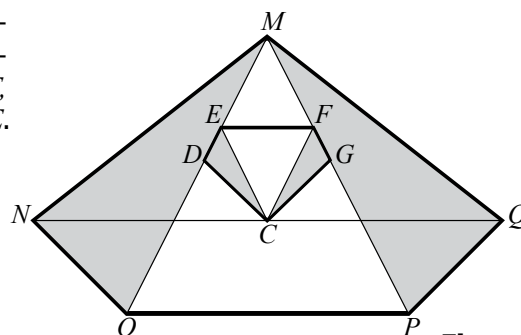

Figura

• **Estructura**

Competencia	Razonamiento
Componente	Espacial - métrico
Afirmación	Hacer conjeturas y verificar propiedades de congruencias y semejanza entre figuras bidimensionales.
Nivel de desempeño	Avanzado
Respuesta Correcta	C

• Resultados a nivel nacional y de Entidad Territorial Certificada (ETC)

ETC/País	A	B	C	D	Omisión y multimarca	N° estudiantes
Amazonas	18.7%	27.5%	32.6%	17.1%	4.1%	589
Antioquia	17.5%	25.2%	37.8%	16.6%	3.0%	16846
Apartadó	16.6%	26.4%	39.4%	16.4%	1.3%	1019
Arauca	17.5%	24.5%	40.6%	16.6%	0.8%	1614
Armenia	16.6%	24.3%	43.0%	15.0%	1.1%	2415
Atlántico	18.8%	24.4%	36.9%	17.9%	2.1%	4578
Barrancabermeja	18.8%	24.0%	39.8%	16.5%	0.9%	1899
Barranquilla	18.2%	23.1%	42.1%	15.0%	1.7%	9988
Bello	18.0%	25.0%	41.2%	14.6%	1.2%	3092
Bogotá, D.C.	16.7%	21.3%	45.7%	14.8%	1.4%	60321
Bolívar	18.2%	27.0%	35.4%	17.3%	2.1%	7070
Boyacá	17.2%	23.8%	42.2%	15.7%	1.1%	7298
Bucaramanga	17.5%	19.3%	47.3%	14.3%	1.6%	4681
Buenaventura	19.5%	26.3%	35.0%	17.4%	1.9%	2198
Buga	17.1%	24.3%	39.4%	17.2%	2.0%	884
Caldas	18.2%	24.0%	39.9%	16.8%	1.0%	4244
Cali	17.5%	23.4%	41.8%	15.1%	2.2%	16005
Caquetá	16.1%	27.1%	39.3%	15.0%	2.6%	1587
Cartagena	17.7%	24.8%	39.7%	15.5%	2.3%	8877
Cartago	18.4%	24.5%	40.3%	15.3%	1.5%	865
Casanare	16.9%	25.3%	41.3%	15.1%	1.4%	2075
Cauca	16.7%	24.9%	38.2%	17.6%	2.6%	7914
Cesar	16.9%	25.2%	40.6%	16.2%	1.1%	5112
Chocó	19.1%	26.5%	31.9%	20.3%	2.2%	1896
Chía	13.8%	21.0%	47.6%	16.4%	1.2%	1289
Ciénaga	20.2%	27.2%	31.3%	19.3%	2.1%	997
Cundinamarca	16.1%	22.2%	44.3%	15.7%	1.7%	13471
Córdoba	17.3%	26.4%	36.0%	18.9%	1.4%	8801
Cúcuta	18.3%	22.3%	43.7%	15.0%	0.8%	6040
Dosquebradas	17.2%	26.5%	39.4%	15.4%	1.5%	1265
Duitama	13.8%	18.0%	54.5%	13.1%	0.6%	1067
Envigado	17.1%	22.0%	48.1%	12.0%	0.9%	1677
Facatativá	17.8%	22.9%	43.4%	14.6%	1.3%	1064
Florencia	19.1%	24.1%	40.5%	15.8%	0.5%	1285
Floridablanca	16.6%	18.5%	49.5%	14.5%	0.9%	2014
Fusagasugá	19.0%	19.5%	44.2%	16.7%	0.7%	1228
Girardot	18.2%	25.9%	38.1%	16.5%	1.3%	901

Continúa en la siguiente página



ETC/País	A	B	C	D	Omisión y multimarca	N° estudiantes
Girón	16.4%	20.1%	47.4%	15.0%	1.1%	945
Guainía	18.3%	17.7%	37.2%	23.2%	3.7%	164
Guaviare	14.4%	28.2%	37.9%	16.3%	3.1%	575
Huila	16.4%	23.7%	43.1%	15.6%	1.2%	5160
Ibagué	17.7%	23.2%	42.8%	15.1%	1.2%	4329
Ipiales	15.1%	23.8%	44.7%	14.8%	1.5%	1011
Itagüí	18.8%	27.6%	36.4%	15.1%	2.0%	1498
Jamundí	18.6%	21.0%	40.7%	18.1%	1.6%	885
La Guajira	17.4%	27.7%	35.8%	17.4%	1.7%	1790
Lorica	18.8%	27.6%	35.0%	18.2%	0.5%	1167
Magangué	15.2%	25.0%	38.6%	15.0%	6.2%	903
Magdalena	19.4%	26.5%	32.7%	19.2%	2.1%	5178
Maicao	19.5%	25.5%	36.9%	17.2%	0.8%	1132
Malambo	18.4%	25.2%	42.3%	12.8%	1.3%	837
Manizales	18.1%	24.4%	41.6%	15.2%	0.8%	2878
Medellín	17.6%	24.0%	41.6%	14.9%	1.9%	16966
Meta	17.3%	24.9%	40.1%	16.6%	1.1%	3388
Montería	18.0%	24.0%	40.4%	16.6%	1.1%	3981
Mosquera	16.6%	22.9%	43.0%	16.5%	1.1%	1037
Nariño	17.6%	22.9%	39.9%	17.8%	1.7%	5979
Neiva	17.1%	21.0%	45.4%	15.2%	1.3%	3004
Norte de Santander	17.8%	23.2%	41.5%	16.6%	0.9%	4838
Palmira	16.9%	21.2%	46.8%	14.1%	1.1%	2248
Pasto	16.9%	21.9%	45.3%	14.7%	1.2%	3679
Pereira	17.4%	22.3%	43.6%	15.7%	1.0%	3671
Piedecuesta	16.5%	24.3%	44.0%	14.7%	0.5%	1187
Pitalito	17.1%	24.9%	39.9%	17.4%	0.6%	1112
Popayán	17.6%	20.3%	44.7%	15.6%	1.7%	2345
Putumayo	14.7%	25.5%	41.6%	16.5%	1.7%	2502
Quibdó	17.8%	27.5%	34.9%	17.9%	1.9%	1233
Quindío	17.8%	24.6%	41.9%	14.6%	1.1%	2071
Riohacha	20.9%	26.0%	35.9%	15.9%	1.3%	1323
Rionegro	17.0%	21.1%	44.3%	16.5%	1.0%	1074
Risaralda	18.6%	26.7%	38.5%	15.5%	0.8%	1908
Sabaneta	18.9%	19.0%	42.7%	12.8%	6.7%	525
Sahagún	16.5%	25.0%	40.8%	16.9%	0.8%	1089
San Andrés	18.5%	33.6%	34.5%	11.4%	2.0%	449
Santa Marta	18.6%	27.0%	35.8%	16.9%	1.7%	4139
Santander	16.5%	23.1%	44.0%	15.8%	0.6%	6241

Continúa en la siguiente página

ETC/País	A	B	C	D	Omisión y multimarca	N° estudiantes
Sincelejo	18.0%	21.6%	42.3%	17.3%	0.9%	2462
Soacha	18.7%	25.2%	39.8%	15.2%	1.1%	4523
Sogamoso	15.8%	19.8%	46.6%	15.7%	2.1%	1361
Soledad	19.8%	23.4%	39.4%	16.1%	1.4%	3637
Sucre	19.3%	24.9%	36.7%	17.9%	1.2%	5370
Tolima	17.9%	26.4%	36.3%	17.6%	1.9%	6918
Tuluá	18.4%	23.9%	41.2%	16.0%	0.6%	1849
Tumaco	17.9%	26.1%	34.4%	20.0%	1.7%	1327
Tunja	17.7%	19.8%	47.0%	13.7%	1.8%	1487
Turbo	18.4%	27.2%	32.8%	19.1%	2.4%	999
Uribe	17.8%	20.9%	40.1%	19.9%	1.4%	292
Valle del Cauca	17.3%	24.7%	38.2%	17.0%	2.7%	6865
Valledupar	17.9%	22.8%	38.4%	15.3%	5.7%	3940
Vaupés	9.9%	21.7%	35.5%	25.0%	7.9%	152
Vichada	13.8%	29.4%	38.3%	17.5%	1.1%	269
Villavicencio	16.0%	23.5%	44.0%	15.5%	1.0%	3946
Yopal	16.4%	21.1%	45.1%	16.4%	1.0%	1271
Zipaquirá	17.3%	23.0%	45.9%	13.3%	0.5%	1108
Colombia	17.4%	23.6%	41.4%	15.9%	1.6%	366383

*Es posible que los porcentajes mostrados no sumen exactamente 100 debido a aproximaciones decimales.

• **Pregunta 20.**

La siguiente gráfica muestra el pronóstico de la temperatura (en °C) para una ciudad, durante las 24 horas de un determinado día.

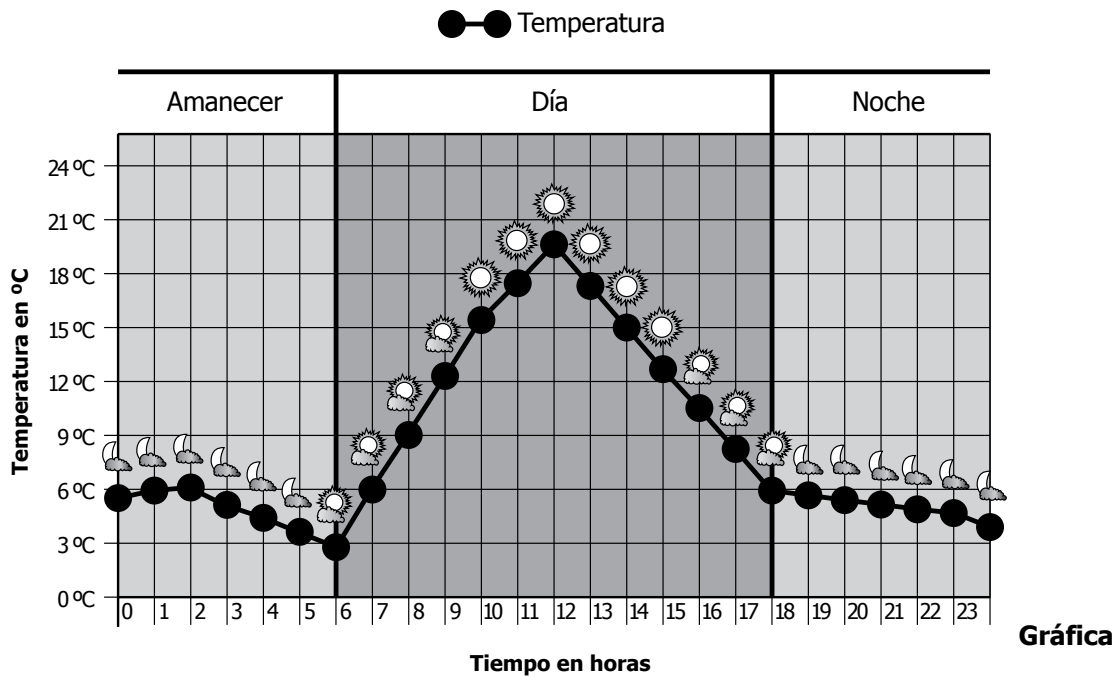

Tomado de: timeanddate.com

¿Cuál(es) de las siguientes afirmaciones es (son) verdadera(s)?

- I. La temperatura más alta se registrará a medio día.
- II. Durante las 6 horas de la noche la temperatura irá disminuyendo.
- III. En las 3 primeras horas del amanecer la temperatura se mantendrá constante.

- A. I solamente.
- B. III solamente.
- C. II y III solamente.
- D. I y II solamente.

- Estructura

Competencia	Comunicación
Componente	Numérico - variacional
Afirmación	Identificar características de gráficas cartesianas en relación con la situación que representan.
Nivel de desempeño	Satisfactorio
Respuesta Correcta	D

- Resultados a nivel nacional y de Entidad Territorial Certificada (ETC)

ETC/País	A	B	C	D	Omisión y multimarca	Nº estudiantes
Amazonas	31.4%	13.4%	17.1%	34.1%	3.9%	589
Antioquia	22.7%	10.8%	15.7%	47.9%	2.9%	16846
Apartadó	26.0%	15.0%	15.4%	41.8%	1.8%	1019
Arauca	21.7%	9.9%	14.3%	53.4%	0.7%	1614
Armenia	17.6%	10.6%	14.9%	56.1%	0.9%	2415
Atlántico	25.7%	13.1%	16.9%	42.2%	2.1%	4578
Barrancabermeja	19.4%	10.0%	15.8%	54.0%	0.8%	1899
Barranquilla	21.7%	9.6%	16.8%	50.5%	1.4%	9988
Bello	18.5%	9.9%	14.8%	55.7%	1.0%	3092
Bogotá, D.C.	15.6%	6.5%	12.7%	64.0%	1.2%	60321
Bolívar	27.8%	13.8%	19.1%	37.3%	1.9%	7070
Boyacá	21.4%	7.8%	13.5%	56.2%	1.2%	7298
Bucaramanga	14.3%	6.7%	12.0%	65.7%	1.3%	4681
Buenaventura	28.1%	13.1%	17.4%	39.4%	2.0%	2198
Buga	20.1%	7.2%	14.7%	56.3%	1.6%	884
Caldas	23.5%	10.3%	15.0%	50.2%	1.0%	4244
Cali	19.3%	8.8%	14.4%	55.7%	1.9%	16005
Caquetá	23.9%	13.4%	16.4%	43.7%	2.6%	1587
Cartagena	22.8%	12.0%	17.1%	45.8%	2.3%	8877
Cartago	20.0%	10.8%	13.3%	54.7%	1.3%	865
Casanare	20.6%	9.4%	14.4%	54.3%	1.3%	2075
Cauca	27.0%	10.3%	15.7%	44.5%	2.5%	7914
Cesar	24.6%	12.9%	16.6%	44.5%	1.4%	5112
Chocó	31.3%	18.1%	18.0%	30.5%	2.1%	1896
Chía	14.9%	4.3%	10.9%	69.4%	0.5%	1289

Continúa en la siguiente página



ETC/País	A	B	C	D	Omisión y multimarca	N° estudiantes
Ciénaga	29.3%	14.9%	20.4%	33.7%	1.7%	997
Cundinamarca	18.5%	7.3%	13.0%	59.5%	1.8%	13471
Córdoba	29.8%	12.9%	17.2%	38.6%	1.5%	8801
Cúcuta	19.4%	9.4%	14.1%	56.6%	0.6%	6040
Dosquebradas	20.9%	7.1%	13.9%	56.8%	1.2%	1265
Duitama	10.4%	3.7%	12.7%	72.6%	0.7%	1067
Envigado	13.7%	7.7%	11.9%	65.8%	0.9%	1677
Facatativá	15.8%	6.0%	12.6%	64.4%	1.2%	1064
Florencia	21.6%	6.8%	15.0%	55.9%	0.7%	1285
Floridablanca	15.8%	6.1%	12.3%	65.4%	0.4%	2014
Fusagasugá	17.2%	6.0%	13.8%	62.5%	0.5%	1228
Girardot	24.0%	10.3%	19.9%	45.1%	0.8%	901
Girón	16.3%	6.1%	13.8%	62.9%	1.0%	945
Guainía	27.4%	12.8%	14.0%	42.7%	3.0%	164
Guaviare	26.3%	11.5%	15.7%	43.0%	3.7%	575
Huila	22.7%	9.1%	13.9%	53.0%	1.4%	5160
Ibagué	18.7%	8.6%	14.1%	57.4%	1.2%	4329
Ipiales	17.2%	5.6%	13.2%	63.3%	0.7%	1011
Itagüí	18.4%	13.3%	17.3%	49.3%	1.7%	1498
Jamundí	22.6%	10.3%	13.9%	52.2%	1.0%	885
La Guajira	26.9%	13.2%	17.9%	40.3%	1.6%	1790
Lorica	31.4%	15.5%	19.9%	31.9%	1.4%	1167
Magangué	24.7%	10.4%	15.8%	43.9%	5.2%	903
Magdalena	31.7%	14.5%	18.2%	33.5%	2.0%	5178
Maicao	27.3%	15.1%	18.1%	38.9%	0.6%	1132
Malambo	21.4%	10.3%	15.1%	51.9%	1.4%	837
Manizales	17.2%	7.8%	15.8%	58.4%	0.8%	2878
Medellín	18.4%	10.5%	15.9%	53.4%	1.7%	16966
Meta	22.6%	11.0%	15.3%	50.2%	0.9%	3388
Montería	22.5%	9.4%	16.0%	51.0%	1.1%	3981
Mosquera	15.1%	4.6%	13.4%	65.9%	1.0%	1037
Nariño	20.7%	8.1%	14.0%	55.5%	1.6%	5979
Neiva	18.6%	7.9%	13.0%	59.3%	1.1%	3004
Norte de Santander	22.1%	8.8%	14.6%	53.6%	0.9%	4838
Palmira	17.1%	8.1%	16.0%	57.3%	1.5%	2248
Pasto	15.6%	7.2%	12.6%	63.4%	1.2%	3679
Pereira	18.3%	8.4%	14.7%	57.4%	1.1%	3671
Piedecuesta	17.2%	8.3%	15.1%	58.6%	0.9%	1187
Pitalito	21.0%	9.1%	14.4%	54.9%	0.5%	1112

Continúa en la siguiente página

ETC/País	A	B	C	D	Omisión y multimarca	N° estudiantes
Popayán	18.6%	7.0%	12.8%	60.8%	0.9%	2345
Putumayo	24.0%	8.8%	14.5%	51.3%	1.4%	2502
Quibdó	25.5%	15.0%	20.0%	37.2%	2.3%	1233
Quindío	19.7%	9.6%	16.1%	53.5%	1.1%	2071
Riohacha	25.5%	11.0%	16.3%	46.3%	1.0%	1323
Rionegro	18.4%	7.5%	16.2%	57.2%	0.7%	1074
Risaralda	23.8%	9.6%	15.3%	50.5%	0.7%	1908
Sabaneta	12.6%	4.4%	16.0%	60.2%	6.9%	525
Sahagún	23.9%	10.7%	16.5%	48.1%	0.8%	1089
San Andrés	21.4%	14.0%	21.2%	41.0%	2.4%	449
Santa Marta	23.6%	13.9%	18.1%	42.8%	1.6%	4139
Santander	19.8%	6.7%	13.1%	59.8%	0.7%	6241
Sincedejo	23.2%	8.5%	15.2%	51.8%	1.3%	2462
Soacha	18.6%	8.0%	15.2%	57.1%	1.1%	4523
Sogamoso	15.3%	5.1%	10.9%	66.6%	2.1%	1361
Soledad	22.4%	9.6%	16.6%	50.2%	1.3%	3637
Sucre	29.1%	12.0%	17.2%	40.1%	1.6%	5370
Tolima	24.4%	11.0%	15.9%	47.0%	1.8%	6918
Tuluá	21.4%	8.8%	15.7%	53.3%	0.7%	1849
Tumaco	28.6%	15.8%	18.5%	35.2%	1.8%	1327
Tunja	13.6%	6.3%	12.2%	66.4%	1.5%	1487
Turbo	29.4%	13.4%	20.4%	34.3%	2.4%	999
Uribe	38.0%	12.0%	15.1%	33.2%	1.7%	292
Valle del Cauca	23.7%	9.2%	15.9%	48.8%	2.4%	6865
Valledupar	23.1%	9.8%	15.4%	46.1%	5.5%	3940
Vaupés	34.2%	10.5%	12.5%	36.2%	6.6%	152
Vichada	26.0%	11.5%	14.1%	47.2%	1.1%	269
Villavicencio	17.9%	8.8%	13.9%	58.3%	1.1%	3946
Yopal	17.5%	7.2%	12.6%	61.9%	0.9%	1271
Zipaquirá	14.9%	7.3%	11.3%	66.2%	0.3%	1108
Colombia	20.8%	9.3%	14.9%	53.4%	1.6%	366383

*Es posible que los porcentajes mostrados no sumen exactamente 100 debido a aproximaciones decimales.

• **Pregunta 21.**

La gráfica representa el nivel de concentración de azúcar en la sangre, medida en miligramos por decilitro (mg/dL), de tres personas, durante 6 horas

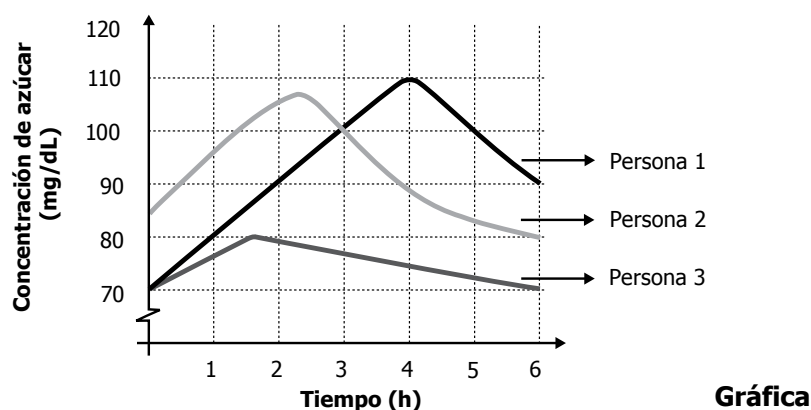

- | |
|--|
| <p>I. La concentración de azúcar en la sangre de la persona 3 fue constante durante las seis horas.</p> <p>II. la concentración de azúcar en la sangre de las tres personas disminuyó durante las dos últimas horas.</p> <p>III. La concentración de azúcar en la sangre de las personas 1 y 2 aumentó durante las dos primeras horas.</p> |
|--|

¿Cuál(es) de las anteriores afirmaciones es (son) verdadera(s)?

- A. I solamente.
- B. II solamente.
- C. I y III solamente.
- D. II y III solamente.

• **Estructura**

Competencia	Comunicación
Componente	Numérico - variacional
Afirmación	Identificar características de gráficas cartesianas en relación con la situación que representan.
Nivel de desempeño	Satisfactorio
Respuesta Correcta	D

• Resultados a nivel nacional y de Entidad Territorial Certificada (ETC)

ETC/País	A	B	C	D	Omisión y multimarca	N° estudiantes
Amazonas	15.3%	26.5%	25.1%	28.7%	4.4%	589
Antioquia	12.9%	22.8%	23.2%	37.9%	3.2%	16846
Apartadó	17.8%	23.1%	24.7%	33.1%	1.4%	1019
Arauca	13.4%	23.2%	22.4%	40.0%	1.1%	1614
Armenia	12.5%	20.4%	23.9%	42.3%	1.0%	2415
Atlántico	14.8%	24.7%	23.6%	34.6%	2.4%	4578
Barrancabermeja	11.2%	22.7%	24.3%	41.0%	0.8%	1899
Barranquilla	11.7%	21.9%	22.3%	42.5%	1.6%	9988
Bello	11.1%	20.6%	21.6%	45.8%	1.0%	3092
Bogotá, D.C.	8.6%	20.2%	19.9%	49.8%	1.4%	60321
Bolívar	15.7%	23.6%	27.2%	31.2%	2.3%	7070
Boyacá	11.5%	23.5%	22.0%	41.7%	1.2%	7298
Bucaramanga	8.1%	21.1%	18.6%	50.7%	1.5%	4681
Buenaventura	16.1%	22.5%	24.9%	34.2%	2.3%	2198
Buga	11.0%	24.9%	22.7%	38.8%	2.6%	884
Caldas	12.7%	24.2%	22.8%	39.4%	0.9%	4244
Cali	11.1%	22.0%	21.4%	43.4%	2.1%	16005
Caquetá	13.8%	23.5%	26.4%	33.7%	2.6%	1587
Cartagena	13.4%	22.6%	24.4%	37.1%	2.5%	8877
Cartago	11.0%	22.2%	21.6%	43.5%	1.7%	865
Casanare	12.3%	23.0%	23.3%	39.7%	1.7%	2075
Cauca	15.0%	22.9%	24.5%	34.8%	2.8%	7914
Cesar	14.9%	24.1%	24.4%	35.0%	1.5%	5112
Chocó	19.2%	26.2%	27.0%	25.1%	2.5%	1896
Chía	9.0%	20.1%	19.6%	50.5%	0.8%	1289
Ciénaga	14.9%	22.9%	26.4%	33.3%	2.5%	997
Cundinamarca	9.2%	22.4%	21.8%	44.7%	1.9%	13471
Córdoba	15.0%	24.9%	26.5%	32.0%	1.6%	8801
Cúcuta	11.2%	22.1%	21.8%	44.3%	0.7%	6040
Dosquebradas	10.9%	21.3%	22.1%	44.5%	1.2%	1265
Duitama	7.4%	21.8%	16.8%	53.1%	0.8%	1067
Envigado	9.0%	21.1%	18.0%	50.6%	1.3%	1677
Facatativá	8.4%	18.0%	20.0%	52.3%	1.3%	1064
Florencia	9.1%	23.7%	24.8%	41.5%	0.9%	1285
Floridablanca	7.8%	20.0%	20.1%	51.4%	0.6%	2014
Fusagasugá	10.1%	22.2%	20.6%	46.7%	0.3%	1228
Girardot	13.0%	20.5%	27.5%	38.0%	1.0%	901

Continúa en la siguiente página



ETC/País	A	B	C	D	Omisión y multimarca	N° estudiantes
Girón	8.8%	22.0%	21.8%	45.7%	1.7%	945
Guainía	17.7%	17.1%	25.6%	37.2%	2.4%	164
Guaviare	13.7%	26.1%	23.8%	32.5%	3.8%	575
Huila	11.7%	22.9%	23.4%	40.6%	1.4%	5160
Ibagué	10.7%	21.7%	21.7%	44.8%	1.2%	4329
Ipiales	9.5%	23.4%	18.4%	47.7%	1.0%	1011
Itagüí	14.3%	22.7%	23.5%	37.7%	1.9%	1498
Jamundí	11.3%	21.8%	24.4%	41.1%	1.4%	885
La Guajira	14.6%	24.6%	26.4%	32.6%	1.7%	1790
Lorica	16.5%	26.5%	28.0%	28.0%	1.0%	1167
Magangué	14.8%	24.5%	23.9%	31.6%	5.2%	903
Magdalena	16.7%	25.4%	26.4%	29.2%	2.3%	5178
Maicao	17.2%	24.1%	26.5%	31.4%	0.8%	1132
Malambo	11.0%	23.1%	22.7%	41.8%	1.4%	837
Manizales	10.0%	21.1%	22.5%	45.3%	1.1%	2878
Medellín	11.4%	21.4%	22.0%	43.2%	1.9%	16966
Meta	12.1%	23.5%	22.8%	40.4%	1.1%	3388
Montería	12.2%	22.3%	23.7%	40.8%	1.0%	3981
Mosquera	8.8%	18.0%	22.6%	49.8%	0.9%	1037
Nariño	11.7%	22.1%	22.7%	41.9%	1.7%	5979
Neiva	10.0%	21.3%	21.3%	46.1%	1.3%	3004
Norte de Santander	11.4%	22.9%	25.1%	39.9%	0.9%	4838
Palmira	10.3%	22.1%	21.3%	45.1%	1.3%	2248
Pasto	9.1%	21.1%	20.3%	48.2%	1.4%	3679
Pereira	10.1%	23.4%	20.9%	44.6%	0.9%	3671
Piedecuesta	8.9%	20.4%	20.7%	49.4%	0.6%	1187
Pitalito	11.8%	23.2%	22.3%	42.1%	0.6%	1112
Popayán	9.3%	21.4%	21.4%	46.7%	1.2%	2345
Putumayo	11.0%	24.0%	23.6%	39.6%	1.8%	2502
Quibdó	15.7%	24.2%	28.6%	29.0%	2.5%	1233
Quindío	12.4%	21.6%	23.8%	41.0%	1.2%	2071
Riohacha	16.7%	22.2%	24.1%	35.4%	1.6%	1323
Rionegro	9.9%	21.1%	20.9%	47.1%	0.9%	1074
Risaralda	11.7%	22.3%	24.2%	40.8%	1.0%	1908
Sabaneta	9.0%	18.7%	20.0%	45.5%	6.9%	525
Sahagún	11.2%	22.3%	26.0%	39.8%	0.7%	1089
San Andrés	15.1%	25.4%	24.3%	32.3%	2.9%	449
Santa Marta	14.8%	23.9%	23.7%	35.9%	1.7%	4139
Santander	10.5%	22.5%	21.6%	44.6%	0.8%	6241

Continúa en la siguiente página

ETC/País	A	B	C	D	Omisión y multimarca	N° estudiantes
Sincelejo	13.4%	21.9%	24.9%	38.8%	1.1%	2462
Soacha	10.8%	22.5%	22.2%	43.4%	1.2%	4523
Sogamoso	8.1%	22.6%	20.8%	46.3%	2.2%	1361
Soledad	12.6%	21.7%	23.3%	41.3%	1.2%	3637
Sucre	14.9%	23.5%	27.6%	32.8%	1.1%	5370
Tolima	13.4%	24.2%	24.5%	36.2%	1.8%	6918
Tuluá	11.6%	21.2%	21.7%	44.7%	0.8%	1849
Tumaco	17.3%	24.1%	27.9%	28.8%	2.0%	1327
Tunja	9.5%	21.5%	19.6%	47.7%	1.7%	1487
Turbo	16.0%	25.2%	28.4%	27.6%	2.7%	999
Uribe	15.4%	20.9%	27.7%	35.3%	0.7%	292
Valle del Cauca	11.5%	23.2%	23.2%	39.2%	2.8%	6865
Valledupar	13.0%	20.3%	23.8%	37.5%	5.4%	3940
Vaupés	17.8%	23.0%	21.7%	29.6%	7.9%	152
Vichada	11.2%	27.9%	27.1%	33.1%	0.7%	269
Villavicencio	10.1%	21.3%	21.0%	46.5%	1.1%	3946
Yopal	10.8%	21.2%	20.4%	46.3%	1.3%	1271
Zipaquirá	8.3%	20.8%	22.1%	48.5%	0.3%	1108
Colombia	11.6%	22.2%	22.6%	41.9%	1.7%	366383

*Es posible que los porcentajes mostrados no sumen exactamente 100 debido a aproximaciones decimales.

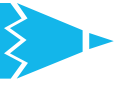

- **Pregunta 22 .**

Una marca de calzado ofrece 144 diseños diferentes. El número de diseños de calzado deportivo es el doble del número de diseños de calzado formal.

¿Cuántos diseños de calzado formal y cuántos de deportivo ofrece la marca?

- A. 48 y 96.
- B. 52 y 104.
- C. 71 y 73.
- D. 72 y 144.

- **Estructura**

Competencia	Resolución
Componente	Numérico - variacional
Afirmación	Resolver problemas que requieran para su solución ecuaciones lineales y sistemas de ecuaciones lineales.
Nivel de desempeño	Avanzado
Respuesta correcta	A

• Resultados a nivel nacional y de Entidad Territorial Certificada (ETC)

ETC/País	A	B	C	D	Omisión y multimarca	N° estudiantes
Amazonas	28.9%	16.3%	15.3%	35.7%	3.9%	589
Antioquia	38.9%	16.4%	13.8%	27.9%	3.0%	16846
Apartadó	44.5%	17.5%	12.8%	23.8%	1.5%	1019
Arauca	37.9%	17.0%	14.6%	29.7%	0.9%	1614
Armenia	42.4%	17.8%	13.7%	25.5%	0.6%	2415
Atlántico	36.4%	17.2%	14.7%	29.8%	1.9%	4578
Barrancabermeja	41.8%	16.8%	14.3%	26.1%	1.0%	1899
Barranquilla	43.9%	14.5%	13.8%	26.3%	1.4%	9988
Bello	44.1%	16.4%	13.0%	25.6%	0.9%	3092
Bogotá, D.C.	46.5%	15.8%	11.8%	24.5%	1.4%	60321
Bolívar	35.3%	18.2%	16.2%	28.5%	1.8%	7070
Boyacá	41.4%	16.1%	13.7%	27.6%	1.2%	7298
Bucaramanga	49.7%	13.9%	11.0%	23.9%	1.4%	4681
Buenaventura	36.2%	15.3%	14.0%	32.3%	2.2%	2198
Buga	39.3%	17.6%	11.9%	29.2%	2.0%	884
Caldas	37.6%	16.1%	15.0%	30.4%	1.0%	4244
Calí	43.1%	15.8%	12.9%	26.2%	1.9%	16005
Caquetá	33.3%	17.1%	15.0%	32.4%	2.3%	1587
Cartagena	42.3%	16.5%	12.6%	26.5%	2.2%	8877
Cartago	36.4%	19.2%	15.4%	27.3%	1.7%	865
Casanare	38.2%	19.2%	12.9%	28.0%	1.7%	2075
Cauca	32.9%	15.9%	14.7%	34.1%	2.4%	7914
Cesar	38.3%	16.6%	14.8%	29.0%	1.3%	5112
Chocó	29.6%	18.1%	14.4%	36.1%	1.7%	1896
Chía	46.8%	15.1%	11.1%	26.0%	1.1%	1289
Ciénaga	35.8%	14.0%	16.2%	32.2%	1.7%	997
Cundinamarca	42.8%	15.6%	13.2%	26.5%	1.9%	13471
Córdoba	31.9%	18.8%	15.9%	31.9%	1.5%	8801
Cúcuta	44.5%	16.3%	12.3%	26.4%	0.6%	6040
Dosquebradas	39.0%	17.7%	11.9%	30.1%	1.3%	1265
Duitama	54.3%	13.8%	10.4%	20.8%	0.7%	1067
Envigado	58.3%	14.8%	8.8%	17.1%	1.0%	1677
Facatativá	44.1%	14.0%	12.9%	27.6%	1.4%	1064
Florencia	38.8%	16.8%	12.4%	31.3%	0.8%	1285
Floridablanca	50.3%	15.0%	10.9%	23.1%	0.7%	2014
Fusagasugá	45.3%	14.7%	14.0%	25.7%	0.3%	1228
Girardot	35.2%	18.1%	16.4%	29.4%	0.9%	901

Continúa en la siguiente página



ETC/País	A	B	C	D	Omisión y multimarca	N° estudiantes
Girón	48.4%	15.3%	9.0%	25.9%	1.4%	945
Guainía	29.3%	14.0%	17.1%	37.2%	2.4%	164
Guaviare	29.7%	20.7%	14.6%	31.0%	4.0%	575
Huila	36.6%	17.6%	15.4%	29.0%	1.4%	5160
Ibagué	41.6%	15.3%	13.1%	28.7%	1.4%	4329
Ipiales	46.8%	13.5%	15.0%	23.7%	1.0%	1011
Itagüí	45.7%	17.9%	13.9%	20.4%	2.1%	1498
Jamundí	39.1%	15.8%	16.4%	27.5%	1.2%	885
La Guajira	33.8%	16.4%	14.8%	33.3%	1.7%	1790
Lorica	32.2%	18.2%	16.0%	33.1%	0.5%	1167
Magangué	35.1%	15.1%	14.8%	29.8%	5.2%	903
Magdalena	34.5%	17.1%	15.1%	31.4%	2.0%	5178
Maicao	34.9%	14.6%	16.8%	33.0%	0.8%	1132
Malambo	40.9%	15.4%	14.6%	27.7%	1.4%	837
Manizales	41.9%	18.8%	13.6%	24.8%	0.9%	2878
Medellín	44.9%	17.7%	12.9%	22.7%	1.8%	16966
Meta	37.9%	18.2%	13.0%	29.5%	1.4%	3388
Montería	41.4%	16.3%	13.7%	27.7%	1.0%	3981
Mosquera	45.0%	14.3%	11.9%	27.8%	1.1%	1037
Nariño	39.4%	14.2%	13.3%	31.5%	1.6%	5979
Neiva	42.5%	15.1%	13.6%	27.4%	1.3%	3004
Norte de Santander	39.7%	16.6%	13.4%	29.4%	0.9%	4838
Palmira	42.1%	15.6%	14.0%	26.7%	1.6%	2248
Pasto	46.8%	14.3%	12.7%	25.0%	1.3%	3679
Pereira	41.7%	16.2%	13.9%	27.2%	1.0%	3671
Piedecuesta	47.3%	14.2%	11.0%	26.6%	0.8%	1187
Pitalito	43.0%	16.6%	14.8%	24.7%	0.8%	1112
Popayán	46.6%	12.5%	12.3%	27.6%	1.1%	2345
Putumayo	37.6%	15.3%	14.8%	30.9%	1.4%	2502
Quibdó	33.3%	18.4%	13.9%	32.5%	1.9%	1233
Quindío	38.1%	19.3%	14.9%	26.7%	1.0%	2071
Riohacha	37.0%	15.5%	13.2%	33.1%	1.2%	1323
Rionegro	44.7%	17.8%	11.5%	25.1%	0.8%	1074
Risaralda	34.9%	17.6%	16.1%	30.8%	0.6%	1908
Sabaneta	49.9%	9.3%	11.4%	22.7%	6.7%	525
Sahagún	34.1%	18.1%	16.4%	30.9%	0.5%	1089
San Andrés	42.8%	16.0%	14.3%	24.1%	2.9%	449
Santa Marta	38.7%	17.2%	14.6%	28.0%	1.5%	4139
Santander	43.2%	15.3%	13.1%	27.8%	0.6%	6241

Continúa en la siguiente página

ETC/País	A	B	C	D	Omisión y multimarca	N° estudiantes
Sincelejo	41.1%	16.0%	13.2%	28.8%	0.9%	2462
Soacha	41.5%	16.2%	14.0%	27.2%	1.1%	4523
Sogamoso	48.4%	12.9%	12.2%	24.5%	2.1%	1361
Soledad	43.1%	16.0%	12.7%	27.1%	1.2%	3637
Sucre	32.6%	18.6%	14.4%	33.5%	0.9%	5370
Tolima	33.8%	16.6%	16.1%	32.0%	1.6%	6918
Tuluá	38.9%	17.3%	14.6%	28.7%	0.5%	1849
Tumaco	32.5%	17.8%	14.1%	33.8%	1.8%	1327
Tunja	46.9%	16.3%	11.8%	23.2%	1.8%	1487
Turbo	29.6%	18.8%	16.1%	33.1%	2.3%	999
Uribe	33.2%	12.3%	18.2%	35.3%	1.0%	292
Valle del Cauca	37.2%	16.8%	14.6%	28.7%	2.7%	6865
Valledupar	38.0%	15.2%	13.7%	27.6%	5.4%	3940
Vaupés	26.3%	11.8%	15.8%	33.6%	12.5%	152
Vichada	33.8%	20.1%	16.4%	28.6%	1.1%	269
Villavicencio	44.8%	16.8%	12.1%	25.4%	0.9%	3946
Yopal	45.9%	14.1%	12.7%	25.7%	1.6%	1271
Zipaquirá	49.9%	14.9%	11.0%	23.6%	0.6%	1108
Colombia	41.3%	16.3%	13.4%	27.4%	1.6%	366383

*Es posible que los porcentajes mostrados no sumen exactamente 100 debido a aproximaciones decimales.

• **Pregunta 23.**

La gráfica muestra información sobre los ingresos en millones de pesos de una empresa en los últimos 5 años.

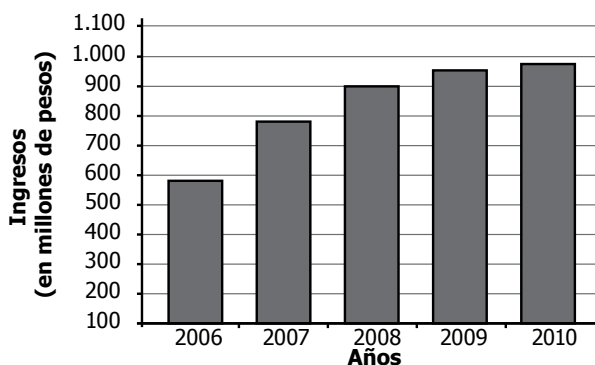

Gráfica

Si la tendencia se mantuvo, los ingresos de 2011 aumentaron respecto a los de 2010, aproximadamente,

- A. entre 10 y 14 millones de pesos.
- B. entre 17 y 21 millones de pesos.
- C. entre 24 y 28 millones de pesos.
- D. entre 31 y 35 millones de pesos.

• **Estructura**

Competencia	Razonamiento
Componente	Aleatorio
Afirmación	Formular inferencias y justificar razonamientos y conclusiones a partir del análisis de información estadística.
Nivel de desempeño	Avanzado
Respuesta Correcta	A

• Resultados a nivel nacional y de Entidad Territorial Certificada (ETC)

ETC/País	A	B	C	D	Omisión y multimarca	N° estudiantes
Amazonas	28.0%	18.2%	24.8%	24.4%	4.6%	589
Antioquia	37.5%	18.1%	22.3%	18.9%	3.3%	16846
Apartadó	36.8%	18.6%	23.4%	19.4%	1.8%	1019
Arauca	39.7%	18.6%	23.0%	17.3%	1.5%	1614
Armenia	38.3%	20.3%	23.2%	17.1%	1.1%	2415
Atlántico	33.6%	18.0%	23.7%	21.9%	2.8%	4578
Barrancabermeja	37.3%	17.4%	25.1%	18.5%	1.7%	1899
Barranquilla	40.2%	18.7%	22.2%	16.7%	2.1%	9988
Bello	41.5%	18.2%	21.0%	18.0%	1.4%	3092
Bogotá, D.C.	43.8%	18.0%	21.3%	15.0%	1.9%	60321
Bolívar	33.2%	17.0%	24.7%	22.7%	2.4%	7070
Boyacá	39.4%	18.8%	23.1%	17.0%	1.7%	7298
Bucaramanga	43.2%	18.8%	21.4%	14.8%	1.9%	4681
Buenaventura	36.9%	18.1%	21.2%	21.0%	2.8%	2198
Buga	37.3%	16.6%	27.0%	16.6%	2.4%	884
Caldas	39.4%	17.1%	23.8%	18.5%	1.2%	4244
Cali	42.1%	18.4%	21.3%	15.8%	2.5%	16005
Caquetá	35.9%	20.5%	23.0%	17.8%	2.8%	1587
Cartagena	38.7%	17.7%	22.0%	19.1%	2.5%	8877
Cartago	34.6%	18.2%	25.5%	19.9%	1.8%	865
Casanare	37.1%	18.0%	24.5%	18.2%	2.3%	2075
Cauca	35.4%	18.2%	23.3%	20.0%	3.1%	7914
Cesar	36.5%	18.4%	22.8%	20.9%	1.4%	5112
Chocó	29.9%	17.1%	23.3%	27.1%	2.6%	1896
Chía	42.7%	17.0%	24.0%	15.2%	1.2%	1289
Ciénaga	35.8%	17.4%	24.3%	20.2%	2.4%	997
Cundinamarca	40.5%	17.9%	22.4%	16.9%	2.3%	13471
Córdoba	32.7%	18.1%	24.0%	23.6%	1.6%	8801
Cúcuta	40.1%	18.5%	23.5%	17.0%	0.8%	6040
Dosquebradas	40.6%	19.4%	23.5%	14.9%	1.7%	1265
Duitama	46.3%	17.5%	21.7%	13.3%	1.1%	1067
Envigado	43.1%	18.0%	20.3%	17.2%	1.4%	1677
Facatativá	42.6%	16.9%	22.7%	16.1%	1.8%	1064
Florencia	40.2%	16.8%	23.2%	18.2%	1.6%	1285
Floridablanca	42.9%	17.8%	22.7%	15.6%	0.9%	2014
Fusagasugá	39.6%	18.8%	22.9%	17.3%	1.4%	1228
Girardot	33.7%	19.3%	26.5%	19.4%	1.0%	901

Continúa en la siguiente página



ETC/País	A	B	C	D	Omisión y multimarca	N° estudiantes
Girón	45.9%	16.1%	19.9%	16.1%	2.0%	945
Guainía	35.4%	22.6%	17.1%	23.2%	1.8%	164
Guaviare	34.1%	18.1%	24.7%	19.5%	3.7%	575
Huila	39.9%	18.1%	22.4%	17.8%	1.8%	5160
Ibagué	40.4%	18.1%	23.5%	16.2%	1.7%	4329
Ipiales	44.1%	17.7%	21.9%	15.0%	1.3%	1011
Itagüí	37.8%	19.8%	22.6%	17.7%	2.1%	1498
Jamundí	43.1%	16.3%	19.8%	19.1%	1.8%	885
La Guajira	35.6%	16.5%	23.8%	22.0%	2.1%	1790
Lorica	29.7%	19.5%	23.9%	25.9%	1.0%	1167
Magangué	36.1%	16.2%	22.9%	19.3%	5.5%	903
Magdalena	31.3%	18.0%	25.1%	23.2%	2.4%	5178
Maicao	33.6%	18.8%	24.3%	22.3%	1.0%	1132
Malambo	42.3%	19.1%	21.7%	15.4%	1.4%	837
Manizales	40.2%	18.9%	22.2%	17.7%	0.9%	2878
Medellín	39.4%	18.5%	22.2%	17.9%	2.1%	16966
Meta	36.6%	18.7%	23.8%	19.1%	1.7%	3388
Montería	37.8%	17.9%	23.1%	19.6%	1.6%	3981
Mosquera	42.7%	18.3%	20.8%	16.3%	1.8%	1037
Nariño	40.8%	16.6%	21.5%	18.9%	2.2%	5979
Neiva	41.9%	19.0%	21.6%	15.5%	1.9%	3004
Norte de Santander	39.5%	17.9%	22.7%	18.8%	1.2%	4838
Palmira	44.9%	15.7%	22.0%	15.3%	2.1%	2248
Pasto	42.5%	18.5%	20.5%	16.7%	1.8%	3679
Pereira	40.3%	17.2%	23.7%	17.3%	1.6%	3671
Piedecuesta	41.1%	18.3%	23.1%	16.8%	0.8%	1187
Pitalito	39.2%	18.1%	23.2%	18.8%	0.7%	1112
Popayán	45.4%	18.0%	21.4%	13.7%	1.6%	2345
Putumayo	37.5%	18.2%	23.3%	18.9%	2.0%	2502
Quibdó	30.3%	19.2%	24.9%	22.5%	3.2%	1233
Quindío	36.6%	19.9%	23.8%	18.3%	1.4%	2071
Riohacha	37.7%	17.7%	22.1%	20.8%	1.7%	1323
Rionegro	40.9%	18.2%	23.4%	16.4%	1.1%	1074
Risaralda	38.7%	17.1%	22.9%	20.2%	1.1%	1908
Sabaneta	38.3%	19.2%	20.2%	15.0%	7.2%	525
Sahagún	38.9%	18.6%	21.0%	20.5%	0.9%	1089
San Andrés	33.0%	19.8%	21.2%	22.7%	3.3%	449
Santa Marta	33.4%	19.4%	24.1%	21.1%	2.2%	4139
Santander	40.6%	18.2%	22.9%	17.4%	0.9%	6241

Continúa en la siguiente página

ETC/País	A	B	C	D	Omisión y multimarca	N° estudiantes
Sincelejo	37.5%	16.5%	25.7%	18.8%	1.5%	2462
Soacha	42.3%	17.9%	22.4%	15.9%	1.5%	4523
Sogamoso	43.4%	17.8%	21.1%	15.4%	2.4%	1361
Soledad	40.1%	16.9%	22.5%	19.1%	1.4%	3637
Sucre	33.9%	17.4%	24.3%	22.7%	1.7%	5370
Tolima	36.7%	17.8%	23.5%	19.8%	2.1%	6918
Tuluá	39.0%	18.6%	22.8%	18.6%	1.0%	1849
Tumaco	28.9%	16.7%	27.4%	24.6%	2.3%	1327
Tunja	43.1%	17.3%	21.5%	16.5%	1.5%	1487
Turbo	28.4%	19.9%	25.3%	23.2%	3.1%	999
Uribe	34.6%	16.1%	21.2%	26.4%	1.7%	292
Valle del Cauca	37.8%	17.7%	23.5%	18.0%	3.2%	6865
Valledupar	35.5%	17.9%	21.9%	18.9%	5.8%	3940
Vaupés	29.6%	15.1%	23.7%	17.1%	14.5%	152
Vichada	33.5%	16.0%	27.5%	21.6%	1.5%	269
Villavicencio	40.1%	19.2%	22.2%	17.1%	1.4%	3946
Yopal	40.4%	17.2%	24.2%	16.6%	1.6%	1271
Zipaquirá	41.7%	18.1%	22.0%	16.9%	1.3%	1108
Colombia	39.4%	18.1%	22.6%	18.0%	2.1%	366383

*Es posible que los porcentajes mostrados no sumen exactamente 100 debido a aproximaciones decimales.

• **Pregunta 24.**

La gráfica muestra el costo aproximado (en miles de pesos) del flete de transporte de carga desde Bogotá hacia algunos destinos de Colombia.

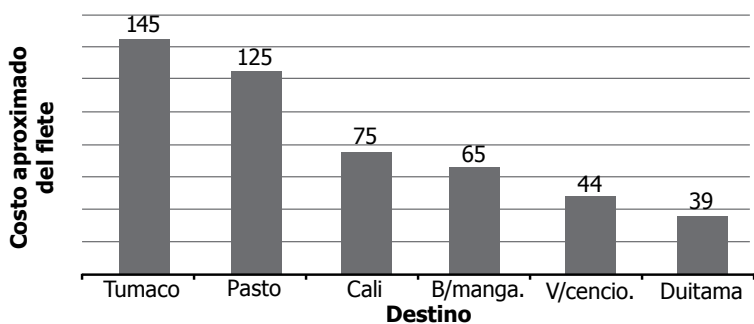

Gráfica

Tomado de Decreto 2663 de julio 21 de 2008 con base en la resolución 3175 de 2008

De acuerdo con la información de la gráfica, el costo promedio del flete (en miles de pesos), en estas ciudades, está entre

- A. 39 y 65
- B. 44 y 65
- C. 75 y 125
- D. 125 y 135

• **Estructura**

Competencia	Comunicación
Componente	Aleatorio
Afirmación	Reconocer la media, mediana y moda con base en la representación de un conjunto de datos y explicitar sus diferencias en distribuciones diferentes.
Nivel de desempeño	Avanzado
Respuesta Correcta	C

• Resultados a nivel nacional y de Entidad Territorial Certificada (ETC)

ETC/País	A	B	C	D	Omisión y multimarca	N° estudiantes
Amazonas	16.3%	16.1%	34.6%	31.2%	1.7%	589
Antioquia	18.4%	18.6%	38.2%	21.7%	3.1%	16848
Apartadó	22.4%	19.6%	37.3%	19.0%	1.7%	1018
Arauca	17.7%	20.0%	41.9%	19.2%	1.2%	1612
Armenia	18.6%	17.7%	43.9%	18.8%	1.0%	2415
Atlántico	20.0%	18.2%	37.2%	22.8%	1.8%	4581
Barrancabermeja	19.3%	20.3%	38.7%	20.2%	1.6%	1899
Barranquilla	19.4%	18.0%	41.0%	19.5%	2.1%	9986
Bello	19.8%	17.1%	42.5%	18.9%	1.6%	3094
Bogotá, D.C.	17.7%	17.9%	45.2%	17.5%	1.7%	60316
Bolívar	18.5%	19.4%	35.1%	25.0%	2.0%	7074
Boyacá	17.4%	19.9%	43.3%	18.1%	1.4%	7298
Bucaramanga	17.6%	20.3%	44.5%	15.4%	2.2%	4683
Buenaventura	19.1%	17.4%	36.7%	24.5%	2.2%	2198
Buga	13.7%	16.4%	42.7%	24.3%	3.0%	886
Caldas	16.8%	18.7%	40.6%	22.5%	1.4%	4246
Cali	16.2%	16.9%	44.2%	20.1%	2.6%	16005
Caquetá	17.0%	19.6%	38.5%	22.5%	2.3%	1584
Cartagena	20.4%	18.4%	39.2%	19.6%	2.4%	8876
Cartago	16.1%	17.6%	43.9%	20.4%	2.0%	863
Casanare	19.2%	19.9%	38.8%	20.2%	1.9%	2077
Cauca	16.5%	16.1%	39.8%	25.1%	2.6%	7914
Cesar	19.9%	17.7%	37.2%	23.6%	1.5%	5115
Chocó	17.4%	18.7%	33.4%	29.1%	1.4%	1899
Chía	16.3%	16.4%	51.0%	15.4%	0.9%	1290
Ciénaga	22.5%	19.9%	33.2%	22.7%	1.7%	996
Cundinamarca	17.4%	19.1%	41.5%	19.8%	2.2%	13474
Córdoba	18.7%	17.6%	36.5%	25.5%	1.7%	8801
Cúcuta	18.0%	18.6%	42.6%	19.7%	1.0%	6037
Dosquebradas	16.2%	17.1%	43.9%	21.1%	1.7%	1266
Duitama	18.1%	16.8%	50.9%	12.8%	1.4%	1069
Envigado	20.2%	17.1%	48.2%	13.2%	1.3%	1675
Facatativá	18.2%	16.0%	42.8%	20.8%	2.3%	1064
Florencia	14.6%	18.0%	45.2%	21.0%	1.2%	1285
Floridablanca	18.5%	18.4%	47.2%	14.7%	1.2%	2014
Fusagasugá	19.5%	19.5%	41.7%	18.6%	0.7%	1228
Girardot	17.5%	19.1%	38.8%	23.2%	1.3%	901

Continúa en la siguiente página



ETC/País	A	B	C	D	Omisión y multimarca	N° estudiantes
Girón	17.6%	17.5%	46.1%	16.8%	2.0%	944
Guainía	16.0%	24.7%	26.5%	30.9%	1.9%	162
Guaviare	18.6%	22.3%	36.7%	20.0%	2.4%	575
Huila	16.6%	17.7%	41.6%	22.5%	1.6%	5158
Ibagué	18.3%	18.5%	42.1%	19.4%	1.7%	4329
Ipiales	12.6%	17.8%	49.6%	18.8%	1.2%	1010
Itagüí	22.3%	19.4%	37.0%	18.5%	2.9%	1499
Jamundí	16.6%	16.9%	41.5%	23.4%	1.6%	885
La Guajira	17.2%	18.7%	37.6%	24.9%	1.6%	1790
Lorica	16.6%	17.5%	37.2%	27.6%	1.0%	1169
Magangué	17.0%	15.2%	38.5%	24.4%	4.9%	901
Magdalena	18.8%	17.6%	34.6%	27.1%	1.8%	5175
Maicao	18.7%	18.9%	36.2%	25.0%	1.2%	1131
Malambo	17.6%	16.2%	42.4%	21.9%	1.9%	837
Manizales	18.5%	18.2%	42.5%	20.1%	0.8%	2880
Medellín	19.3%	17.9%	40.5%	20.2%	2.1%	16969
Meta	18.7%	21.6%	37.7%	20.5%	1.5%	3387
Montería	18.5%	17.8%	39.8%	21.9%	2.1%	3977
Mosquera	18.0%	17.8%	46.1%	17.1%	1.1%	1035
Nariño	16.4%	18.0%	41.6%	22.1%	1.9%	5981
Neiva	16.5%	17.5%	43.1%	21.5%	1.4%	3002
Norte de Santander	18.9%	18.4%	39.9%	21.3%	1.5%	4842
Palmira	17.3%	18.0%	43.7%	18.8%	2.3%	2250
Pasto	14.0%	17.3%	46.2%	20.2%	2.2%	3681
Pereira	17.1%	19.5%	43.3%	18.7%	1.3%	3672
Piedecuesta	17.9%	22.8%	40.8%	17.1%	1.4%	1186
Pitalito	17.1%	21.8%	40.2%	19.9%	1.0%	1114
Popayán	16.8%	17.6%	44.5%	19.1%	2.0%	2345
Putumayo	15.1%	19.0%	41.2%	22.4%	2.3%	2503
Quibdó	18.8%	17.9%	37.3%	23.9%	2.2%	1232
Quindío	17.0%	19.2%	40.6%	22.3%	0.9%	2067
Riohacha	18.9%	18.9%	39.2%	21.5%	1.4%	1325
Rionegro	18.4%	20.4%	43.4%	16.4%	1.4%	1074
Risaralda	18.3%	17.9%	40.8%	22.0%	1.0%	1906
Sabaneta	15.8%	13.1%	47.2%	16.8%	7.0%	525
Sahagún	16.9%	19.4%	40.1%	22.6%	1.0%	1089
San Andrés	21.8%	19.2%	38.1%	18.9%	2.0%	449
Santa Marta	20.0%	20.0%	37.3%	20.9%	1.9%	4138
Santander	18.5%	18.9%	42.8%	18.6%	1.2%	6247

Continúa en la siguiente página

ETC/País	A	B	C	D	Omisión y multimarca	N° estudiantes
Sincelejo	16.5%	18.8%	39.3%	24.1%	1.2%	2463
Soacha	19.8%	17.3%	39.1%	22.3%	1.5%	4521
Sogamoso	17.9%	17.7%	46.3%	15.4%	2.7%	1361
Soledad	19.7%	17.9%	39.8%	21.0%	1.6%	3637
Sucre	17.7%	18.8%	35.9%	26.1%	1.5%	5367
Tolima	17.0%	18.7%	39.0%	23.5%	1.7%	6918
Tuluá	17.6%	18.6%	40.6%	22.1%	1.1%	1849
Tumaco	17.1%	18.3%	34.7%	28.3%	1.5%	1327
Tunja	18.1%	17.4%	47.7%	15.1%	1.7%	1487
Turbo	19.2%	20.0%	36.0%	22.0%	2.9%	997
Uribe	17.5%	19.5%	34.6%	27.7%	0.7%	292
Valle del Cauca	17.0%	18.1%	39.7%	22.7%	2.5%	6866
Valledupar	17.5%	17.8%	37.3%	21.6%	5.8%	3938
Vaupés	11.0%	17.5%	39.6%	27.9%	3.9%	154
Vichada	15.6%	20.8%	37.5%	24.2%	1.9%	269
Villavicencio	19.4%	21.2%	40.5%	17.7%	1.3%	3947
Yopal	15.4%	20.3%	45.0%	17.8%	1.4%	1272
Zipaquirá	16.9%	19.3%	48.2%	14.5%	1.1%	1110
Colombia	18.0%	18.3%	41.3%	20.6%	1.9%	366392

*Es posible que los porcentajes mostrados no sumen exactamente 100 debido a aproximaciones decimales.

• **Pregunta 25.**

La gráfica representa las preferencias deportivas de todos los estudiantes de un colegio.

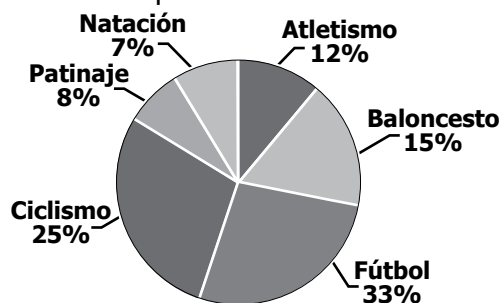

Gráfica

Treinta estudiantes prefieren baloncesto. ¿Cuántos estudiantes hay en el colegio?

- A. 100
- B. 150
- C. 200
- D. 300

• **Estructura**

Competencia	Resolución
Componente	Aleatorio
Afirmación	Resolver y formular problemas a partir de un conjunto de datos presentado en tablas, diagramas de barras y diagrama circular.
Nivel de desempeño	Satisfactorio
Respuesta Correcta	C

• Resultados a nivel nacional y de Entidad Territorial Certificada (ETC)

ETC/País	A	B	C	D	Omisión y multimarca	N° estudiantes
Amazonas	30.4%	22.2%	29.2%	17.1%	1.0%	589
Antioquia	22.3%	22.2%	41.8%	11.0%	2.7%	16848
Apartadó	24.3%	23.9%	36.3%	14.4%	1.1%	1018
Arauca	23.2%	20.5%	45.6%	10.2%	0.5%	1612
Armenia	18.1%	25.0%	46.1%	10.4%	0.4%	2415
Atlántico	27.9%	22.6%	34.6%	13.3%	1.6%	4581
Barrancabermeja	20.8%	25.5%	41.5%	11.0%	1.1%	1899
Barranquilla	21.4%	21.3%	44.8%	11.2%	1.3%	9986
Bello	19.0%	22.2%	46.1%	11.8%	0.9%	3094
Bogotá, D.C.	15.9%	21.5%	53.4%	8.2%	1.0%	60316
Bolívar	29.7%	24.1%	32.9%	11.9%	1.4%	7074
Boyacá	18.9%	21.3%	50.6%	8.3%	0.9%	7298
Bucaramanga	15.3%	19.7%	55.2%	8.5%	1.4%	4683
Buenaventura	34.9%	22.2%	31.1%	10.3%	1.5%	2198
Buga	19.8%	24.4%	45.1%	8.8%	1.9%	886
Caldas	24.3%	22.7%	41.7%	10.6%	0.7%	4246
Cali	20.5%	22.8%	45.2%	9.9%	1.7%	16005
Caquetá	25.7%	22.2%	39.6%	10.5%	2.0%	1584
Cartagena	25.3%	21.4%	39.6%	11.7%	2.0%	8876
Cartago	21.0%	20.6%	43.1%	13.6%	1.7%	863
Casanare	21.3%	22.5%	45.7%	9.1%	1.4%	2077
Cauca	29.3%	20.5%	36.7%	11.6%	1.9%	7914
Cesar	28.5%	22.5%	37.1%	10.7%	1.2%	5115
Chocó	35.5%	22.4%	26.4%	14.5%	1.2%	1899
Chía	13.7%	23.8%	53.4%	8.6%	0.5%	1290
Ciénaga	26.0%	27.6%	30.0%	15.1%	1.3%	996
Cundinamarca	18.6%	21.1%	50.5%	8.3%	1.4%	13474
Córdoba	30.4%	23.2%	31.6%	13.6%	1.2%	8801
Cúcuta	21.9%	17.9%	50.1%	9.6%	0.4%	6037
Dosquebradas	19.0%	21.1%	47.2%	11.8%	0.9%	1266
Duitama	11.3%	17.5%	63.9%	6.7%	0.6%	1069
Envigado	12.1%	21.0%	57.0%	9.6%	0.4%	1675
Facatativá	17.5%	22.1%	51.0%	8.4%	1.0%	1064
Florencia	21.0%	21.1%	48.2%	9.4%	0.2%	1285
Floridablanca	13.9%	20.4%	57.8%	7.3%	0.6%	2014
Fusagasugá	15.7%	22.6%	52.3%	9.2%	0.2%	1228
Girardot	26.5%	22.5%	39.8%	10.2%	0.9%	901

Continúa en la siguiente página



ETC/País	A	B	C	D	Omisión y multimarca	N° estudiantes
Girón	17.7%	21.4%	51.0%	9.0%	1.0%	944
Guainía	29.6%	24.1%	32.7%	12.3%	1.2%	162
Guaviare	23.8%	21.4%	40.2%	12.5%	2.1%	575
Huila	25.0%	20.9%	43.6%	9.5%	1.0%	5158
Ibagué	19.0%	23.4%	47.8%	8.7%	1.1%	4329
Ipiales	20.1%	21.0%	50.6%	7.5%	0.8%	1010
Itagüí	15.8%	25.2%	43.8%	12.7%	2.4%	1499
Jamundí	27.9%	21.8%	40.8%	8.6%	0.9%	885
La Guajira	31.1%	22.3%	33.9%	11.4%	1.3%	1790
Lorica	27.4%	24.9%	33.3%	13.5%	0.9%	1169
Magangué	32.3%	21.5%	31.4%	10.7%	4.1%	901
Magdalena	32.4%	22.3%	31.1%	12.7%	1.5%	5175
Maicao	32.8%	21.4%	32.1%	13.1%	0.6%	1131
Malambo	24.9%	21.4%	41.6%	11.4%	0.8%	837
Manizales	17.7%	22.6%	48.2%	10.6%	0.8%	2880
Medellín	17.8%	23.3%	46.3%	11.1%	1.5%	16969
Meta	23.0%	22.0%	45.7%	8.5%	0.8%	3387
Montería	25.6%	21.9%	39.6%	11.8%	1.2%	3977
Mosquera	15.5%	21.3%	54.4%	8.6%	0.3%	1035
Nariño	26.6%	18.1%	44.7%	9.3%	1.3%	5981
Neiva	23.6%	19.7%	47.9%	8.1%	0.7%	3002
Norte de Santander	23.1%	19.3%	46.9%	9.9%	0.8%	4842
Palmira	20.2%	20.9%	49.3%	8.4%	1.2%	2250
Pasto	21.6%	20.4%	48.8%	7.9%	1.3%	3681
Pereira	17.2%	22.4%	49.6%	9.8%	1.0%	3672
Piedecuesta	18.6%	20.2%	52.5%	8.3%	0.4%	1186
Pitalito	20.4%	19.4%	50.8%	9.2%	0.2%	1114
Popayán	20.5%	21.8%	47.6%	9.0%	1.1%	2345
Putumayo	27.5%	19.3%	42.1%	9.7%	1.5%	2503
Quibdó	27.2%	25.1%	29.8%	16.6%	1.4%	1232
Quindío	22.1%	21.9%	44.8%	10.6%	0.7%	2067
Riohacha	28.0%	22.2%	37.1%	11.7%	1.1%	1325
Rionegro	18.8%	20.4%	50.8%	9.1%	0.8%	1074
Risaralda	23.4%	21.7%	44.0%	10.3%	0.6%	1906
Sabaneta	12.8%	19.0%	51.4%	10.3%	6.5%	525
Sahagún	27.5%	23.6%	36.5%	12.1%	0.2%	1089
San Andrés	26.3%	24.7%	37.2%	9.8%	2.0%	449
Santa Marta	23.2%	23.2%	39.4%	12.9%	1.3%	4138
Santander	19.9%	20.8%	49.4%	9.2%	0.7%	6247

Continúa en la siguiente página

ETC/País	A	B	C	D	Omisión y multimarca	N° estudiantes
Sincelejo	23.7%	23.3%	42.9%	9.5%	0.7%	2463
Soacha	19.8%	22.8%	47.7%	8.7%	1.0%	4521
Sogamoso	15.1%	22.6%	52.1%	7.9%	2.4%	1361
Soledad	23.3%	22.6%	43.2%	9.8%	1.0%	3637
Sucre	29.7%	23.1%	32.1%	14.2%	0.9%	5367
Tolima	27.6%	22.5%	38.6%	10.0%	1.3%	6918
Tuluá	22.7%	23.0%	43.9%	10.1%	0.3%	1849
Tumaco	32.4%	21.4%	28.3%	16.4%	1.6%	1327
Tunja	12.8%	20.2%	56.2%	9.2%	1.5%	1487
Turbo	30.7%	24.4%	29.9%	12.4%	2.6%	997
Uribe	33.2%	22.9%	28.4%	14.0%	1.4%	292
Valle del Cauca	25.5%	22.8%	39.2%	10.6%	1.9%	6866
Valledupar	26.4%	21.9%	36.6%	10.1%	5.0%	3938
Vaupés	32.5%	16.2%	31.2%	16.9%	3.2%	154
Vichada	21.6%	26.0%	38.3%	13.8%	0.4%	269
Villavicencio	19.3%	20.8%	50.6%	8.6%	0.7%	3947
Yopal	18.6%	21.6%	50.2%	8.8%	0.8%	1272
Zipaquirá	16.4%	17.5%	58.3%	7.4%	0.5%	1110
Colombia	21.8%	21.8%	45.0%	10.1%	1.3%	366392

*Es posible que los porcentajes mostrados no sumen exactamente 100 debido a aproximaciones decimales.



- **Pregunta 26.**

Tres estudiantes, E , F y G , juegan un torneo de ajedrez. Cada uno se enfrenta una sola vez con los otros dos. Un jugador obtiene 3 puntos por una victoria, 1 punto por un empate y 0 puntos por una derrota.

Al finalizar el torneo, E obtuvo 2 puntos y F obtuvo 1 punto. ¿Cuántos puntos obtuvo G ?

- A. 1
- B. 2
- C. 3
- D. 4

- **Estructura**

Competencia	Resolución
Componente	Numérico - variacional
Afirmación	Resolver problemas en situaciones aditivas y multiplicativas en el conjunto de los números reales.
Nivel de desempeño	Avanzado
Respuesta Correcta	D

• Resultados a nivel nacional y de Entidad Territorial Certificada (ETC)

ETC/País	A	B	C	D	Omisión y multimarca	N° estudiantes
Amazonas	12.1%	8.7%	42.6%	35.7%	1.0%	589
Antioquia	17.2%	11.1%	33.7%	35.2%	2.8%	16848
Apartadó	19.1%	12.8%	35.6%	31.6%	1.0%	1018
Arauca	17.0%	9.1%	34.2%	39.0%	0.7%	1612
Armenia	16.4%	12.5%	31.7%	38.9%	0.4%	2415
Atlántico	17.8%	11.9%	36.4%	32.2%	1.7%	4581
Barrancabermeja	19.3%	11.6%	32.0%	35.9%	1.2%	1899
Barranquilla	17.9%	11.7%	30.2%	38.7%	1.5%	9986
Bello	18.6%	11.1%	30.8%	38.4%	1.1%	3094
Bogotá, D.C.	16.2%	10.3%	29.6%	42.9%	1.0%	60316
Bolívar	16.8%	12.0%	39.2%	30.4%	1.7%	7074
Boyacá	19.0%	10.9%	32.7%	36.3%	1.0%	7298
Bucaramanga	17.0%	10.0%	28.0%	43.6%	1.4%	4683
Buenaventura	18.4%	9.8%	39.5%	30.7%	1.5%	2198
Buga	17.8%	10.0%	31.8%	38.1%	2.1%	886
Caldas	17.8%	11.6%	35.3%	34.5%	0.8%	4246
Cali	18.3%	11.8%	30.3%	37.8%	1.8%	16005
Caquetá	17.1%	10.5%	36.2%	34.1%	2.1%	1584
Cartagena	18.2%	11.4%	32.1%	36.3%	1.9%	8876
Cartago	16.8%	11.7%	32.9%	37.1%	1.5%	863
Casanare	17.4%	10.8%	34.2%	36.3%	1.3%	2077
Cauca	17.9%	11.6%	38.2%	30.2%	2.0%	7914
Cesar	19.0%	13.1%	36.3%	30.5%	1.2%	5115
Chocó	15.5%	12.5%	41.1%	29.6%	1.3%	1899
Chía	14.5%	9.5%	30.4%	45.1%	0.5%	1290
Ciénaga	21.4%	13.3%	38.0%	25.8%	1.6%	996
Cundinamarca	17.1%	10.2%	33.0%	38.0%	1.6%	13474
Córdoba	17.6%	11.2%	40.6%	29.3%	1.3%	8801
Cúcuta	18.6%	11.1%	31.6%	38.0%	0.7%	6037
Dosquebradas	17.1%	11.8%	32.3%	37.8%	1.0%	1266
Duitama	15.5%	9.7%	31.2%	42.9%	0.6%	1069
Envigado	15.7%	11.4%	26.3%	45.8%	0.8%	1675
Facatativá	18.3%	9.8%	33.5%	37.5%	0.9%	1064
Florencia	21.0%	9.2%	30.3%	39.3%	0.2%	1285
Floridablanca	16.6%	9.8%	26.5%	46.3%	0.8%	2014
Fusagasugá	16.6%	11.2%	31.1%	40.6%	0.4%	1228
Girardot	18.3%	9.9%	38.6%	32.5%	0.7%	901

Continúa en la siguiente página



ETC/País	A	B	C	D	Omisión y multimarca	N° estudiantes
Girón	17.3%	10.9%	28.5%	42.2%	1.2%	944
Guainía	24.1%	6.8%	37.7%	30.2%	1.2%	162
Guaviare	17.6%	12.0%	34.8%	33.6%	2.1%	575
Huila	19.8%	11.7%	34.2%	33.3%	1.0%	5158
Ibagué	18.1%	10.8%	31.5%	38.3%	1.3%	4329
Ipiales	19.5%	13.8%	27.0%	38.9%	0.8%	1010
Itagüí	17.8%	13.5%	32.0%	34.4%	2.3%	1499
Jamundí	20.1%	11.6%	35.3%	32.4%	0.6%	885
La Guajira	16.9%	11.7%	38.2%	31.8%	1.4%	1790
Lorica	15.6%	12.6%	41.1%	29.9%	0.8%	1169
Magangué	19.4%	11.4%	33.5%	31.3%	4.3%	901
Magdalena	18.0%	11.0%	39.7%	29.6%	1.7%	5175
Maicao	18.7%	10.0%	38.7%	31.7%	0.9%	1131
Malambo	18.9%	11.4%	35.0%	33.8%	1.0%	837
Manizales	16.1%	11.6%	31.4%	40.3%	0.7%	2880
Medellín	17.6%	12.1%	30.4%	38.3%	1.6%	16969
Meta	17.6%	11.2%	34.2%	36.1%	0.9%	3387
Montería	17.6%	12.1%	35.3%	34.1%	0.9%	3977
Mosquera	14.2%	9.2%	29.9%	46.4%	0.4%	1035
Nariño	17.7%	11.0%	32.8%	37.1%	1.4%	5981
Neiva	17.2%	12.0%	33.0%	37.1%	0.7%	3002
Norte de Santander	18.5%	10.1%	33.1%	37.4%	1.0%	4842
Palmira	18.6%	12.9%	29.3%	37.9%	1.2%	2250
Pasto	18.0%	11.8%	30.3%	38.8%	1.1%	3681
Pereira	16.2%	11.7%	32.1%	39.0%	1.0%	3672
Piedecuesta	18.8%	10.1%	29.4%	40.9%	0.8%	1186
Pitalito	18.1%	12.8%	32.1%	36.4%	0.4%	1114
Popayán	18.7%	11.0%	30.5%	38.7%	1.1%	2345
Putumayo	18.3%	11.6%	35.0%	33.4%	1.6%	2503
Quibdó	16.6%	12.6%	39.5%	29.5%	1.8%	1232
Quindío	18.3%	12.1%	34.0%	34.7%	0.8%	2067
Riohacha	16.5%	10.7%	37.6%	33.8%	1.4%	1325
Rionegro	17.2%	11.0%	27.3%	43.7%	0.8%	1074
Risaralda	18.4%	10.2%	35.1%	35.5%	0.8%	1906
Sabaneta	15.4%	9.7%	23.6%	45.0%	6.3%	525
Sahagún	17.1%	10.2%	36.6%	35.8%	0.3%	1089
San Andrés	18.0%	13.1%	39.2%	27.8%	1.8%	449
Santa Marta	18.1%	11.6%	35.6%	33.3%	1.5%	4138
Santander	19.0%	9.6%	33.1%	37.5%	0.8%	6247

Continúa en la siguiente página

ETC/País	A	B	C	D	Omisión y multimarca	N° estudiantes
Sincelejo	19.4%	11.5%	32.2%	36.1%	0.8%	2463
Soacha	16.9%	10.5%	32.9%	38.6%	1.0%	4521
Sogamoso	17.6%	10.7%	30.9%	38.6%	2.1%	1361
Soledad	18.8%	11.3%	32.5%	36.3%	1.1%	3637
Sucre	18.2%	11.1%	39.5%	30.2%	1.0%	5367
Tolima	18.2%	10.9%	38.1%	31.3%	1.5%	6918
Tuluá	17.8%	10.2%	33.6%	38.1%	0.3%	1849
Tumaco	17.0%	11.8%	39.5%	30.3%	1.4%	1327
Tunja	16.3%	9.9%	28.4%	43.8%	1.6%	1487
Turbo	16.1%	13.7%	35.9%	30.9%	3.3%	997
Uribe	18.2%	11.0%	44.2%	26.0%	0.7%	292
Valle del Cauca	18.9%	12.2%	34.6%	32.3%	1.9%	6866
Valledupar	17.8%	11.1%	33.3%	32.8%	5.0%	3938
Vaupés	14.9%	9.1%	39.6%	33.1%	3.2%	154
Vichada	15.2%	12.3%	37.5%	33.8%	1.1%	269
Villavicencio	16.8%	12.3%	31.3%	38.6%	0.9%	3947
Yopal	17.5%	10.0%	32.1%	39.9%	0.6%	1272
Zipaquirá	16.6%	10.8%	27.5%	44.6%	0.5%	1110
Colombia	17.5%	11.1%	33.0%	37.0%	1.4%	366392

*Es posible que los porcentajes mostrados no sumen exactamente 100 debido a aproximaciones decimales.

• **Pregunta 27.**

Un profesor califica una prueba de la siguiente forma: por cada respuesta correcta suma 5 puntos, por cada respuesta incorrecta resta 2 puntos y cuando el estudiante no contesta, no suma ni resta puntos. Claudia, Enrique y Omar obtuvieron los resultados que muestra la tabla.

Estudiante	Aciertos	Incorrectas	No contestadas
Claudia	12	8	0
Enrique	10	6	4
Omar	11	5	4

Tabla

Si los puntajes obtenidos por cada estudiante se ordenan, de mayor a menor, el orden es:

- A. Claudia, Enrique y Omar.
- B. Omar, Claudia y Enrique.
- C. Claudia, Omar y Enrique.
- D. Enrique, Omar y Claudia.

• **Estructura**

Competencia	Resolución
Componente	Numérico - variacional
Afirmación	Resolver problemas en situaciones aditivas y multiplicativas en el conjunto de los números reales.
Nivel de desempeño	Avanzado
Respuesta Correcta	B

• Resultados a nivel nacional y de Entidad Territorial Certificada (ETC)

ETC/País	A	B	C	D	Omisión y multimarca	N° estudiantes
Amazonas	32.6%	13.1%	41.8%	11.5%	1.0%	589
Antioquia	22.9%	23.4%	39.8%	11.2%	2.7%	16848
Apartadó	21.6%	25.2%	38.9%	13.6%	0.7%	1018
Arauca	22.0%	24.7%	43.0%	9.7%	0.6%	1612
Armenia	18.7%	30.9%	39.3%	10.4%	0.7%	2415
Atlántico	25.2%	22.5%	37.9%	13.0%	1.4%	4581
Barrancabermeja	21.1%	30.0%	38.7%	9.4%	0.9%	1899
Barranquilla	21.2%	27.9%	39.1%	10.6%	1.2%	9986
Bello	20.2%	29.4%	38.8%	10.7%	1.0%	3094
Bogotá, D.C.	18.5%	34.2%	37.5%	8.9%	0.8%	60316
Bolívar	25.5%	19.6%	40.0%	13.6%	1.2%	7074
Boyacá	22.3%	26.4%	39.3%	11.1%	0.9%	7298
Bucaramanga	17.2%	36.9%	36.4%	8.3%	1.1%	4683
Buenaventura	25.2%	19.4%	40.6%	13.3%	1.5%	2198
Buga	22.1%	28.7%	38.0%	9.1%	2.0%	886
Caldas	22.7%	24.4%	42.1%	10.0%	0.7%	4246
Cali	20.6%	27.5%	40.1%	10.3%	1.5%	16005
Caquetá	27.3%	20.1%	38.9%	11.9%	1.8%	1584
Cartagena	21.3%	26.8%	38.2%	11.8%	1.9%	8876
Cartago	23.1%	22.0%	41.0%	12.4%	1.5%	863
Casanare	21.9%	25.9%	39.1%	12.1%	1.1%	2077
Cauca	26.2%	18.9%	40.7%	12.5%	1.7%	7914
Cesar	24.1%	21.5%	40.4%	13.1%	1.0%	5115
Chocó	27.6%	18.3%	37.7%	14.4%	1.9%	1899
Chía	17.7%	32.7%	38.4%	10.9%	0.3%	1290
Ciénaga	27.2%	17.6%	40.4%	13.7%	1.2%	996
Cundinamarca	19.8%	29.4%	38.9%	10.5%	1.4%	13474
Córdoba	26.7%	19.4%	38.3%	14.3%	1.3%	8801
Cúcuta	18.9%	31.3%	38.4%	11.0%	0.3%	6037
Dosquebradas	19.7%	28.9%	40.7%	9.8%	0.9%	1266
Duitama	14.3%	39.9%	37.0%	8.2%	0.5%	1069
Envigado	16.9%	38.4%	34.7%	9.5%	0.4%	1675
Facatativá	21.5%	28.2%	40.5%	8.8%	0.9%	1064
Florencia	22.5%	25.9%	41.7%	9.7%	0.2%	1285
Floridablanca	15.0%	38.5%	37.0%	8.9%	0.5%	2014
Fusagasugá	20.4%	31.9%	36.8%	10.5%	0.3%	1228
Girardot	22.6%	23.9%	41.2%	12.0%	0.3%	901

Continúa en la siguiente página



ETC/País	A	B	C	D	Omisión y multimarca	N° estudiantes
Girón	17.8%	30.7%	41.0%	9.4%	1.1%	944
Guainía	25.9%	18.5%	38.9%	16.7%	0.0%	162
Guaviare	22.4%	24.9%	37.4%	13.6%	1.7%	575
Huila	23.0%	22.5%	42.8%	10.8%	1.0%	5158
Ibagué	20.7%	27.9%	40.0%	10.4%	1.1%	4329
Ipiales	20.4%	29.4%	39.5%	10.4%	0.3%	1010
Itagüí	19.9%	29.8%	36.0%	12.0%	2.4%	1499
Jamundí	24.4%	23.8%	39.7%	11.9%	0.2%	885
La Guajira	26.3%	21.3%	38.1%	13.1%	1.2%	1790
Lorica	26.3%	20.4%	36.4%	15.7%	1.1%	1169
Magangué	23.5%	21.9%	37.6%	13.0%	4.0%	901
Magdalena	27.8%	18.6%	37.6%	14.3%	1.7%	5175
Maicao	25.4%	21.8%	39.5%	12.4%	0.9%	1131
Malambo	21.9%	24.6%	42.4%	10.0%	1.1%	837
Manizales	21.3%	28.5%	39.7%	10.0%	0.5%	2880
Medellín	19.8%	29.6%	37.7%	11.5%	1.5%	16969
Meta	20.2%	26.8%	40.3%	11.9%	0.8%	3387
Montería	21.6%	25.0%	39.0%	13.4%	0.9%	3977
Mosquera	21.2%	34.6%	35.1%	8.9%	0.3%	1035
Nariño	23.6%	26.1%	39.3%	9.8%	1.2%	5981
Neiva	19.7%	28.9%	40.8%	10.0%	0.6%	3002
Norte de Santander	20.7%	24.8%	43.6%	10.1%	0.8%	4842
Palmira	19.7%	28.8%	39.3%	11.2%	1.0%	2250
Pasto	20.2%	32.0%	38.1%	9.0%	0.8%	3681
Pereira	20.4%	30.2%	39.1%	9.4%	0.9%	3672
Piedecuesta	17.6%	30.7%	42.3%	9.1%	0.3%	1186
Pitalito	21.4%	26.2%	42.2%	10.2%	0.0%	1114
Popayán	19.2%	31.8%	39.3%	9.0%	0.7%	2345
Putumayo	22.7%	25.2%	39.6%	11.3%	1.2%	2503
Quibdó	24.3%	20.0%	40.4%	13.3%	2.0%	1232
Quindío	24.7%	23.1%	38.5%	13.1%	0.6%	2067
Riohacha	25.4%	22.0%	40.2%	11.1%	1.4%	1325
Rionegro	20.9%	30.5%	38.6%	9.2%	0.7%	1074
Risaralda	25.0%	21.8%	41.9%	10.8%	0.6%	1906
Sabaneta	14.3%	32.8%	37.9%	8.2%	6.9%	525
Sahagún	25.3%	20.7%	42.0%	11.9%	0.2%	1089
San Andrés	24.1%	24.1%	33.6%	16.7%	1.6%	449
Santa Marta	24.5%	25.6%	37.7%	10.9%	1.3%	4138
Santander	21.4%	28.1%	40.1%	9.8%	0.6%	6247

Continúa en la siguiente página

ETC/País	A	B	C	D	Omisión y multimarca	N° estudiantes
Sincelejo	22.4%	24.7%	40.9%	11.4%	0.6%	2463
Soacha	20.1%	28.9%	40.2%	9.9%	0.9%	4521
Sogamoso	18.9%	34.6%	34.6%	9.8%	2.1%	1361
Soledad	22.3%	25.5%	39.8%	11.5%	0.9%	3637
Sucre	26.9%	19.3%	39.5%	13.4%	0.9%	5367
Tolima	25.1%	21.7%	39.6%	12.2%	1.4%	6918
Tuluá	22.6%	26.3%	40.6%	10.3%	0.2%	1849
Tumaco	26.0%	16.9%	43.1%	12.8%	1.2%	1327
Tunja	20.3%	34.8%	35.3%	8.1%	1.5%	1487
Turbo	25.6%	15.4%	40.3%	15.7%	2.9%	997
Uribe	30.1%	13.7%	41.8%	14.4%	0.0%	292
Valle del Cauca	23.4%	23.2%	40.2%	11.3%	1.8%	6866
Valledupar	23.1%	23.5%	37.6%	11.1%	4.7%	3938
Vaupés	32.5%	16.9%	35.7%	10.4%	4.5%	154
Vichada	26.0%	20.8%	38.3%	14.1%	0.7%	269
Villavicencio	18.2%	31.5%	39.4%	10.1%	0.8%	3947
Yopal	17.8%	31.8%	40.4%	9.4%	0.6%	1272
Zipaquirá	18.5%	33.7%	39.2%	8.6%	0.1%	1110
Colombia	21.6%	27.3%	39.0%	10.9%	1.2%	366392

*Es posible que los porcentajes mostrados no sumen exactamente 100 debido a aproximaciones decimales.

• **Pregunta 28.**

Los prismas rectangulares que se muestran a continuación tienen igual volumen (80 cm^3) y sus dimensiones son las señaladas en las figuras:



Figura 1



Figura 2

¿Cuál de las siguientes afirmaciones respecto a h y k es correcta?

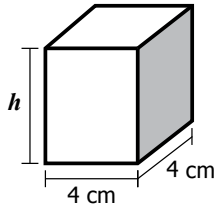
- A. $2h = k$
- B. $4h = k$
- C. $12h = k$
- D. $20h = k$

• **Estructura**

Competencia	Comunicación
Componente	Espacial - métrico
Afirmación	Diferenciar magnitudes de un objeto y relacionar las dimensiones de éste con la determinación de las magnitudes.
Nivel de desempeño	Avanzado
Respuesta Correcta	B

• Resultados a nivel nacional y de Entidad Territorial Certificada (ETC)

ETC/País	A	B	C	D	Omisión y multimarca	N° estudiantes
Amazonas	15.6%	38.9%	30.4%	14.4%	0.7%	589
Antioquia	16.6%	43.6%	26.1%	10.9%	2.7%	16848
Apartadó	18.4%	42.3%	28.8%	9.9%	0.6%	1018
Arauca	14.6%	41.9%	32.6%	10.4%	0.5%	1612
Armenia	17.5%	46.3%	26.7%	8.9%	0.5%	2415
Atlántico	18.8%	43.7%	25.8%	10.3%	1.4%	4581
Barrancabermeja	18.6%	43.5%	26.3%	10.6%	0.9%	1899
Barranquilla	18.4%	44.1%	25.8%	10.3%	1.5%	9986
Bello	18.7%	44.6%	25.7%	10.0%	1.0%	3094
Bogotá, D.C.	16.4%	47.4%	25.3%	9.7%	1.2%	60316
Bolívar	17.2%	40.2%	29.6%	11.4%	1.6%	7074
Boyacá	14.7%	46.9%	27.0%	10.5%	1.0%	7298
Bucaramanga	17.0%	49.5%	22.8%	9.2%	1.5%	4683
Buenaventura	17.7%	40.6%	30.1%	10.1%	1.5%	2198
Buga	18.1%	45.0%	25.3%	9.1%	2.5%	886
Caldas	15.4%	44.9%	28.5%	10.1%	1.0%	4246
Cali	16.8%	45.8%	25.3%	10.3%	1.8%	16005
Caquetá	17.1%	44.1%	24.7%	11.9%	2.1%	1584
Cartagena	18.8%	43.8%	25.6%	9.7%	2.1%	8876
Cartago	16.9%	43.8%	28.6%	9.3%	1.4%	863
Casanare	14.3%	45.3%	28.0%	11.0%	1.4%	2077
Cauca	14.7%	45.0%	27.2%	11.2%	2.0%	7914
Cesar	17.0%	44.3%	25.8%	11.9%	1.0%	5115
Chocó	18.7%	42.6%	26.0%	11.2%	1.5%	1899
Chía	16.3%	48.2%	24.3%	10.2%	0.9%	1290
Ciénaga	19.9%	43.2%	26.3%	9.6%	1.0%	996
Cundinamarca	15.1%	46.0%	27.1%	10.2%	1.6%	13474
Córdoba	18.6%	42.9%	27.2%	10.2%	1.1%	8801
Cúcuta	15.5%	47.9%	25.4%	10.7%	0.5%	6037
Dosquebradas	16.5%	45.4%	27.7%	9.2%	1.1%	1266
Duitama	17.4%	52.0%	22.7%	7.3%	0.6%	1069
Envigado	22.9%	46.6%	21.6%	8.4%	0.5%	1675
Facatativá	15.5%	48.4%	25.1%	9.8%	1.2%	1064
Florencia	15.5%	42.2%	30.6%	11.1%	0.7%	1285
Floridablanca	17.1%	49.2%	24.1%	9.1%	0.5%	2014
Fusagasugá	14.0%	46.4%	27.9%	11.2%	0.5%	1228
Girardot	15.0%	48.3%	27.2%	9.1%	0.4%	901

Continúa en la siguiente página



ETC/País	A	B	C	D	Omisión y multimarca	N° estudiantes
Girón	14.9%	49.8%	24.4%	9.9%	1.1%	944
Guainía	14.8%	40.1%	29.6%	14.2%	1.2%	162
Guaviare	15.3%	44.3%	27.8%	10.1%	2.4%	575
Huila	14.2%	47.0%	27.6%	10.2%	0.9%	5158
Ibagué	17.2%	44.7%	26.4%	10.4%	1.3%	4329
Ipiales	13.5%	47.9%	24.8%	13.1%	0.8%	1010
Itagüí	21.5%	43.6%	23.4%	9.3%	2.2%	1499
Jamundí	16.5%	46.9%	27.3%	8.8%	0.5%	885
La Guajira	17.4%	45.2%	26.4%	10.1%	0.9%	1790
Lorica	19.5%	45.3%	25.8%	8.9%	0.5%	1169
Magangué	14.8%	42.4%	27.9%	10.7%	4.3%	901
Magdalena	18.2%	41.9%	27.3%	11.2%	1.4%	5175
Maicao	18.6%	43.9%	26.8%	10.3%	0.4%	1131
Malambo	16.1%	47.3%	25.1%	10.4%	1.1%	837
Manizales	17.3%	45.9%	26.9%	9.0%	0.9%	2880
Medellín	18.1%	43.8%	26.4%	10.0%	1.7%	16969
Meta	13.9%	44.7%	28.6%	11.9%	0.9%	3387
Montería	18.3%	45.1%	26.1%	9.4%	1.1%	3977
Mosquera	15.4%	48.3%	25.6%	10.2%	0.5%	1035
Nariño	14.5%	45.7%	25.4%	12.9%	1.4%	5981
Neiva	15.6%	48.2%	26.4%	9.0%	0.8%	3002
Norte de Santander	15.2%	47.0%	25.6%	11.3%	0.9%	4842
Palmira	15.3%	47.2%	26.0%	10.4%	1.2%	2250
Pasto	16.8%	49.2%	23.0%	9.9%	1.1%	3681
Pereira	16.4%	45.9%	27.0%	9.7%	1.0%	3672
Piedecuesta	16.4%	46.1%	25.6%	11.3%	0.6%	1186
Pitalito	15.2%	47.3%	25.7%	11.5%	0.4%	1114
Popayán	16.8%	47.0%	23.9%	11.1%	1.2%	2345
Putumayo	14.4%	44.1%	28.6%	11.4%	1.4%	2503
Quibdó	15.5%	37.4%	32.5%	13.1%	1.5%	1232
Quindío	16.4%	42.8%	30.2%	9.9%	0.8%	2067
Riohacha	18.5%	42.0%	27.4%	11.3%	0.8%	1325
Rionegro	18.2%	46.6%	23.8%	10.4%	0.8%	1074
Risaralda	17.0%	45.3%	26.1%	11.1%	0.6%	1906
Sabaneta	15.6%	46.7%	22.3%	8.6%	6.9%	525
Sahagún	17.7%	41.5%	29.5%	11.0%	0.3%	1089
San Andrés	22.3%	39.6%	27.8%	8.7%	1.6%	449
Santa Marta	17.8%	43.8%	26.6%	10.4%	1.4%	4138
Santander	15.8%	47.9%	25.1%	10.6%	0.6%	6247

Continúa en la siguiente página

ETC/País	A	B	C	D	Omisión y multimarca	N° estudiantes
Sincelejo	18.4%	44.1%	26.5%	10.2%	0.8%	2463
Soacha	16.2%	46.6%	26.1%	10.0%	1.1%	4521
Sogamoso	13.9%	52.7%	23.1%	8.2%	2.1%	1361
Soledad	16.5%	46.2%	25.6%	10.5%	1.1%	3637
Sucre	17.0%	41.9%	29.8%	10.4%	1.0%	5367
Tolima	15.2%	43.9%	28.6%	10.8%	1.5%	6918
Tuluá	15.3%	45.2%	29.2%	9.6%	0.8%	1849
Tumaco	16.2%	42.1%	30.0%	10.5%	1.2%	1327
Tunja	17.6%	48.0%	24.7%	8.1%	1.5%	1487
Turbo	15.8%	40.9%	29.0%	11.8%	2.4%	997
Uribe	11.3%	38.0%	40.4%	10.3%	0.0%	292
Valle del Cauca	14.9%	44.0%	29.0%	10.1%	2.1%	6866
Valledupar	18.5%	40.5%	25.9%	10.0%	5.2%	3938
Vaupés	12.3%	41.6%	31.2%	11.0%	3.9%	154
Vichada	15.2%	44.6%	29.4%	10.4%	0.4%	269
Villavicencio	16.5%	46.7%	25.2%	10.9%	0.8%	3947
Yopal	13.4%	46.9%	27.5%	11.0%	1.1%	1272
Zipacquirá	16.5%	50.0%	24.0%	9.3%	0.3%	1110
Colombia	16.6%	45.3%	26.4%	10.3%	1.4%	366392

*Es posible que los porcentajes mostrados no sumen exactamente 100 debido a aproximaciones decimales.

• **Pregunta 29.**

La tabla muestra la información sobre la longitud (en cm) de la sombra de un objeto a diferentes horas del día en un mismo lugar.

Hora del día	Longitud de la sombra (cm)
12:30 p.m.	40
1:00 p.m.	34
1:30 p.m.	30
2:00 p.m.	28
2:30 p.m.	32

Tabla

¿Cuál de las siguientes gráficas describe adecuadamente la información presentada en la tabla?

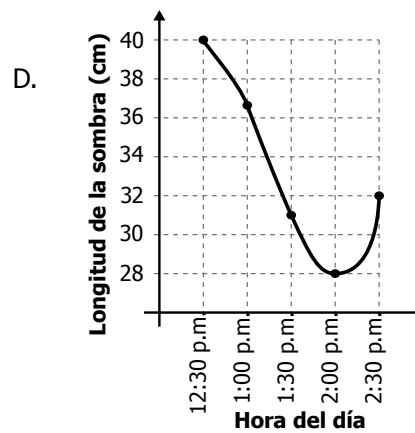
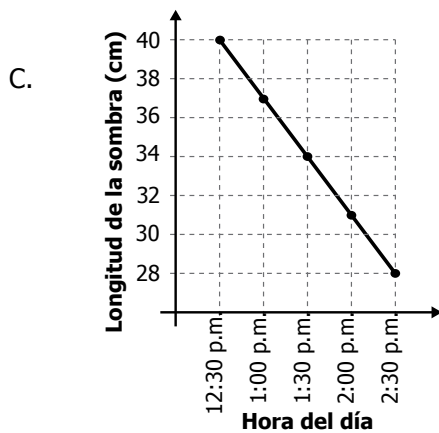
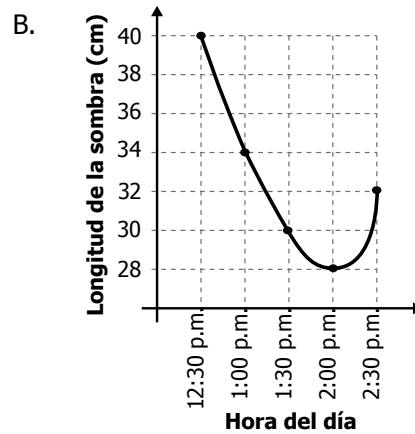
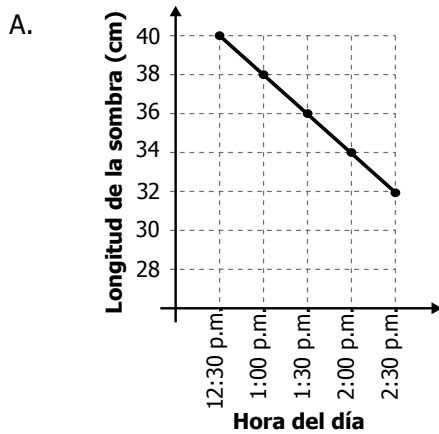

• Estructura

Competencia	Comunicación
Componente	Numérico - variacional
Afirmación	Usar y relacionar diferentes representaciones para modelar situaciones de variación, y viceversa.
Nivel de desempeño	Mínimo
Respuesta Correcta	B

• Resultados a nivel nacional y de Entidad Territorial Certificada (ETC)

ETC/País	A	B	C	D	Omisión y multimarca	N° estudiantes
Amazonas	10.2%	64.9%	16.6%	7.0%	1.4%	589
Antioquia	7.0%	73.5%	10.4%	6.4%	2.7%	16848
Apartadó	10.4%	65.3%	15.2%	8.1%	1.0%	1018
Arauca	5.5%	82.1%	7.9%	4.0%	0.5%	1612
Armenia	6.6%	78.6%	8.7%	5.8%	0.4%	2415
Atlántico	9.9%	66.0%	14.6%	7.8%	1.7%	4581
Barrancabermeja	5.7%	76.8%	10.2%	6.0%	1.3%	1899
Barranquilla	6.4%	77.1%	9.0%	6.2%	1.3%	9986
Bello	7.3%	76.6%	9.0%	6.1%	0.9%	3094
Bogotá, D.C.	3.4%	87.0%	4.9%	3.8%	0.8%	60316
Bolívar	10.4%	63.8%	16.3%	8.0%	1.5%	7074
Boyacá	4.0%	85.3%	5.7%	4.2%	0.8%	7298
Bucaramanga	2.9%	87.3%	5.1%	3.7%	1.1%	4683
Buenaventura	9.3%	65.5%	16.2%	7.6%	1.5%	2198
Buga	5.1%	80.6%	7.1%	5.2%	2.0%	886
Caldas	6.1%	78.8%	8.6%	5.7%	0.7%	4246
Cali	5.5%	79.6%	8.3%	5.2%	1.4%	16005
Caquetá	6.6%	74.6%	10.2%	6.7%	2.0%	1584
Cartagena	8.3%	71.7%	11.5%	6.7%	1.8%	8876
Cartago	5.1%	80.0%	6.6%	6.7%	1.6%	863
Casanare	4.9%	81.8%	6.6%	5.5%	1.3%	2077
Cauca	7.1%	73.8%	11.2%	6.2%	1.7%	7914
Cesar	7.6%	72.2%	12.2%	6.9%	1.1%	5115
Chocó	14.5%	51.5%	22.8%	9.4%	1.8%	1899
Chía	1.6%	90.9%	3.5%	3.4%	0.5%	1290

Continúa en la siguiente página

ETC/País	A	B	C	D	Omisión y multimarca	N° estudiantes
Ciénaga	10.4%	59.7%	17.9%	10.5%	1.4%	996
Cundinamarca	3.8%	85.2%	5.4%	4.2%	1.4%	13474
Córdoba	10.0%	64.3%	16.6%	7.8%	1.3%	8801
Cúcuta	5.1%	82.8%	7.2%	4.6%	0.4%	6037
Dosquebradas	3.7%	84.0%	7.1%	4.2%	1.0%	1266
Duitama	2.4%	91.4%	3.4%	2.3%	0.5%	1069
Envigado	4.5%	82.5%	7.3%	5.4%	0.3%	1675
Facatativá	3.1%	86.5%	5.3%	4.3%	0.8%	1064
Florencia	3.9%	83.5%	6.3%	5.8%	0.5%	1285
Floridablanca	3.6%	87.6%	4.1%	4.2%	0.5%	2014
Fusagasugá	4.3%	87.9%	5.0%	2.5%	0.2%	1228
Girardot	5.8%	75.5%	11.3%	6.8%	0.7%	901
Girón	3.3%	87.5%	4.7%	3.6%	1.0%	944
Guainía	6.8%	77.2%	8.6%	7.4%	0.0%	162
Guaviare	9.0%	69.6%	11.0%	7.8%	2.6%	575
Huila	4.7%	83.7%	7.0%	3.6%	0.9%	5158
Ibagué	4.5%	83.3%	7.0%	4.0%	1.2%	4329
Ipiales	3.4%	87.8%	5.2%	3.1%	0.5%	1010
Itagüí	9.3%	69.4%	11.8%	7.2%	2.2%	1499
Jamundí	6.6%	78.9%	8.6%	5.2%	0.8%	885
La Guajira	8.5%	69.1%	13.6%	7.9%	0.9%	1790
Lorica	11.1%	59.2%	17.9%	10.9%	0.9%	1169
Magangué	10.3%	66.8%	11.5%	7.4%	3.9%	901
Magdalena	11.8%	59.1%	18.7%	8.5%	1.9%	5175
Maicao	10.3%	69.1%	14.0%	6.2%	0.4%	1131
Malambo	8.6%	71.7%	12.1%	6.6%	1.1%	837
Manizales	5.5%	81.8%	7.3%	4.8%	0.6%	2880
Medellín	6.4%	76.2%	9.4%	6.4%	1.5%	16969
Meta	5.2%	80.3%	7.9%	5.7%	0.9%	3387
Montería	6.9%	75.2%	10.6%	6.4%	1.0%	3977
Mosquera	3.6%	88.5%	4.0%	3.6%	0.4%	1035
Nariño	5.1%	81.2%	7.9%	4.6%	1.2%	5981
Neiva	3.7%	87.3%	5.0%	3.5%	0.5%	3002
Norte de Santander	4.6%	81.5%	8.1%	4.9%	0.9%	4842
Palmira	4.8%	82.4%	6.8%	4.8%	1.1%	2250
Pasto	3.1%	86.7%	5.8%	3.7%	0.8%	3681
Pereira	5.2%	81.4%	6.9%	5.7%	0.8%	3672
Piedecuesta	4.9%	84.5%	5.2%	4.8%	0.6%	1186
Pitalito	5.0%	82.1%	6.7%	6.0%	0.1%	1114

Continúa en la siguiente página

GRADO 9° - MATEMÁTICAS

ETC/País	A	B	C	D	Omisión y multimarca	N° estudiantes
Popayán	3.8%	84.3%	6.4%	4.6%	0.8%	2345
Putumayo	5.2%	80.9%	8.1%	4.4%	1.3%	2503
Quibdó	12.9%	57.5%	18.9%	8.9%	1.7%	1232
Quindío	4.8%	79.6%	8.2%	6.5%	0.8%	2067
Riohacha	9.1%	70.3%	13.6%	6.2%	0.8%	1325
Rionegro	4.6%	81.8%	6.9%	6.1%	0.7%	1074
Risaralda	6.5%	79.7%	7.5%	5.8%	0.5%	1906
Sabaneta	3.4%	81.0%	6.5%	2.9%	6.3%	525
Sahagún	8.4%	72.6%	12.4%	6.5%	0.1%	1089
San Andrés	9.8%	62.6%	16.3%	9.6%	1.8%	449
Santa Marta	9.2%	68.1%	12.8%	8.3%	1.6%	4138
Santander	3.8%	85.0%	6.6%	4.0%	0.6%	6247
Sincedejo	5.6%	79.0%	9.5%	5.3%	0.7%	2463
Soacha	4.6%	83.6%	6.0%	4.9%	0.9%	4521
Sogamoso	2.3%	87.3%	4.9%	3.5%	2.0%	1361
Soledad	6.2%	77.2%	10.1%	5.6%	0.9%	3637
Sucre	9.1%	67.0%	15.1%	7.7%	1.1%	5367
Tolima	6.5%	74.9%	10.8%	6.3%	1.4%	6918
Tuluá	6.1%	78.4%	8.3%	6.7%	0.6%	1849
Tumaco	10.2%	61.6%	17.0%	10.1%	1.2%	1327
Tunja	3.0%	88.1%	4.0%	3.5%	1.5%	1487
Turbo	11.8%	58.3%	17.0%	10.0%	2.9%	997
Uribe	8.2%	69.5%	12.7%	9.6%	0.0%	292
Valle del Cauca	6.5%	76.0%	9.6%	6.1%	1.7%	6866
Valledupar	7.1%	72.5%	8.6%	6.7%	5.1%	3938
Vaupés	5.8%	70.1%	16.2%	3.2%	4.5%	154
Vichada	3.7%	77.3%	11.2%	7.1%	0.7%	269
Villavicencio	4.8%	83.2%	6.6%	4.6%	0.8%	3947
Yopal	3.8%	86.7%	4.4%	4.4%	0.7%	1272
Zipaquirá	2.6%	90.1%	3.5%	3.7%	0.1%	1110
Colombia	5.8%	78.6%	8.8%	5.5%	1.2%	366392

*Es posible que los porcentajes mostrados no sumen exactamente 100 debido a aproximaciones decimales.



- **Pregunta 30.**

Con un cordón de 40 cm se mide el largo de una ventana. Se sabe que la ventana tiene entre 2 y 3 m de largo. El largo de la ventana en cordones es

- A. menor que 2.
- B. mayor o igual que 2 y menor que 3.
- C. mayor o igual que 5 y menor que 8.
- D. mayor que 8.

- **Estructura**

Competencia	Comunicación
Componente	Espacial - métrico
Afirmación	Identificar relaciones entre distintas unidades utilizadas para medir cantidades de la misma magnitud y determinar su pertinencia.
Nivel de desempeño	Satisfactorio
Respuesta Correcta	C

• Resultados a nivel nacional y de Entidad Territorial Certificada (ETC)

ETC/País	A	B	C	D	Omisión y multimarca	N° estudiantes
Amazonas	16.3%	33.8%	31.9%	16.6%	1.4%	589
Antioquia	10.1%	30.0%	42.9%	14.0%	3.0%	16848
Apartadó	15.3%	30.5%	40.4%	12.7%	1.2%	1018
Arauca	10.2%	27.9%	47.3%	14.1%	0.4%	1612
Armenia	10.8%	29.9%	45.9%	12.9%	0.5%	2415
Atlántico	13.5%	33.0%	36.6%	15.1%	1.7%	4581
Barrancabermeja	10.1%	30.5%	44.4%	14.0%	1.1%	1899
Barranquilla	13.0%	29.9%	43.6%	11.9%	1.6%	9986
Bello	10.5%	30.2%	45.2%	12.8%	1.3%	3094
Bogotá, D.C.	8.5%	29.0%	51.4%	9.9%	1.1%	60316
Bolívar	13.4%	30.4%	36.7%	17.5%	2.0%	7074
Boyacá	9.1%	26.8%	50.4%	12.6%	1.1%	7298
Bucaramanga	7.8%	28.0%	52.5%	10.1%	1.6%	4683
Buenaventura	13.1%	33.2%	35.9%	15.5%	2.2%	2198
Buga	9.7%	30.8%	45.7%	10.9%	2.8%	886
Caldas	9.9%	29.1%	45.6%	14.5%	0.9%	4246
Cali	10.2%	29.5%	45.9%	12.4%	1.9%	16005
Caquetá	12.9%	28.9%	42.3%	13.7%	2.1%	1584
Cartagena	12.9%	29.0%	41.5%	14.5%	2.2%	8876
Cartago	8.9%	30.1%	44.8%	13.8%	2.3%	863
Casanare	9.9%	28.7%	46.5%	13.5%	1.3%	2077
Cauca	12.3%	29.6%	39.3%	16.5%	2.3%	7914
Cesar	11.4%	29.0%	42.5%	15.6%	1.5%	5115
Chocó	12.1%	33.8%	34.0%	17.5%	2.7%	1899
Chía	8.2%	26.0%	53.4%	11.6%	0.7%	1290
Ciénaga	16.1%	33.7%	32.8%	15.7%	1.7%	996
Cundinamarca	8.2%	27.1%	50.7%	12.3%	1.7%	13474
Córdoba	12.7%	32.8%	36.9%	16.1%	1.4%	8801
Cúcuta	10.9%	28.3%	47.5%	12.9%	0.4%	6037
Dosquebradas	8.1%	28.4%	51.1%	11.1%	1.3%	1266
Duitama	7.1%	24.9%	58.4%	9.3%	0.4%	1069
Envigado	9.4%	28.0%	50.8%	10.9%	0.9%	1675
Facatativá	8.2%	30.7%	48.9%	11.1%	1.1%	1064
Florencia	11.1%	28.3%	47.2%	12.7%	0.7%	1285
Floridablanca	8.2%	25.2%	54.8%	11.2%	0.6%	2014
Fusagasugá	7.7%	27.1%	53.3%	11.6%	0.3%	1228
Girardot	11.4%	28.5%	45.0%	14.2%	0.9%	901

Continúa en la siguiente página



ETC/País	A	B	C	D	Omisión y multimarca	N° estudiantes
Girón	8.3%	25.8%	52.8%	11.9%	1.3%	944
Guainía	14.2%	27.8%	36.4%	20.4%	1.2%	162
Guaviare	11.3%	29.9%	41.6%	14.3%	3.0%	575
Huila	9.8%	28.4%	45.8%	14.9%	1.1%	5158
Ibagué	9.5%	29.5%	47.9%	11.6%	1.4%	4329
Ipiales	9.9%	29.4%	46.8%	12.4%	1.5%	1010
Itagüí	11.7%	28.5%	43.6%	13.7%	2.5%	1499
Jamundí	12.4%	34.2%	40.8%	12.0%	0.6%	885
La Guajira	13.4%	32.5%	37.7%	15.4%	1.0%	1790
Lorica	13.3%	34.6%	35.6%	15.7%	0.9%	1169
Magangué	11.1%	31.0%	38.3%	15.1%	4.6%	901
Magdalena	13.6%	32.3%	35.5%	16.7%	2.0%	5175
Maicao	14.1%	33.9%	36.3%	15.1%	0.6%	1131
Malambo	14.9%	31.2%	39.8%	12.8%	1.3%	837
Manizales	9.9%	29.4%	47.8%	12.3%	0.6%	2880
Medellín	10.1%	28.7%	46.3%	13.0%	1.9%	16969
Meta	9.9%	29.4%	46.0%	13.8%	0.9%	3387
Montería	10.6%	31.0%	43.3%	14.0%	1.1%	3977
Mosquera	7.1%	28.8%	52.5%	11.4%	0.2%	1035
Nariño	10.9%	28.5%	44.4%	14.6%	1.6%	5981
Neiva	11.0%	27.3%	48.4%	12.6%	0.7%	3002
Norte de Santander	10.6%	26.6%	47.1%	14.7%	1.0%	4842
Palmira	9.1%	29.6%	48.0%	11.9%	1.4%	2250
Pasto	10.8%	28.0%	47.4%	12.7%	1.0%	3681
Pereira	9.8%	29.1%	47.2%	13.0%	0.9%	3672
Piedecuesta	8.4%	26.8%	52.5%	11.4%	0.8%	1186
Pitalito	11.8%	26.3%	48.7%	12.9%	0.3%	1114
Popayán	9.6%	27.3%	49.8%	12.0%	1.2%	2345
Putumayo	11.3%	29.0%	43.8%	14.4%	1.5%	2503
Quibdó	14.6%	31.4%	35.7%	16.3%	1.9%	1232
Quindío	10.3%	30.5%	43.9%	14.5%	0.8%	2067
Riohacha	13.8%	30.8%	40.5%	14.0%	1.0%	1325
Rionegro	8.3%	26.6%	52.2%	11.8%	1.0%	1074
Risaralda	10.5%	30.7%	43.2%	15.1%	0.5%	1906
Sabaneta	6.5%	25.3%	52.4%	9.1%	6.7%	525
Sahagún	12.2%	32.0%	40.0%	15.4%	0.4%	1089
San Andrés	14.9%	31.8%	35.4%	15.4%	2.4%	449
Santa Marta	12.7%	31.8%	40.7%	13.0%	1.7%	4138
Santander	9.7%	27.1%	49.3%	13.1%	0.7%	6247

Continúa en la siguiente página

ETC/País	A	B	C	D	Omisión y multimarca	N° estudiantes
Sincelejo	13.0%	29.1%	43.8%	13.2%	0.9%	2463
Soacha	10.0%	30.2%	45.5%	13.2%	1.2%	4521
Sogamoso	9.8%	25.9%	51.4%	10.7%	2.1%	1361
Soledad	12.9%	31.4%	41.6%	13.0%	1.0%	3637
Sucre	12.9%	32.1%	38.0%	16.1%	1.0%	5367
Tolima	11.2%	30.6%	42.7%	13.9%	1.5%	6918
Tuluá	10.5%	29.9%	45.2%	13.5%	0.9%	1849
Tumaco	13.8%	31.1%	36.2%	17.0%	1.9%	1327
Tunja	7.9%	26.1%	55.0%	9.5%	1.5%	1487
Turbo	15.0%	33.4%	31.9%	16.5%	3.1%	997
Uribe	18.5%	27.7%	35.3%	18.2%	0.3%	292
Valle del Cauca	11.1%	31.1%	41.8%	14.0%	1.9%	6866
Valledupar	12.7%	29.7%	37.5%	15.0%	5.1%	3938
Vaupés	14.9%	26.0%	39.6%	15.6%	3.9%	154
Vichada	12.6%	27.1%	45.4%	14.1%	0.7%	269
Villavicencio	10.0%	26.9%	50.4%	11.8%	0.9%	3947
Yopal	9.2%	25.5%	51.9%	12.4%	1.0%	1272
Zipaquirá	8.7%	27.0%	54.0%	10.2%	0.1%	1110
Colombia	10.5%	29.4%	45.6%	13.1%	1.5%	366392

*Es posible que los porcentajes mostrados no sumen exactamente 100 debido a aproximaciones decimales.

• **Pregunta 31.**

La siguiente gráfica representa la distribución de las acciones de una empresa entre sus socios.

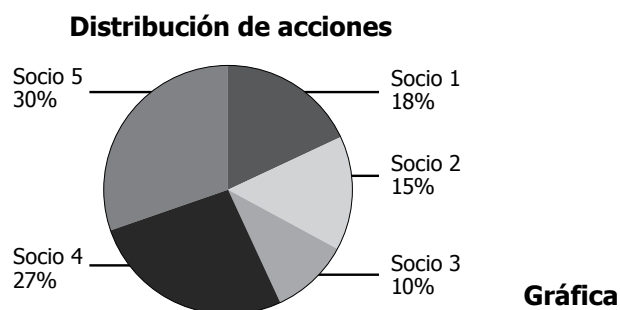

Ciento treinta y dos acciones de la compañía pertenecen a los socios 1 y 2. ¿Cuántas acciones tiene el socio 5?

- A. 30
- B. 120
- C. 165
- D. 280

• **Estructura**

Competencia	Resolución
Componente	Aleatorio
Afirmación	Resolver y formular problemas a partir de un conjunto de datos presentado en tablas, diagramas de barras y diagrama circular.
Nivel de desempeño	Satisfactorio
Respuesta Correcta	B

• Resultados a nivel nacional y de Entidad Territorial Certificada (ETC)

ETC/País	A	B	C	D	Omisión y multimarca	N° estudiantes
Amazonas	31.6%	30.6%	21.2%	13.9%	2.7%	589
Antioquia	22.6%	40.0%	21.7%	12.7%	3.0%	16848
Apartadó	26.9%	34.5%	23.0%	14.2%	1.4%	1018
Arauca	22.5%	41.3%	22.5%	13.2%	0.5%	1612
Armenia	18.7%	43.9%	23.5%	13.3%	0.6%	2415
Atlántico	30.2%	33.3%	19.6%	15.1%	1.8%	4581
Barrancabermeja	19.2%	43.6%	21.5%	14.3%	1.4%	1899
Barranquilla	19.5%	41.8%	21.7%	15.4%	1.6%	9986
Bello	17.2%	43.4%	23.4%	14.9%	1.1%	3094
Bogotá, D.C.	15.1%	48.2%	22.6%	13.0%	1.2%	60316
Bolívar	29.2%	34.2%	20.4%	14.3%	1.8%	7074
Boyacá	19.6%	46.5%	21.5%	11.2%	1.2%	7298
Bucaramanga	14.3%	52.0%	20.5%	11.8%	1.4%	4683
Buenaventura	31.8%	33.9%	18.7%	14.0%	1.6%	2198
Buga	17.6%	43.2%	23.8%	13.1%	2.3%	886
Caldas	24.4%	39.9%	21.2%	13.7%	0.8%	4246
Cali	19.2%	42.7%	22.0%	14.2%	1.9%	16005
Caquetá	26.4%	38.3%	21.4%	11.6%	2.3%	1584
Cartagena	22.5%	38.0%	21.6%	15.6%	2.3%	8876
Cartago	22.6%	39.7%	21.6%	14.1%	2.0%	863
Casanare	22.4%	42.8%	21.4%	11.8%	1.6%	2077
Cauca	30.1%	35.3%	19.5%	12.8%	2.3%	7914
Cesar	27.2%	37.7%	19.6%	14.0%	1.5%	5115
Chocó	37.2%	27.9%	19.9%	13.0%	2.1%	1899
Chía	12.3%	49.5%	23.7%	13.8%	0.6%	1290
Ciénaga	32.4%	32.1%	20.9%	13.0%	1.6%	996
Cundinamarca	17.9%	45.8%	22.5%	12.1%	1.6%	13474
Córdoba	32.3%	32.4%	20.8%	13.1%	1.5%	8801
Cúcuta	20.5%	44.2%	21.0%	13.8%	0.5%	6037
Dosquebradas	17.8%	42.8%	23.1%	15.1%	1.2%	1266
Duitama	11.9%	56.4%	21.1%	10.0%	0.6%	1069
Envigado	13.1%	51.9%	20.7%	13.6%	0.7%	1675
Facatativá	14.5%	46.2%	24.1%	14.2%	1.0%	1064
Florencia	21.2%	43.0%	20.9%	14.3%	0.5%	1285
Floridablanca	13.4%	51.8%	20.0%	13.8%	1.0%	2014
Fusagasugá	16.6%	47.8%	23.1%	12.1%	0.3%	1228
Girardot	28.0%	37.0%	19.5%	14.8%	0.8%	901

Continúa en la siguiente página



ETC/País	A	B	C	D	Omisión y multimarca	N° estudiantes
Girón	13.8%	50.0%	23.0%	11.8%	1.5%	944
Guainía	30.2%	27.8%	27.8%	13.6%	0.6%	162
Guaviare	26.1%	35.7%	21.2%	14.6%	2.4%	575
Huila	23.9%	40.2%	22.1%	12.6%	1.1%	5158
Ibagué	18.9%	44.1%	22.2%	13.4%	1.4%	4329
Ipiales	19.1%	44.3%	22.6%	12.9%	1.2%	1010
Itagüí	17.8%	40.1%	24.5%	15.2%	2.3%	1499
Jamundí	23.1%	41.8%	19.1%	14.9%	1.1%	885
La Guajira	30.2%	33.0%	20.7%	15.0%	1.2%	1790
Lorica	33.6%	29.6%	20.0%	15.1%	1.7%	1169
Magangué	28.9%	30.6%	21.8%	14.4%	4.3%	901
Magdalena	33.2%	30.4%	19.4%	15.1%	1.9%	5175
Maicao	31.6%	33.7%	20.3%	14.0%	0.4%	1131
Malambo	26.6%	40.6%	19.0%	12.4%	1.3%	837
Manizales	18.4%	43.0%	22.3%	15.5%	0.9%	2880
Medellín	17.7%	43.4%	22.5%	14.5%	1.9%	16969
Meta	21.9%	41.8%	22.6%	12.6%	1.0%	3387
Montería	24.6%	38.6%	21.1%	14.2%	1.6%	3977
Mosquera	15.3%	46.5%	24.6%	13.0%	0.6%	1035
Nariño	24.7%	41.6%	19.1%	12.8%	1.8%	5981
Neiva	20.0%	43.1%	22.7%	13.3%	0.9%	3002
Norte de Santander	20.9%	42.6%	22.0%	13.5%	1.1%	4842
Palmira	15.7%	46.7%	21.9%	13.8%	1.9%	2250
Pasto	18.0%	45.6%	22.0%	13.3%	1.1%	3681
Pereira	16.9%	44.6%	22.9%	14.7%	1.0%	3672
Piedecuesta	15.6%	50.2%	21.0%	12.6%	0.7%	1186
Pitalito	17.1%	45.9%	24.1%	12.8%	0.1%	1114
Popayán	18.4%	46.0%	22.3%	12.1%	1.2%	2345
Putumayo	24.1%	41.1%	20.1%	13.0%	1.7%	2503
Quibdó	27.3%	30.6%	23.7%	16.6%	1.8%	1232
Quindío	22.2%	41.1%	22.9%	13.0%	0.8%	2067
Riohacha	26.6%	35.0%	21.6%	15.2%	1.7%	1325
Rionegro	14.2%	51.7%	19.6%	13.5%	1.0%	1074
Risaralda	23.8%	39.7%	22.4%	13.6%	0.5%	1906
Sabaneta	11.4%	46.5%	21.0%	14.1%	7.0%	525
Sahagún	27.9%	35.3%	22.3%	14.0%	0.6%	1089
San Andrés	26.5%	34.3%	20.3%	16.7%	2.2%	449
Santa Marta	22.9%	37.5%	21.4%	16.4%	1.8%	4138
Santander	20.0%	47.0%	20.9%	11.3%	0.8%	6247

Continúa en la siguiente página

ETC/País	A	B	C	D	Omisión y multimarca	N° estudiantes
Sincelejo	23.7%	38.5%	21.8%	15.0%	1.0%	2463
Soacha	18.7%	43.4%	23.2%	13.7%	1.1%	4521
Sogamoso	14.5%	51.7%	21.2%	10.6%	2.0%	1361
Soledad	21.6%	38.7%	22.5%	15.9%	1.3%	3637
Sucre	30.1%	33.2%	21.8%	13.6%	1.3%	5367
Tolima	27.3%	36.7%	20.9%	13.3%	1.7%	6918
Tuluá	22.0%	41.2%	21.6%	14.2%	1.1%	1849
Tumaco	33.5%	31.4%	19.7%	14.0%	1.4%	1327
Tunja	13.8%	48.9%	23.6%	12.1%	1.6%	1487
Turbo	30.5%	30.9%	20.1%	15.0%	3.5%	997
Uribe	39.0%	24.7%	21.2%	14.4%	0.7%	292
Valle del Cauca	24.3%	38.1%	21.5%	13.8%	2.3%	6866
Valledupar	23.5%	37.0%	20.2%	13.9%	5.4%	3938
Vaupés	31.2%	31.2%	15.6%	16.9%	5.2%	154
Vichada	21.9%	38.7%	23.8%	14.9%	0.7%	269
Villavicencio	17.0%	45.9%	22.4%	13.8%	0.9%	3947
Yopal	15.2%	50.4%	21.3%	12.0%	1.1%	1272
Zipaquirá	12.3%	49.9%	24.6%	12.9%	0.3%	1110
Colombia	21.1%	42.1%	21.7%	13.5%	1.6%	366392

*Es posible que los porcentajes mostrados no sumen exactamente 100 debido a aproximaciones decimales.



- **Pregunta 32.**

El cuadrado 1 tiene 8 unidades de perímetro. La medida del lado de un cuadrado cuyo perímetro es la mitad del perímetro del cuadrado 1 es

- A. la mitad de la medida del lado del cuadrado 1.
- B. el doble de la medida del lado del cuadrado 1.
- C. la cuarta parte de la medida del lado del cuadrado 1.
- D. el cuádruplo de la medida del lado del cuadrado 1.

- **Estructura**

Competencia	Razonamiento
Componente	Numérico - variacional
Afirmación	Interpretar y usar expresiones algebraicas equivalentes.
Nivel de desempeño	Avanzado
Respuesta Correcta	A

• Resultados a nivel nacional y de Entidad Territorial Certificada (ETC)

ETC/País	A	B	C	D	Omisión y multimarca	N° estudiantes
Amazonas	35.7%	22.8%	25.3%	14.6%	1.7%	589
Antioquia	36.9%	20.9%	27.0%	12.1%	3.1%	16848
Apartadó	34.0%	24.1%	27.4%	13.3%	1.3%	1018
Arauca	38.2%	21.1%	26.4%	13.2%	1.1%	1612
Armenia	41.4%	20.5%	24.4%	13.0%	0.7%	2415
Atlántico	35.9%	22.1%	26.3%	13.5%	2.2%	4581
Barrancabermeja	39.7%	22.1%	26.3%	10.3%	1.6%	1899
Barranquilla	40.9%	20.5%	25.2%	11.6%	1.8%	9986
Bello	41.0%	20.2%	25.9%	11.4%	1.5%	3094
Bogotá, D.C.	45.0%	19.2%	24.5%	9.8%	1.6%	60316
Bolívar	33.6%	21.9%	28.0%	14.7%	1.9%	7074
Boyacá	42.5%	20.4%	24.7%	11.4%	1.1%	7298
Bucaramanga	45.6%	18.8%	24.3%	9.7%	1.6%	4683
Buenaventura	35.4%	23.1%	26.8%	12.5%	2.2%	2198
Buga	44.7%	18.1%	25.4%	8.8%	3.0%	886
Caldas	38.5%	22.0%	25.7%	12.8%	1.1%	4246
Cali	41.3%	20.1%	25.4%	10.9%	2.3%	16005
Caquetá	38.8%	20.5%	25.9%	12.8%	2.1%	1584
Cartagena	37.7%	20.9%	26.3%	12.7%	2.4%	8876
Cartago	37.9%	20.6%	29.3%	10.0%	2.2%	863
Casanare	38.5%	20.7%	28.4%	11.0%	1.5%	2077
Cauca	36.1%	22.0%	27.2%	12.4%	2.3%	7914
Cesar	35.0%	22.6%	28.0%	12.9%	1.4%	5115
Chocó	34.3%	22.7%	25.3%	15.9%	1.8%	1899
Chía	45.6%	20.4%	24.3%	8.4%	1.2%	1290
Ciénaga	32.9%	19.6%	26.6%	18.6%	2.3%	996
Cundinamarca	41.2%	20.7%	25.9%	10.3%	2.0%	13474
Córdoba	34.2%	23.2%	27.4%	13.7%	1.5%	8801
Cúcuta	41.8%	21.1%	26.5%	9.9%	0.8%	6037
Dosquebradas	41.4%	21.4%	23.4%	11.8%	2.1%	1266
Duitama	48.3%	18.6%	24.1%	7.9%	1.1%	1069
Envigado	42.4%	19.6%	25.0%	11.6%	1.3%	1675
Facatativá	41.4%	23.5%	24.2%	9.4%	1.6%	1064
Florencia	41.5%	21.2%	26.6%	10.0%	0.7%	1285
Floridablanca	47.1%	17.0%	24.8%	9.9%	1.3%	2014
Fusagasugá	42.3%	19.0%	26.7%	10.7%	1.2%	1228
Girardot	37.7%	21.5%	27.0%	12.8%	1.0%	901

Continúa en la siguiente página



ETC/País	A	B	C	D	Omisión y multimarca	N° estudiantes
Girón	42.5%	21.0%	22.6%	12.1%	1.9%	944
Guainía	40.7%	24.1%	24.1%	9.3%	1.9%	162
Guaviare	33.6%	23.0%	25.7%	14.4%	3.3%	575
Huila	39.6%	21.8%	26.9%	10.5%	1.3%	5158
Ibagué	41.8%	19.9%	25.9%	10.9%	1.5%	4329
Ipiales	45.1%	18.5%	24.3%	11.0%	1.1%	1010
Itagüí	37.1%	20.7%	24.2%	15.5%	2.5%	1499
Jamundí	37.5%	20.9%	29.8%	10.1%	1.7%	885
La Guajira	36.1%	23.2%	26.3%	13.2%	1.2%	1790
Lorica	33.5%	22.2%	28.3%	14.8%	1.1%	1169
Magangué	35.4%	20.6%	27.3%	12.1%	4.6%	901
Magdalena	33.9%	22.7%	26.9%	14.7%	1.8%	5175
Maicao	35.1%	19.5%	30.0%	14.7%	0.8%	1131
Malambo	38.9%	22.5%	26.6%	10.5%	1.4%	837
Manizales	41.0%	19.8%	27.7%	10.4%	1.1%	2880
Medellín	38.4%	20.7%	26.0%	12.8%	2.1%	16969
Meta	39.5%	21.8%	25.4%	11.9%	1.4%	3387
Montería	38.5%	20.2%	28.5%	11.2%	1.7%	3977
Mosquera	46.1%	21.1%	23.0%	8.9%	1.0%	1035
Nariño	39.9%	20.4%	27.1%	10.7%	2.0%	5981
Neiva	42.2%	20.4%	26.1%	10.1%	1.3%	3002
Norte de Santander	38.7%	20.7%	26.2%	12.9%	1.4%	4842
Palmira	42.5%	20.6%	24.9%	10.1%	1.9%	2250
Pasto	45.5%	19.7%	24.8%	8.6%	1.4%	3681
Pereira	42.0%	20.8%	25.1%	10.9%	1.1%	3672
Piedecuesta	43.6%	17.7%	24.6%	13.4%	0.7%	1186
Pitalito	42.7%	20.6%	23.7%	12.0%	1.0%	1114
Popayán	42.6%	20.8%	25.7%	9.0%	2.0%	2345
Putumayo	38.2%	20.1%	28.9%	10.7%	2.0%	2503
Quibdó	31.9%	23.1%	28.0%	15.0%	2.0%	1232
Quindío	38.0%	20.8%	27.3%	12.5%	1.4%	2067
Riohacha	36.8%	21.7%	26.6%	13.5%	1.4%	1325
Rionegro	46.5%	19.4%	23.8%	9.0%	1.3%	1074
Risaralda	38.6%	22.7%	26.8%	11.2%	0.7%	1906
Sabaneta	42.1%	19.0%	22.1%	9.9%	6.9%	525
Sahagún	35.6%	21.9%	28.8%	12.8%	0.8%	1089
San Andrés	32.5%	23.4%	26.3%	16.0%	1.8%	449
Santa Marta	36.1%	22.4%	25.6%	13.9%	2.1%	4138
Santander	42.4%	20.3%	25.3%	10.8%	1.1%	6247

Continúa en la siguiente página

ETC/País	A	B	C	D	Omisión y multimarca	N° estudiantes
Sincelejo	36.6%	22.0%	28.2%	12.1%	1.1%	2463
Soacha	41.0%	21.7%	25.9%	10.0%	1.5%	4521
Sogamoso	45.9%	18.8%	24.2%	8.5%	2.6%	1361
Soledad	40.0%	22.2%	23.7%	12.2%	1.8%	3637
Sucre	36.7%	22.3%	26.7%	13.0%	1.3%	5367
Tolima	37.1%	22.7%	25.5%	12.9%	1.7%	6918
Tuluá	39.5%	21.2%	27.3%	10.8%	1.3%	1849
Tumaco	34.1%	20.8%	27.4%	16.3%	1.4%	1327
Tunja	44.6%	19.8%	23.5%	10.4%	1.6%	1487
Turbo	33.7%	21.1%	27.1%	15.3%	2.8%	997
Uribe	31.8%	26.0%	26.4%	15.1%	0.7%	292
Valle del Cauca	37.2%	21.9%	26.5%	12.0%	2.5%	6866
Vалledupar	36.4%	21.9%	24.5%	11.5%	5.6%	3938
Vaupés	37.0%	16.9%	32.5%	9.1%	4.5%	154
Vichada	34.2%	27.9%	24.5%	12.3%	1.1%	269
Villavicencio	43.8%	20.7%	24.4%	9.9%	1.2%	3947
Yopal	39.4%	21.9%	26.8%	10.4%	1.6%	1272
Zipacuirá	46.8%	18.5%	25.5%	8.9%	0.3%	1110
Colombia	40.1%	20.8%	25.9%	11.5%	1.8%	366392

*Es posible que los porcentajes mostrados no sumen exactamente 100 debido a aproximaciones decimales.

• **Pregunta 33.**

La figura representa dos generaciones del árbol genealógico de Daniel.

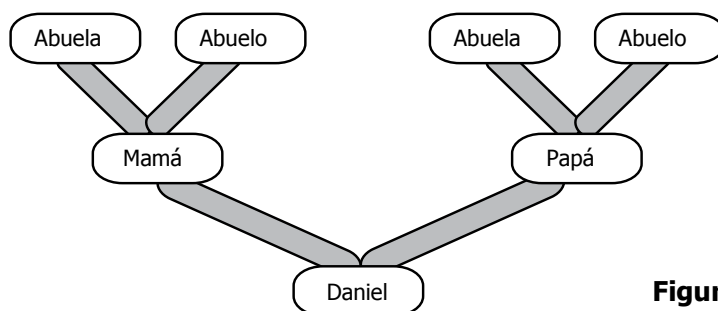

Figura

Los padres de Daniel corresponden a la primera generación, sus abuelos a la segunda, y así sucesivamente ¿Cuál es el número total de ancestros de Daniel de las 3 primeras generaciones?

- A. 6
- B. 7
- C. 14
- D. 15

• **Estructura**

Competencia	Comunicación
Componente	Numérico - variacional
Afirmación	Reconocer reglas de formación de términos en una sucesión, a partir del anterior (adición y producto).
Nivel de desempeño	Avanzado
Respuesta Correcta	C

• Resultados a nivel nacional y de Entidad Territorial Certificada (ETC)

ETC/País	A	B	C	D	Omisión y multimarca	N° estudiantes
Amazonas	53.3%	25.0%	14.3%	6.6%	0.8%	589
Antioquia	43.1%	20.4%	27.7%	6.3%	2.6%	16848
Apartadó	46.0%	23.6%	23.8%	6.0%	0.7%	1018
Arauca	40.8%	21.7%	29.9%	7.3%	0.3%	1612
Armenia	39.1%	18.8%	34.8%	7.0%	0.4%	2415
Atlántico	45.4%	24.4%	22.1%	6.4%	1.6%	4581
Barrancabermeja	40.9%	21.0%	30.4%	6.8%	0.8%	1899
Barranquilla	40.8%	19.5%	31.8%	6.6%	1.3%	9986
Bello	40.2%	18.8%	33.1%	6.9%	0.9%	3094
Bogotá, D.C.	32.8%	15.8%	43.2%	7.2%	0.9%	60316
Bolívar	47.5%	26.8%	17.7%	6.6%	1.5%	7074
Boyacá	36.7%	19.7%	36.0%	6.7%	0.9%	7298
Bucaramanga	32.6%	14.8%	44.2%	7.3%	1.2%	4683
Buenaventura	51.9%	22.2%	17.8%	6.8%	1.3%	2198
Buga	43.8%	17.7%	31.0%	5.0%	2.5%	886
Caldas	44.0%	22.4%	26.9%	5.9%	0.8%	4246
Cali	41.2%	17.9%	32.9%	6.4%	1.6%	16005
Caquetá	47.4%	22.9%	23.2%	4.4%	2.1%	1584
Cartagena	43.2%	20.6%	27.7%	6.6%	1.8%	8876
Cartago	38.2%	21.1%	32.0%	7.1%	1.6%	863
Casanare	41.4%	21.3%	29.3%	6.8%	1.2%	2077
Cauca	47.8%	22.8%	22.5%	5.2%	1.7%	7914
Cesar	48.7%	24.4%	20.8%	5.1%	1.0%	5115
Chocó	51.4%	23.6%	15.6%	8.0%	1.3%	1899
Chía	30.3%	15.0%	46.1%	7.8%	0.8%	1290
Ciénaga	47.2%	25.6%	19.2%	6.9%	1.1%	996
Cundinamarca	36.5%	18.4%	37.1%	6.5%	1.5%	13474
Córdoba	49.3%	24.7%	19.5%	5.6%	1.0%	8801
Cúcuta	39.7%	19.7%	33.7%	6.6%	0.3%	6037
Dosquebradas	39.3%	16.7%	37.9%	5.0%	1.0%	1266
Duitama	27.9%	13.8%	50.3%	7.6%	0.5%	1069
Envigado	31.0%	14.0%	47.5%	7.0%	0.4%	1675
Facatativá	34.9%	16.8%	41.4%	5.9%	0.9%	1064
Florencia	42.5%	19.5%	30.4%	7.4%	0.2%	1285
Floridablanca	32.9%	16.1%	43.5%	7.0%	0.4%	2014
Fusagasugá	35.0%	17.3%	38.9%	8.2%	0.5%	1228
Girardot	43.5%	25.0%	27.3%	3.8%	0.4%	901

Continúa en la siguiente página

ETC/País	A	B	C	D	Omisión y multimarca	N° estudiantes
Girón	37.7%	17.2%	37.8%	6.5%	0.8%	944
Guainía	60.5%	18.5%	15.4%	4.9%	0.6%	162
Guaviare	43.8%	26.6%	22.6%	4.5%	2.4%	575
Huila	43.5%	21.5%	28.5%	5.4%	1.0%	5158
Ibagué	39.2%	18.3%	34.3%	7.0%	1.2%	4329
Ipiales	32.7%	16.7%	42.9%	7.1%	0.6%	1010
Itagüí	40.9%	15.9%	32.3%	8.5%	2.5%	1499
Jamundí	46.6%	20.6%	25.9%	6.4%	0.6%	885
La Guajira	48.1%	24.8%	20.0%	6.0%	1.1%	1790
Lorica	46.4%	26.3%	18.8%	8.0%	0.5%	1169
Magangué	45.1%	23.2%	22.2%	5.3%	4.2%	901
Magdalena	49.5%	27.1%	16.7%	5.1%	1.5%	5175
Maicao	50.4%	23.3%	18.9%	7.1%	0.4%	1131
Malambo	42.2%	25.7%	26.2%	5.1%	0.8%	837
Manizales	40.6%	18.3%	34.3%	6.0%	0.7%	2880
Medellín	38.7%	18.1%	34.4%	7.4%	1.6%	16969
Meta	42.6%	22.6%	27.4%	6.5%	0.8%	3387
Montería	44.7%	21.4%	27.5%	5.6%	0.8%	3977
Mosquera	30.1%	17.6%	43.4%	8.5%	0.4%	1035
Nariño	42.4%	20.4%	29.1%	6.9%	1.2%	5981
Neiva	39.9%	19.8%	33.8%	5.9%	0.5%	3002
Norte de Santander	41.9%	21.5%	29.4%	6.4%	0.8%	4842
Palmira	38.7%	18.8%	34.8%	6.5%	1.1%	2250
Pasto	35.5%	17.2%	39.3%	7.1%	0.9%	3681
Pereira	39.6%	18.1%	35.7%	5.8%	0.8%	3672
Piedecuesta	35.5%	19.1%	40.1%	5.1%	0.2%	1186
Pitalito	38.0%	19.6%	35.5%	6.8%	0.2%	1114
Popayán	37.5%	18.0%	36.7%	6.9%	1.0%	2345
Putumayo	43.7%	21.4%	28.0%	5.4%	1.4%	2503
Quibdó	46.0%	23.0%	19.8%	9.7%	1.5%	1232
Quindío	43.8%	20.4%	28.6%	6.6%	0.6%	2067
Riohacha	47.8%	22.0%	24.1%	4.7%	1.4%	1325
Rionegro	36.5%	16.4%	40.1%	6.2%	0.7%	1074
Risaralda	45.9%	20.7%	26.5%	6.3%	0.5%	1906
Sabaneta	31.8%	12.0%	43.8%	5.9%	6.5%	525
Sahagún	46.1%	22.1%	24.6%	6.5%	0.6%	1089
San Andrés	49.2%	20.7%	22.5%	5.8%	1.8%	449
Santa Marta	44.6%	22.1%	25.4%	6.7%	1.1%	4138
Santander	38.7%	19.3%	34.8%	6.5%	0.6%	6247

Continúa en la siguiente página

ETC/País	A	B	C	D	Omisión y multimarca	N° estudiantes
Sincelejo	44.1%	20.2%	28.5%	6.5%	0.7%	2463
Soacha	38.3%	19.3%	35.1%	6.4%	0.9%	4521
Sogamoso	33.5%	17.0%	41.7%	5.7%	2.1%	1361
Soledad	42.4%	21.8%	27.9%	6.8%	1.0%	3637
Sucre	49.2%	24.7%	19.1%	6.1%	0.8%	5367
Tolima	45.3%	24.0%	23.9%	5.6%	1.3%	6918
Tuluá	43.4%	19.6%	30.0%	6.2%	0.7%	1849
Tumaco	51.5%	23.3%	17.4%	6.6%	1.2%	1327
Tunja	30.8%	15.7%	44.9%	7.1%	1.5%	1487
Turbo	50.7%	25.9%	14.9%	6.2%	2.3%	997
Uribe	55.8%	25.3%	11.6%	7.2%	0.0%	292
Valle del Cauca	46.1%	20.5%	26.0%	5.7%	1.8%	6866
Valledupar	44.4%	20.2%	24.1%	6.1%	5.2%	3938
Vaupés	44.8%	23.4%	20.1%	8.4%	3.2%	154
Vichada	50.2%	24.5%	20.1%	4.5%	0.7%	269
Villavicencio	39.3%	17.8%	35.7%	6.6%	0.6%	3947
Yopal	33.1%	20.6%	39.3%	6.0%	1.0%	1272
Zipaquirá	30.1%	17.6%	45.0%	7.1%	0.2%	1110
Colombia	40.5%	19.7%	32.0%	6.5%	1.2%	366392

*Es posible que los porcentajes mostrados no sumen exactamente 100 debido a aproximaciones decimales.

• **Pregunta 34.**

Tres esferas de plata de 3 mm de diámetro, como la que se muestra en la figura, se van a guardar en una caja.

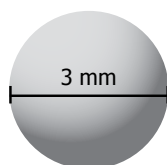

Figura

¿En cuál(es) de las siguientes cajas, se pueden guardar las esferas?

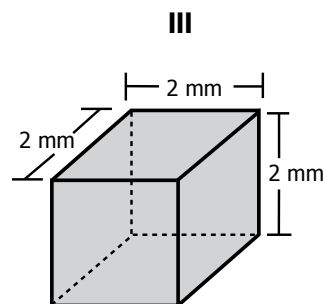
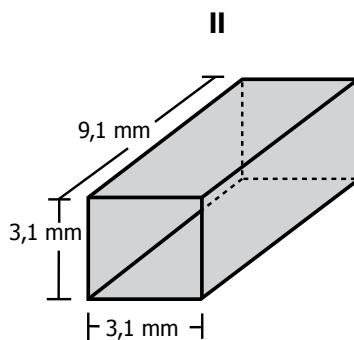
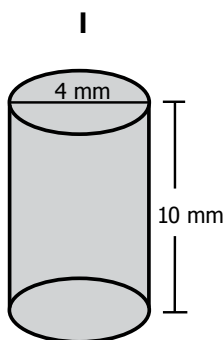

- A. En I solamente.
- B. En III solamente.
- C. En I y II solamente.
- D. En II y III solamente.

• **Estructura**

Competencia	Razonamiento
Componente	Espacial - métrico
Afirmación	Argumentar formal e informalmente sobre propiedades y relaciones de figuras planas y sólidos.
Nivel de desempeño	Satisfactorio
Respuesta Correcta	C

• Resultados a nivel nacional y de Entidad Territorial Certificada (ETC)

ETC/País	A	B	C	D	Omisión y multimarca	N° estudiantes
Amazonas	31.7%	15.1%	41.6%	10.0%	1.5%	589
Antioquia	23.5%	13.1%	51.8%	9.0%	2.7%	16848
Apartadó	26.6%	16.6%	46.6%	9.2%	1.0%	1018
Arauca	23.9%	11.7%	56.8%	7.3%	0.4%	1612
Armenia	19.6%	12.3%	60.2%	7.5%	0.4%	2415
Atlántico	26.6%	16.8%	44.5%	10.3%	1.7%	4581
Barrancabermeja	21.5%	12.7%	57.5%	7.2%	1.1%	1899
Barranquilla	23.6%	12.0%	56.0%	7.1%	1.3%	9986
Bello	19.3%	12.2%	60.7%	6.9%	1.0%	3094
Bogotá, D.C.	17.4%	7.6%	68.5%	5.6%	1.0%	60316
Bolívar	27.0%	17.9%	41.7%	11.8%	1.6%	7074
Boyacá	20.3%	8.8%	61.8%	8.1%	0.9%	7298
Bucaramanga	17.5%	7.2%	69.3%	4.8%	1.2%	4683
Buenaventura	26.6%	17.6%	43.6%	10.5%	1.7%	2198
Buga	23.6%	10.3%	56.3%	7.6%	2.3%	886
Caldas	24.7%	12.0%	54.1%	8.4%	0.8%	4246
Cali	20.8%	11.4%	59.8%	6.5%	1.4%	16005
Caquetá	26.1%	13.3%	51.3%	7.6%	1.8%	1584
Cartagena	24.2%	15.4%	50.5%	8.0%	1.8%	8876
Cartago	21.4%	11.6%	58.5%	6.8%	1.6%	863
Casanare	20.3%	10.6%	60.9%	6.9%	1.3%	2077
Cauca	27.9%	14.1%	46.8%	9.4%	1.8%	7914
Cesar	25.9%	15.9%	47.4%	9.5%	1.3%	5115
Chocó	30.0%	22.6%	32.8%	13.1%	1.6%	1899
Chía	16.0%	7.1%	71.4%	4.8%	0.7%	1290
Ciénaga	30.8%	19.2%	37.7%	10.5%	1.8%	996
Cundinamarca	19.6%	8.7%	63.7%	6.5%	1.5%	13474
Córdoba	27.7%	17.2%	42.3%	11.6%	1.2%	8801
Cúcuta	23.1%	10.2%	59.2%	7.2%	0.3%	6037
Dosquebradas	20.5%	10.7%	62.5%	5.1%	1.2%	1266
Duitama	13.3%	6.5%	75.0%	4.7%	0.6%	1069
Envigado	15.2%	9.0%	69.8%	5.4%	0.7%	1675
Facatativá	19.4%	7.6%	65.4%	6.7%	0.9%	1064
Florencia	24.4%	10.2%	58.7%	6.5%	0.2%	1285
Floridablanca	16.4%	7.2%	70.5%	5.4%	0.5%	2014
Fusagasugá	19.5%	6.9%	66.7%	6.7%	0.2%	1228
Girardot	22.9%	13.1%	54.3%	9.3%	0.4%	901

Continúa en la siguiente página



ETC/País	A	B	C	D	Omisión y multimarca	N° estudiantes
Girón	18.4%	8.9%	66.4%	5.4%	0.8%	944
Guainía	29.0%	16.0%	46.9%	8.0%	0.0%	162
Guaviare	27.1%	14.8%	47.5%	8.2%	2.4%	575
Huila	23.4%	11.4%	56.5%	7.9%	0.9%	5158
Ibagué	18.9%	10.5%	63.1%	6.5%	1.0%	4329
Ipiales	17.9%	8.3%	66.9%	6.0%	0.8%	1010
Itagüí	18.7%	16.2%	53.7%	8.9%	2.5%	1499
Jamundí	23.2%	11.5%	57.2%	7.7%	0.5%	885
La Guajira	28.9%	17.2%	43.2%	9.4%	1.2%	1790
Lorica	29.0%	18.6%	39.7%	11.3%	1.4%	1169
Magangué	29.2%	15.0%	43.2%	8.7%	4.0%	901
Magdalena	31.2%	18.8%	36.6%	11.6%	1.7%	5175
Maicao	27.1%	18.8%	41.6%	11.6%	0.9%	1131
Malambo	24.1%	15.1%	49.0%	11.0%	0.8%	837
Manizales	20.4%	11.3%	60.7%	7.0%	0.7%	2880
Medellín	19.2%	11.8%	59.4%	7.9%	1.6%	16969
Meta	24.1%	10.7%	55.4%	8.8%	1.0%	3387
Montería	23.8%	14.1%	53.3%	8.0%	0.8%	3977
Mosquera	19.0%	5.9%	68.9%	5.8%	0.4%	1035
Nariño	23.6%	10.8%	56.8%	7.6%	1.2%	5981
Neiva	22.9%	9.7%	60.7%	6.1%	0.6%	3002
Norte de Santander	23.5%	11.0%	57.4%	7.3%	0.8%	4842
Palmira	20.9%	10.3%	62.0%	5.8%	0.9%	2250
Pasto	19.4%	8.4%	65.8%	5.5%	0.8%	3681
Pereira	19.9%	9.3%	63.6%	6.4%	0.8%	3672
Piedecuesta	18.8%	10.0%	63.5%	7.3%	0.4%	1186
Pitalito	18.3%	11.1%	61.8%	8.8%	0.0%	1114
Popayán	20.1%	7.4%	65.5%	6.1%	0.9%	2345
Putumayo	23.0%	11.3%	56.4%	7.7%	1.6%	2503
Quibdó	31.5%	18.8%	36.0%	12.2%	1.5%	1232
Quindío	24.4%	12.8%	54.4%	7.6%	0.7%	2067
Riohacha	28.4%	15.9%	43.9%	10.6%	1.1%	1325
Rionegro	18.2%	10.1%	63.6%	7.4%	0.7%	1074
Risaralda	23.7%	10.8%	56.9%	8.0%	0.6%	1906
Sabaneta	17.9%	9.9%	61.3%	4.4%	6.5%	525
Sahagún	26.1%	16.1%	46.6%	11.1%	0.1%	1089
San Andrés	27.2%	22.9%	39.2%	9.1%	1.6%	449
Santa Marta	26.4%	14.5%	49.0%	8.9%	1.2%	4138
Santander	21.8%	9.8%	60.8%	7.1%	0.6%	6247

Continúa en la siguiente página

ETC/País	A	B	C	D	Omisión y multimarca	N° estudiantes
Sincelejo	24.8%	14.3%	51.5%	8.7%	0.7%	2463
Soacha	19.4%	9.8%	63.2%	6.7%	0.9%	4521
Sogamoso	14.7%	6.9%	71.6%	4.7%	2.1%	1361
Soledad	25.8%	12.3%	53.5%	7.5%	0.9%	3637
Sucre	28.7%	17.9%	41.7%	10.9%	0.8%	5367
Tolima	26.8%	12.5%	49.2%	10.0%	1.5%	6918
Tuluá	22.0%	10.8%	58.8%	7.9%	0.4%	1849
Tumaco	24.7%	18.8%	43.3%	11.5%	1.6%	1327
Tunja	17.7%	6.6%	68.8%	5.4%	1.5%	1487
Turbo	28.9%	20.0%	37.2%	11.2%	2.7%	997
Uribe	25.7%	22.3%	38.0%	13.7%	0.3%	292
Valle del Cauca	25.1%	12.9%	52.1%	8.1%	1.9%	6866
Valledupar	25.9%	13.6%	47.7%	7.9%	5.0%	3938
Vaupés	26.6%	19.5%	39.6%	11.0%	3.2%	154
Vichada	27.1%	11.5%	52.0%	8.9%	0.4%	269
Villavicencio	19.1%	10.5%	63.0%	6.8%	0.6%	3947
Yopal	16.7%	7.7%	67.8%	6.7%	1.0%	1272
Zipaquirá	17.4%	6.5%	70.2%	5.9%	0.1%	1110
Colombia	22.1%	11.6%	57.4%	7.7%	1.3%	366392

*Es posible que los porcentajes mostrados no sumen exactamente 100 debido a aproximaciones decimales.

• **Pregunta 35.**

La figura muestra tres sólidos.

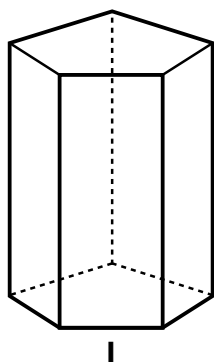

I

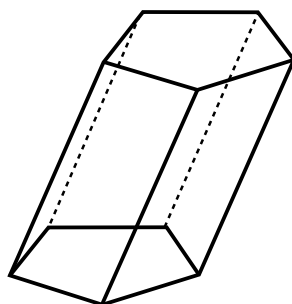

II

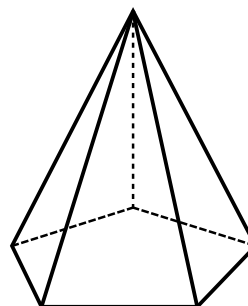

III

Figura

¿Cuál de las siguientes afirmaciones acerca de los sólidos es verdadera?

- A. Todos son pirámides.
- B. Dos de ellos tienen caras perpendiculares a la base.
- C. Todos tienen base pentagonal.
- D. Uno de ellos tiene solamente cinco caras.

• **Estructura**

Competencia	Razonamiento
Componente	Espacial - métrico
Afirmación	Argumentar formal e informalmente sobre propiedades y relaciones de figuras planas y sólidos.
Nivel de desempeño	Satisfactorio
Respuesta Correcta	C

• Resultados a nivel nacional y de Entidad Territorial Certificada (ETC)

ETC/País	A	B	C	D	Omisión y multimarca	N° estudiantes
Amazonas	9.0%	30.7%	41.6%	16.6%	2.0%	589
Antioquia	9.9%	28.3%	44.0%	15.0%	2.9%	16848
Apartadó	10.1%	31.1%	41.7%	15.5%	1.5%	1018
Arauca	8.0%	28.2%	49.8%	13.4%	0.6%	1612
Armenia	8.2%	28.3%	49.6%	13.3%	0.6%	2415
Atlántico	10.8%	29.0%	42.7%	15.5%	2.0%	4581
Barrancabermeja	8.5%	27.0%	52.1%	11.4%	1.0%	1899
Barranquilla	8.4%	26.0%	52.7%	11.5%	1.4%	9986
Bello	8.0%	25.7%	54.9%	10.2%	1.1%	3094
Bogotá, D.C.	5.5%	23.2%	61.3%	9.0%	1.0%	60316
Bolívar	12.8%	30.2%	38.3%	16.9%	1.9%	7074
Boyacá	7.7%	26.9%	51.9%	12.6%	1.0%	7298
Bucaramanga	5.6%	22.2%	63.2%	7.8%	1.2%	4683
Buenaventura	11.8%	31.6%	36.0%	18.8%	1.8%	2198
Buga	5.8%	27.7%	51.8%	12.3%	2.5%	886
Caldas	8.0%	30.2%	45.1%	15.9%	0.9%	4246
Cali	7.5%	26.0%	53.8%	11.1%	1.6%	16005
Caquetá	9.7%	29.6%	42.5%	16.3%	1.9%	1584
Cartagena	10.4%	26.5%	47.3%	13.8%	2.0%	8876
Cartago	7.9%	27.2%	49.9%	13.0%	2.0%	863
Casanare	7.9%	29.3%	48.2%	13.1%	1.4%	2077
Cauca	9.6%	30.5%	38.8%	19.0%	2.0%	7914
Cesar	11.5%	29.3%	40.5%	17.3%	1.4%	5115
Chocó	14.5%	29.4%	30.6%	23.3%	2.1%	1899
Chía	4.1%	21.4%	67.1%	6.7%	0.7%	1290
Ciénaga	12.7%	30.2%	36.1%	19.1%	1.9%	996
Cundinamarca	6.5%	25.2%	56.0%	10.8%	1.5%	13474
Córdoba	11.6%	31.7%	39.1%	16.2%	1.4%	8801
Cúcuta	7.8%	27.9%	52.3%	11.6%	0.4%	6037
Dosquebradas	5.9%	27.0%	54.3%	11.8%	0.9%	1266
Duitama	5.1%	19.5%	68.0%	6.6%	0.8%	1069
Envigado	7.3%	20.5%	63.1%	8.3%	0.8%	1675
Facatativá	5.3%	25.5%	57.8%	10.4%	1.0%	1064
Florencia	7.9%	30.1%	49.9%	11.6%	0.5%	1285
Floridablanca	6.5%	23.2%	62.4%	7.2%	0.7%	2014
Fusagasugá	7.6%	23.2%	56.7%	11.9%	0.7%	1228
Girardot	8.8%	28.5%	47.4%	14.8%	0.6%	901

Continúa en la siguiente página



ETC/País	A	B	C	D	Omisión y multimarca	N° estudiantes
Girón	6.5%	27.8%	55.7%	8.8%	1.3%	944
Guainía	12.3%	24.7%	48.8%	14.2%	0.0%	162
Guaviare	10.1%	32.2%	40.7%	14.8%	2.3%	575
Huila	7.2%	29.9%	48.4%	13.2%	1.2%	5158
Ibagué	6.3%	25.8%	55.2%	11.5%	1.2%	4329
Ipiales	7.8%	25.4%	56.2%	9.7%	0.8%	1010
Itagüí	9.8%	24.3%	50.8%	12.3%	2.8%	1499
Jamundí	8.5%	28.1%	48.6%	14.2%	0.6%	885
La Guajira	11.4%	29.3%	41.5%	16.4%	1.5%	1790
Lorica	10.9%	31.1%	37.9%	19.1%	1.0%	1169
Magangué	9.9%	31.5%	38.4%	15.9%	4.3%	901
Magdalena	12.4%	29.1%	36.5%	20.0%	1.9%	5175
Maicao	12.9%	31.2%	38.3%	17.1%	0.5%	1131
Malambo	7.9%	28.0%	49.6%	13.0%	1.6%	837
Manizales	6.4%	26.7%	54.4%	11.6%	0.9%	2880
Medellín	8.8%	25.4%	52.6%	11.3%	1.8%	16969
Meta	7.0%	27.8%	50.3%	13.7%	1.2%	3387
Montería	9.5%	29.1%	46.0%	14.5%	0.9%	3977
Mosquera	4.3%	21.7%	63.2%	10.3%	0.4%	1035
Nariño	8.8%	27.3%	47.7%	14.6%	1.6%	5981
Neiva	6.9%	26.5%	55.6%	10.3%	0.7%	3002
Norte de Santander	8.9%	27.7%	48.9%	13.6%	0.8%	4842
Palmira	8.1%	25.6%	55.8%	9.4%	1.1%	2250
Pasto	7.0%	24.3%	58.8%	8.8%	1.1%	3681
Pereira	7.0%	26.7%	53.3%	12.2%	0.9%	3672
Piedecuesta	6.2%	27.1%	55.4%	10.8%	0.5%	1186
Pitalito	6.4%	27.8%	54.0%	10.9%	0.9%	1114
Popayán	6.3%	22.9%	58.9%	10.5%	1.4%	2345
Putumayo	10.1%	29.2%	44.9%	14.3%	1.6%	2503
Quibdó	12.7%	29.1%	36.2%	20.3%	1.7%	1232
Quindío	8.2%	31.0%	46.8%	13.0%	1.0%	2067
Riohacha	11.3%	26.8%	45.7%	15.1%	1.1%	1325
Rionegro	6.9%	28.9%	53.4%	10.1%	0.8%	1074
Risaralda	7.6%	29.5%	45.7%	16.4%	0.8%	1906
Sabaneta	4.8%	20.8%	61.1%	6.9%	6.5%	525
Sahagún	10.7%	30.4%	44.5%	14.0%	0.3%	1089
San Andrés	12.7%	25.2%	47.4%	12.5%	2.2%	449
Santa Marta	10.1%	28.9%	44.4%	15.0%	1.7%	4138
Santander	7.7%	26.8%	52.7%	12.1%	0.7%	6247

Continúa en la siguiente página

ETC/País	A	B	C	D	Omisión y multimarca	N° estudiantes
Sincelejo	9.1%	28.4%	49.3%	12.4%	0.8%	2463
Soacha	5.7%	28.0%	54.1%	11.3%	0.9%	4521
Sogamoso	5.6%	24.9%	58.9%	8.3%	2.3%	1361
Soledad	9.7%	27.4%	49.2%	12.3%	1.4%	3637
Sucre	11.3%	30.7%	39.6%	17.3%	1.2%	5367
Tolima	8.6%	30.8%	42.6%	16.5%	1.5%	6918
Tuluá	8.1%	28.0%	49.8%	13.3%	0.8%	1849
Tumaco	11.9%	27.6%	36.2%	22.4%	1.9%	1327
Tunja	4.3%	20.5%	66.4%	7.1%	1.7%	1487
Turbo	14.9%	30.7%	32.2%	19.1%	3.1%	997
Uribe	7.9%	34.6%	40.1%	16.4%	1.0%	292
Valle del Cauca	8.4%	29.0%	45.6%	14.9%	2.0%	6866
Valledupar	10.1%	25.0%	46.1%	13.5%	5.3%	3938
Vaupés	9.1%	26.6%	42.2%	17.5%	4.5%	154
Vichada	7.8%	34.2%	43.5%	13.8%	0.7%	269
Villavicencio	6.5%	26.6%	55.4%	10.9%	0.6%	3947
Yopal	6.4%	24.8%	57.5%	10.1%	1.2%	1272
Zipaquirá	4.6%	23.4%	63.8%	8.0%	0.2%	1110
Colombia	8.2%	26.8%	50.9%	12.7%	1.4%	366392

*Es posible que los porcentajes mostrados no sumen exactamente 100 debido a aproximaciones decimales.

• **Pregunta 36.**

Algunos números naturales que tienen k dígitos, son iguales a la suma de cada uno de sus dígitos elevados a la potencia k .

Por ejemplo, 370 es un número que cumple esta condición, porque $k = 3$, entonces:

$$\begin{aligned}370 &= 3^3 + 7^3 + 0^3 \\370 &= 27 + 343 + 0 \\370 &= 370\end{aligned}$$

¿Cuál de los siguientes números cumple también esta condición?

- A. 19, porque $1(1^2) + 2(3^2) = 19$
- B. 32, porque $2^3 + 2 = 32$
- C. 153, porque $1^3 + 5^3 + 3^3 = 153$
- D. 512, porque $(5 + 1 + 2)^3 = 512$

• **Estructura**

Competencia	Razonamiento
Componente	Numérico - variacional
Afirmación	Verificar conjeturas acerca de los números reales, usando procesos inductivos y deductivos desde el lenguaje algebraico.
Nivel de desempeño	Avanzado
Respuesta Correcta	C

• Resultados a nivel nacional y de Entidad Territorial Certificada (ETC)

ETC/País	A	B	C	D	Omisión y multimarca	N° estudiantes
Amazonas	20.9%	25.3%	38.4%	13.4%	2.0%	589
Antioquia	21.3%	22.4%	39.0%	14.1%	3.1%	16848
Apartadó	21.3%	24.7%	38.5%	14.1%	1.4%	1018
Arauca	21.8%	24.6%	37.5%	15.3%	0.8%	1612
Armenia	22.6%	22.3%	41.9%	12.2%	1.0%	2415
Atlántico	21.6%	23.4%	38.7%	14.0%	2.3%	4581
Barrancabermeja	22.7%	22.0%	41.4%	12.4%	1.4%	1899
Barranquilla	21.9%	22.0%	40.9%	13.3%	1.9%	9986
Bello	20.6%	22.8%	41.6%	13.4%	1.6%	3094
Bogotá, D.C.	21.8%	20.5%	43.8%	12.5%	1.4%	60316
Bolívar	21.2%	25.2%	37.9%	13.5%	2.2%	7074
Boyacá	20.3%	22.8%	42.4%	13.3%	1.1%	7298
Bucaramanga	20.5%	19.9%	45.3%	12.7%	1.6%	4683
Buenaventura	20.7%	24.7%	39.2%	13.2%	2.2%	2198
Buga	17.9%	23.9%	42.7%	12.5%	2.9%	886
Caldas	20.7%	23.2%	40.5%	14.7%	1.0%	4246
Calí	20.9%	21.8%	41.9%	13.3%	2.2%	16005
Caquetá	21.0%	23.2%	40.8%	12.4%	2.5%	1584
Cartagena	21.1%	21.9%	41.2%	13.3%	2.5%	8876
Cartago	22.4%	24.9%	37.0%	13.7%	2.1%	863
Casanare	20.9%	22.6%	43.3%	11.7%	1.5%	2077
Cauca	19.0%	23.7%	41.7%	13.3%	2.3%	7914
Cesar	20.7%	24.4%	39.5%	13.9%	1.6%	5115
Chocó	20.5%	24.1%	38.7%	14.6%	2.1%	1899
Chía	19.8%	19.8%	46.6%	12.6%	1.2%	1290
Ciénaga	22.2%	24.7%	37.2%	13.7%	2.2%	996
Cundinamarca	21.5%	21.5%	42.6%	12.7%	1.7%	13474
Córdoba	21.7%	25.1%	38.0%	13.6%	1.7%	8801
Cúcuta	21.4%	21.9%	44.0%	12.1%	0.6%	6037
Dosquebradas	21.5%	22.7%	40.0%	14.4%	1.4%	1266
Duitama	17.9%	20.0%	53.0%	8.3%	0.7%	1069
Envigado	20.0%	20.4%	44.8%	13.9%	0.9%	1675
Facatativá	21.4%	20.3%	44.4%	12.7%	1.2%	1064
Florencia	19.4%	23.1%	44.0%	12.7%	0.8%	1285
Floridablanca	22.1%	18.3%	45.6%	13.6%	0.4%	2014
Fusagasugá	20.8%	21.7%	45.1%	11.7%	0.7%	1228
Girardot	21.3%	27.0%	38.3%	12.1%	1.3%	901

Continúa en la siguiente página



ETC/País	A	B	C	D	Omisión y multimarca	N° estudiantes
Girón	21.4%	21.7%	44.4%	11.0%	1.5%	944
Guainía	21.6%	22.2%	40.7%	14.2%	1.2%	162
Guaviare	19.8%	27.3%	34.8%	15.1%	3.0%	575
Huila	20.5%	23.0%	41.7%	13.4%	1.4%	5158
Ibagué	22.7%	21.3%	41.6%	13.1%	1.4%	4329
Ipiales	19.6%	22.7%	44.7%	12.0%	1.1%	1010
Itagüí	20.9%	23.4%	38.6%	14.2%	2.9%	1499
Jamundí	21.8%	21.8%	41.4%	14.1%	0.9%	885
La Guajira	20.3%	23.7%	41.8%	12.7%	1.5%	1790
Lorica	21.0%	25.6%	37.5%	14.9%	1.0%	1169
Magangué	21.9%	20.4%	38.7%	14.7%	4.3%	901
Magdalena	21.2%	25.3%	36.8%	14.5%	2.2%	5175
Maicao	23.6%	23.9%	37.6%	13.8%	1.1%	1131
Malambo	21.9%	26.5%	38.4%	12.2%	1.1%	837
Manizales	20.9%	21.9%	42.4%	13.8%	1.0%	2880
Medellín	21.1%	23.1%	39.8%	14.0%	2.1%	16969
Meta	21.4%	23.4%	40.3%	13.4%	1.4%	3387
Montería	23.0%	23.7%	39.2%	12.9%	1.2%	3977
Mosquera	21.5%	25.6%	40.8%	11.5%	0.6%	1035
Nariño	19.4%	22.0%	44.1%	12.4%	2.1%	5981
Neiva	19.8%	23.1%	43.7%	12.1%	1.3%	3002
Norte de Santander	21.4%	22.9%	40.6%	14.0%	1.2%	4842
Palmira	21.7%	21.0%	42.3%	13.2%	1.7%	2250
Pasto	21.4%	22.2%	42.2%	13.0%	1.4%	3681
Pereira	20.8%	22.2%	42.3%	13.5%	1.1%	3672
Piedecuesta	21.1%	20.7%	45.6%	12.0%	0.7%	1186
Pitalito	21.6%	21.9%	43.7%	12.1%	0.6%	1114
Popayán	21.7%	20.6%	44.4%	11.6%	1.7%	2345
Putumayo	19.5%	24.2%	41.4%	13.5%	1.5%	2503
Quibdó	22.0%	25.4%	36.6%	13.7%	2.3%	1232
Quindío	23.5%	24.5%	36.9%	14.1%	1.0%	2067
Riohacha	24.3%	22.5%	37.5%	14.3%	1.4%	1325
Rionegro	20.1%	21.4%	44.8%	12.8%	0.9%	1074
Risaralda	21.2%	21.5%	43.2%	13.2%	0.9%	1906
Sabaneta	15.6%	22.5%	41.7%	13.3%	6.9%	525
Sahagún	21.5%	24.2%	39.1%	14.8%	0.5%	1089
San Andrés	20.3%	24.1%	35.6%	18.0%	2.0%	449
Santa Marta	20.8%	24.3%	39.6%	13.3%	2.0%	4138
Santander	20.2%	24.0%	42.2%	12.5%	1.1%	6247

Continúa en la siguiente página

ETC/País	A	B	C	D	Omisión y multimarca	N° estudiantes
Sincelejo	22.8%	21.2%	42.8%	12.2%	1.0%	2463
Soacha	22.1%	22.0%	42.0%	12.4%	1.4%	4521
Sogamoso	21.7%	19.9%	44.6%	11.5%	2.4%	1361
Soledad	23.5%	21.7%	40.0%	13.5%	1.3%	3637
Sucre	22.5%	23.7%	38.7%	13.7%	1.5%	5367
Tolima	20.2%	23.8%	40.4%	13.8%	1.8%	6918
Tuluá	22.8%	24.6%	39.4%	12.3%	1.0%	1849
Tumaco	20.3%	22.2%	39.5%	16.0%	2.0%	1327
Tunja	22.1%	20.7%	44.3%	11.2%	1.7%	1487
Turbo	21.6%	25.7%	35.0%	14.5%	3.2%	997
Uribe	18.2%	29.5%	37.0%	13.4%	2.1%	292
Valle del Cauca	21.3%	23.3%	39.1%	14.0%	2.3%	6866
Valledupar	21.1%	22.0%	38.6%	12.9%	5.4%	3938
Vaupés	24.7%	20.1%	40.9%	9.7%	4.5%	154
Vichada	24.2%	25.3%	38.7%	10.8%	1.1%	269
Villavicencio	22.1%	21.9%	42.9%	12.3%	0.8%	3947
Yopal	20.5%	21.2%	43.6%	13.3%	1.4%	1272
Zipaquirá	22.9%	19.2%	45.3%	12.2%	0.5%	1110
Colombia	21.3%	22.4%	41.4%	13.2%	1.7%	366392

*Es posible que los porcentajes mostrados no sumen exactamente 100 debido a aproximaciones decimales.

• **Pregunta 37.**

Un fabricante de camisas les paga a sus empleados \$500.000 de salario básico, más una comisión de \$3.000 por cada camisa que vendan.

La expresión que permite determinar la cantidad de dinero que el fabricante debe pagar a cada empleado es $S = 3.000C + 500.000$, donde S representa el pago y C el número de camisas vendidas.

¿En cuál de las siguientes tablas se representa correctamente la relación entre el pago que recibe un empleado y el número de camisas vendidas?

A.

Número C de camisas vendidas	Pago S (en pesos)
1	503.000
2	503.000
3	503.000
4	503.000
5	503.000

B.

Número C de camisas vendidas	Pago S (en pesos)
1	503.000
2	506.000
3	509.000
4	512.000
5	515.000

C.

Número C de camisas vendidas	Pago S (en pesos)
1	503.000
2	1'003.000
3	1'503.000
4	2'003.000
5	2'503.000

D.

Número C de camisas vendidas	Pago S (en pesos)
1	503.000
2	1'006.000
3	1'509.000
4	2'012.000
5	2'515.000

- Estructura

Competencia	Comunicación
Componente	Numérico - variacional
Afirmación	Usar y relacionar diferentes representaciones para modelar situaciones de variación, y viceversa.
Nivel de desempeño	Satisfactorio
Respuesta Correcta	B

- Resultados a nivel nacional y de Entidad Territorial Certificada (ETC)

ETC/País	A	B	C	D	Omisión y multimarca	N° estudiantes
Amazonas	24.1%	39.0%	18.3%	15.8%	2.7%	589
Antioquia	13.8%	52.8%	14.3%	15.9%	3.3%	16848
Apartadó	16.0%	46.6%	17.4%	18.4%	1.7%	1018
Arauca	11.7%	56.1%	13.1%	17.9%	1.2%	1612
Armenia	11.8%	57.0%	15.6%	14.8%	0.8%	2415
Atlántico	17.6%	45.0%	16.6%	18.7%	2.1%	4581
Barrancabermeja	13.3%	53.7%	15.4%	16.2%	1.4%	1899
Barranquilla	13.6%	56.8%	12.7%	15.2%	1.7%	9986
Bello	13.2%	57.5%	13.6%	14.1%	1.6%	3094
Bogotá, D.C.	9.7%	65.1%	11.0%	12.7%	1.6%	60316
Bolívar	19.5%	40.2%	18.1%	20.0%	2.2%	7074
Boyacá	12.0%	58.6%	12.2%	15.7%	1.4%	7298
Bucaramanga	9.2%	66.5%	10.0%	12.6%	1.6%	4683
Buenaventura	18.9%	45.1%	15.8%	18.2%	2.0%	2198
Buga	12.0%	59.7%	11.6%	13.9%	2.8%	886
Caldas	14.4%	56.5%	12.8%	15.2%	1.2%	4246
Cali	12.5%	58.5%	12.8%	13.9%	2.3%	16005
Caquetá	16.2%	51.8%	14.0%	15.7%	2.3%	1584
Cartagena	14.5%	51.6%	14.8%	16.7%	2.4%	8876
Cartago	11.4%	55.5%	17.3%	13.8%	2.1%	863
Casanare	11.6%	57.4%	13.5%	15.9%	1.6%	2077
Cauca	18.0%	48.6%	14.0%	16.8%	2.5%	7914
Cesar	17.3%	46.2%	15.8%	19.3%	1.5%	5115
Chocó	23.9%	38.1%	17.2%	18.1%	2.8%	1899
Chía	9.5%	69.2%	8.8%	11.2%	1.4%	1290

Continúa en la siguiente página

ETC/País	A	B	C	D	Omisión y multimarca	N° estudiantes
Ciénaga	17.5%	42.7%	17.5%	19.3%	3.1%	996
Cundinamarca	10.9%	61.6%	11.3%	14.1%	2.1%	13474
Córdoba	19.1%	42.9%	17.5%	18.9%	1.6%	8801
Cúcuta	12.5%	58.2%	12.9%	15.7%	0.8%	6037
Dosquebradas	11.9%	60.3%	13.5%	12.6%	1.7%	1266
Duitama	7.2%	70.9%	10.2%	11.0%	0.7%	1069
Envigado	9.4%	64.6%	11.8%	13.1%	1.1%	1675
Facatativá	9.6%	65.2%	10.7%	13.0%	1.5%	1064
Florencia	11.6%	60.2%	11.7%	15.6%	0.9%	1285
Floridablanca	8.1%	67.9%	9.6%	13.6%	0.8%	2014
Fusagasugá	10.2%	63.9%	11.2%	14.1%	0.7%	1228
Girardot	16.9%	50.3%	14.8%	17.2%	0.9%	901
Girón	9.5%	64.5%	11.9%	12.8%	1.3%	944
Guainía	15.4%	48.8%	17.3%	16.7%	1.9%	162
Guaviare	15.0%	46.3%	21.4%	13.9%	3.5%	575
Huila	14.7%	55.0%	13.3%	15.6%	1.3%	5158
Ibagué	12.0%	60.4%	12.6%	13.4%	1.6%	4329
Ipiales	12.4%	61.6%	11.6%	13.4%	1.1%	1010
Itagüí	13.7%	51.4%	16.5%	15.6%	2.9%	1499
Jamundí	13.4%	52.0%	14.8%	18.6%	1.1%	885
La Guajira	19.0%	44.2%	15.5%	19.8%	1.5%	1790
Lorica	17.9%	37.7%	20.5%	22.8%	1.1%	1169
Magangué	17.6%	43.4%	15.5%	18.5%	4.9%	901
Magdalena	20.7%	39.5%	17.5%	20.3%	2.1%	5175
Maicao	17.3%	42.1%	17.8%	21.4%	1.4%	1131
Malambo	16.6%	53.8%	12.7%	16.1%	0.8%	837
Manizales	12.2%	60.3%	13.5%	12.6%	1.4%	2880
Medellín	12.6%	56.8%	14.2%	14.3%	2.1%	16969
Meta	13.2%	55.3%	14.3%	15.9%	1.3%	3387
Montería	15.6%	50.9%	14.7%	17.4%	1.3%	3977
Mosquera	11.7%	65.2%	9.7%	12.9%	0.5%	1035
Nariño	14.7%	55.5%	12.1%	15.6%	2.1%	5981
Neiva	12.5%	59.6%	12.3%	14.2%	1.4%	3002
Norte de Santander	13.0%	56.8%	13.2%	15.8%	1.2%	4842
Palmira	11.7%	61.7%	11.7%	13.2%	1.7%	2250
Pasto	9.5%	62.8%	11.5%	15.0%	1.3%	3681
Pereira	11.8%	61.2%	12.5%	13.0%	1.6%	3672
Piedecuesta	11.3%	61.8%	10.9%	15.1%	0.9%	1186
Pitalito	12.0%	58.1%	14.2%	14.6%	1.1%	1114

Continúa en la siguiente página

GRADO 9° - MATEMÁTICAS

ETC/País	A	B	C	D	Omisión y multimarca	N° estudiantes
Popayán	11.4%	63.9%	10.7%	12.2%	1.8%	2345
Putumayo	15.5%	53.9%	13.3%	15.6%	1.8%	2503
Quibdó	20.9%	40.5%	16.3%	19.7%	2.5%	1232
Quindío	14.5%	54.3%	14.5%	15.8%	0.9%	2067
Riohacha	16.4%	50.5%	15.2%	16.7%	1.2%	1325
Rionegro	12.1%	63.0%	11.1%	12.9%	0.8%	1074
Risaralda	13.7%	56.0%	13.4%	15.8%	1.0%	1906
Sabaneta	9.1%	64.4%	9.3%	10.3%	6.9%	525
Sahagún	15.4%	47.5%	18.3%	18.3%	0.6%	1089
San Andrés	16.9%	45.0%	15.8%	20.3%	2.0%	449
Santa Marta	16.3%	48.6%	15.1%	18.0%	2.1%	4138
Santander	11.3%	59.5%	12.1%	16.0%	1.1%	6247
Sincedejo	15.2%	50.3%	16.4%	17.1%	0.9%	2463
Soacha	12.8%	59.6%	12.8%	13.6%	1.3%	4521
Sogamoso	9.5%	63.9%	11.4%	12.8%	2.4%	1361
Soledad	15.8%	54.2%	14.0%	14.7%	1.3%	3637
Sucre	18.6%	44.2%	15.9%	19.9%	1.4%	5367
Tolima	16.4%	51.0%	14.5%	16.2%	1.9%	6918
Tuluá	13.3%	57.5%	12.5%	15.1%	1.5%	1849
Tumaco	21.6%	40.7%	17.1%	18.7%	2.0%	1327
Tunja	8.0%	67.2%	10.8%	12.1%	1.8%	1487
Turbo	20.0%	36.9%	19.5%	20.3%	3.4%	997
Uribe	20.9%	40.1%	18.2%	18.5%	2.4%	292
Valle del Cauca	14.7%	52.7%	15.3%	14.9%	2.4%	6866
Valledupar	15.3%	49.9%	14.4%	14.8%	5.6%	3938
Vaupés	19.5%	42.9%	12.3%	18.2%	7.1%	154
Vichada	14.5%	51.7%	15.2%	17.1%	1.5%	269
Villavicencio	10.9%	61.8%	13.2%	12.8%	1.2%	3947
Yopal	10.8%	62.2%	10.8%	14.5%	1.7%	1272
Zipaquirá	9.9%	66.7%	11.2%	11.5%	0.7%	1110
Colombia	13.4%	56.2%	13.4%	15.2%	1.8%	366392

*Es posible que los porcentajes mostrados no sumen exactamente 100 debido a aproximaciones decimales.

• **Pregunta 38.**

A continuación se presentan cuatro cuadriláteros.

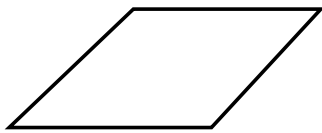

Cuadrilátero 1



Cuadrilátero 2

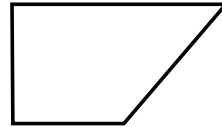

Cuadrilátero 3



Cuadrilátero 4

¿Cuál de los anteriores cuadriláteros tiene por lo menos un ángulo recto y exactamente un par de lados paralelos?

- A. Cuadrilátero 1.
- B. Cuadrilátero 2.
- C. Cuadrilátero 3.
- D. Cuadrilátero 4.

• **Estructura**

Competencia	Razonamiento
Componente	Espacial - métrico
Afirmación	Argumentar formal e informalmente sobre propiedades y relaciones de figuras planas y sólidos.
Nivel de desempeño	Avanzado
Respuesta Correcta	C

• Resultados a nivel nacional y de Entidad Territorial Certificada (ETC)

ETC/País	A	B	C	D	Omisión y multimarca	N° estudiantes
Amazonas	26.0%	31.2%	21.6%	18.7%	2.5%	589
Antioquia	27.8%	24.5%	24.7%	20.1%	2.8%	16848
Apartadó	33.6%	22.6%	20.3%	22.5%	1.0%	1018
Arauca	24.6%	27.9%	27.5%	19.5%	0.4%	1612
Armenia	29.1%	23.4%	27.2%	19.8%	0.5%	2415
Atlántico	26.9%	24.9%	25.1%	21.5%	1.7%	4581
Barrancabermeja	25.3%	25.0%	28.3%	20.3%	1.0%	1899
Barranquilla	25.3%	24.3%	29.5%	19.5%	1.3%	9986
Bello	28.5%	24.9%	24.7%	21.0%	0.9%	3094
Bogotá, D.C.	24.8%	24.3%	31.8%	17.9%	1.2%	60316
Bolívar	28.4%	26.2%	22.2%	21.5%	1.6%	7074
Boyacá	23.9%	29.7%	28.7%	16.7%	1.0%	7298
Bucaramanga	23.5%	23.7%	37.0%	14.4%	1.4%	4683
Buenaventura	30.2%	23.3%	18.9%	26.2%	1.5%	2198
Buga	22.6%	24.9%	30.6%	19.5%	2.4%	886
Caldas	28.3%	25.1%	25.1%	20.8%	0.7%	4246
Cali	27.1%	23.8%	29.6%	17.9%	1.7%	16005
Caquetá	30.4%	28.3%	22.9%	16.7%	1.7%	1584
Cartagena	28.8%	23.4%	24.5%	21.6%	1.8%	8876
Cartago	23.5%	24.3%	31.2%	19.2%	1.7%	863
Casanare	26.9%	28.6%	26.7%	16.5%	1.3%	2077
Cauca	26.9%	27.4%	26.2%	17.6%	1.9%	7914
Cesar	29.8%	25.4%	22.2%	21.5%	1.1%	5115
Chocó	29.2%	22.9%	19.1%	27.3%	1.5%	1899
Chía	20.1%	26.2%	40.1%	13.0%	0.6%	1290
Ciénaga	31.7%	19.1%	20.2%	27.3%	1.7%	996
Cundinamarca	23.9%	26.9%	30.7%	16.8%	1.6%	13474
Córdoba	27.7%	25.6%	21.9%	23.7%	1.1%	8801
Cúcuta	25.7%	24.2%	31.5%	18.1%	0.4%	6037
Dosquebradas	24.2%	25.6%	31.8%	17.1%	1.3%	1266
Duitama	18.8%	21.0%	47.7%	11.9%	0.7%	1069
Envigado	25.4%	19.1%	39.9%	14.9%	0.7%	1675
Facatativá	28.3%	24.2%	31.5%	14.9%	1.0%	1064
Florencia	27.2%	26.2%	28.5%	17.5%	0.6%	1285
Floridablanca	23.3%	22.1%	39.3%	14.7%	0.5%	2014
Fusagasugá	23.9%	24.5%	32.2%	19.3%	0.2%	1228
Girardot	30.2%	22.0%	23.0%	24.5%	0.3%	901

Continúa en la siguiente página

ETC/País	A	B	C	D	Omisión y multimarca	N° estudiantes
Girón	23.8%	27.4%	30.3%	17.4%	1.1%	944
Guainía	27.2%	35.8%	19.8%	16.0%	1.2%	162
Guaviare	26.1%	28.0%	26.4%	16.3%	3.1%	575
Huila	25.3%	27.3%	27.9%	18.3%	1.2%	5158
Ibagué	25.0%	25.5%	27.7%	20.7%	1.1%	4329
Ipiales	24.7%	24.2%	31.1%	19.4%	0.7%	1010
Itagüí	29.0%	25.1%	25.1%	18.4%	2.5%	1499
Jamundí	27.3%	22.1%	31.6%	18.1%	0.8%	885
La Guajira	27.7%	27.0%	23.5%	20.8%	1.0%	1790
Lorica	30.5%	24.6%	20.6%	23.7%	0.5%	1169
Magangué	25.9%	23.0%	21.1%	25.6%	4.4%	901
Magdalena	28.3%	26.0%	21.1%	23.0%	1.6%	5175
Maicao	28.0%	29.4%	20.2%	21.8%	0.6%	1131
Malambo	25.4%	22.3%	28.8%	22.7%	0.7%	837
Manizales	25.3%	26.3%	31.1%	16.5%	0.7%	2880
Medellín	28.1%	23.2%	27.6%	19.3%	1.8%	16969
Meta	26.4%	29.5%	24.4%	18.7%	0.9%	3387
Montería	27.5%	25.5%	24.5%	21.5%	1.0%	3977
Mosquera	21.9%	29.2%	34.0%	14.6%	0.3%	1035
Nariño	26.4%	26.7%	27.8%	17.7%	1.4%	5981
Neiva	26.5%	23.5%	31.5%	17.6%	0.8%	3002
Norte de Santander	25.4%	27.3%	27.6%	18.9%	0.8%	4842
Palmira	24.4%	23.9%	33.8%	16.7%	1.2%	2250
Pasto	26.6%	24.5%	31.1%	16.9%	1.0%	3681
Pereira	25.1%	24.0%	31.8%	18.1%	1.0%	3672
Piedecuesta	25.5%	24.5%	32.3%	17.2%	0.4%	1186
Pitalito	27.0%	28.4%	29.7%	14.8%	0.1%	1114
Popayán	23.2%	25.8%	35.6%	14.2%	1.2%	2345
Putumayo	25.0%	31.2%	27.8%	14.8%	1.2%	2503
Quibdó	30.3%	23.2%	19.6%	25.2%	1.8%	1232
Quindío	26.3%	28.0%	25.0%	20.0%	0.8%	2067
Riohacha	25.1%	27.8%	24.8%	21.4%	0.9%	1325
Rionegro	21.8%	24.9%	34.5%	18.0%	0.8%	1074
Risaralda	27.2%	26.1%	26.7%	19.3%	0.7%	1906
Sabaneta	23.8%	15.4%	36.6%	17.7%	6.5%	525
Sahagún	28.2%	25.2%	25.6%	20.5%	0.6%	1089
San Andrés	32.3%	22.9%	22.9%	20.0%	1.8%	449
Santa Marta	28.0%	24.9%	21.9%	23.7%	1.4%	4138
Santander	23.8%	27.4%	32.8%	15.3%	0.6%	6247

Continúa en la siguiente página

ETC/País	A	B	C	D	Omisión y multimarca	N° estudiantes
Sincelejo	26.6%	23.1%	28.2%	21.5%	0.7%	2463
Soacha	27.0%	27.6%	23.6%	20.7%	1.1%	4521
Sogamoso	27.1%	21.7%	33.4%	15.7%	2.1%	1361
Soledad	24.6%	24.7%	29.5%	20.1%	1.1%	3637
Sucre	27.1%	26.1%	24.3%	21.6%	0.9%	5367
Tolima	27.3%	27.0%	23.2%	21.2%	1.4%	6918
Tuluá	24.9%	25.0%	30.1%	19.2%	0.9%	1849
Tumaco	31.2%	23.5%	21.5%	22.2%	1.7%	1327
Tunja	22.3%	25.4%	37.5%	13.2%	1.5%	1487
Turbo	31.7%	24.8%	17.6%	23.2%	2.8%	997
Uribe	30.5%	27.4%	23.6%	17.8%	0.7%	292
Valle del Cauca	29.2%	24.7%	23.4%	20.7%	2.0%	6866
Valledupar	26.4%	23.3%	24.6%	20.9%	4.8%	3938
Vaupés	33.1%	23.4%	23.4%	14.3%	5.8%	154
Vichada	27.5%	35.3%	20.8%	15.2%	1.1%	269
Villavicencio	26.5%	25.3%	29.9%	17.5%	0.8%	3947
Yopal	26.1%	28.2%	27.8%	17.0%	0.9%	1272
Zipaquirá	19.8%	26.3%	37.1%	16.3%	0.5%	1110
Colombia	26.3%	25.2%	28.1%	19.1%	1.4%	366392

*Es posible que los porcentajes mostrados no sumen exactamente 100 debido a aproximaciones decimales.

• **Pregunta 39.**

*Un cuadrado de una unidad de área se dividió en nueve cuadrados congruentes y se sombrió el cuadrado central; se repitió el mismo proceso con cada uno de los ocho cuadrados no sombreados y así sucesivamente, como se muestra en la figura.

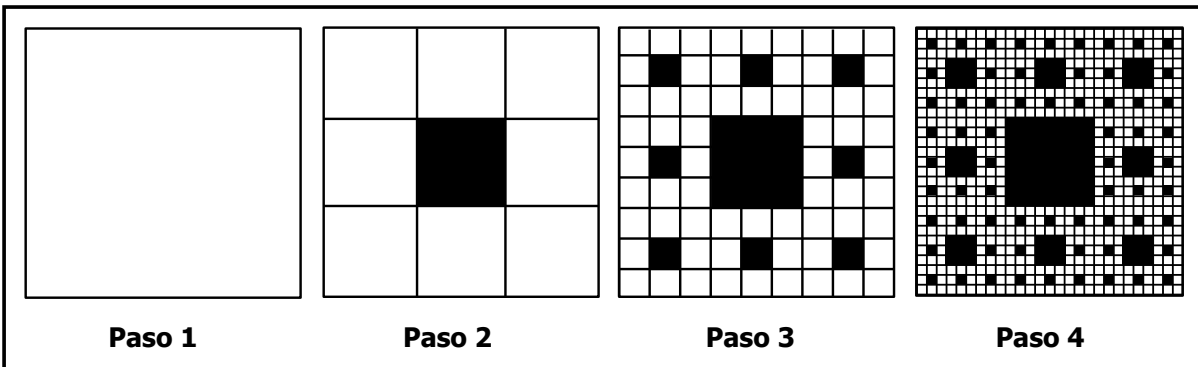

Figura

La suma de las áreas de todos los cuadrados no sombreados en el paso 3 es

- A. $\frac{8}{73}$
- B. $\frac{47}{64}$
- C. $\frac{64}{81}$
- D. $\frac{63}{72}$

• Estructura

Competencia	Resolución
Componente	Espacial - métrico
Afirmación	Resolver y formular problemas usando modelos geométricos.
Nivel de desempeño	Avanzado
Respuesta Correcta	C

• Resultados a nivel nacional y de Entidad Territorial Certificada (ETC)

ETC/País	A	B	C	D	Omisión y multimarca	N° estudiantes
Amazonas	33.1%	21.2%	31.7%	11.2%	2.7%	589
Antioquia	27.9%	21.5%	36.7%	10.7%	3.1%	16848
Apartadó	27.7%	27.8%	34.0%	9.4%	1.1%	1018
Arauca	30.1%	21.3%	37.8%	10.2%	0.6%	1612
Armenia	25.8%	23.6%	38.8%	10.9%	0.9%	2415
Atlántico	29.2%	23.4%	33.6%	11.5%	2.3%	4581
Barrancabermeja	25.5%	23.0%	38.9%	11.1%	1.5%	1899
Barranquilla	26.9%	21.2%	39.7%	10.4%	1.8%	9986
Bello	27.9%	22.6%	37.1%	11.2%	1.1%	3094
Bogotá, D.C.	24.3%	19.5%	43.1%	11.3%	1.7%	60316
Bolívar	29.1%	24.0%	33.8%	10.9%	2.2%	7074
Boyacá	25.8%	20.1%	43.0%	9.8%	1.3%	7298
Bucaramanga	23.9%	19.4%	43.7%	11.1%	1.9%	4683
Buenaventura	32.4%	23.0%	30.8%	11.8%	2.0%	2198
Buga	28.2%	21.2%	37.6%	10.3%	2.7%	886
Caldas	28.4%	21.4%	37.7%	11.5%	1.1%	4246
Cali	27.3%	21.3%	38.5%	10.6%	2.3%	16005
Caquetá	29.3%	21.9%	34.9%	11.9%	2.0%	1584
Cartagena	27.7%	22.3%	37.3%	10.3%	2.3%	8876
Cartago	26.9%	22.1%	35.6%	13.1%	2.3%	863
Casanare	28.9%	20.0%	38.8%	10.8%	1.5%	2077
Cauca	29.4%	20.3%	35.9%	12.0%	2.4%	7914
Cesar	29.1%	24.1%	35.5%	10.0%	1.2%	5115
Chocó	29.7%	23.4%	32.3%	12.1%	2.5%	1899
Chía	25.3%	17.5%	46.6%	9.3%	1.3%	1290

Continúa en la siguiente página



ETC/País	A	B	C	D	Omisión y multimarca	N° estudiantes
Ciénaga	24.6%	25.3%	36.4%	11.1%	2.5%	996
Cundinamarca	25.1%	19.1%	43.0%	10.7%	2.0%	13474
Córdoba	31.0%	23.1%	33.5%	11.1%	1.4%	8801
Cúcuta	26.6%	20.6%	42.2%	10.0%	0.6%	6037
Dosquebradas	29.1%	20.7%	38.2%	10.1%	1.8%	1266
Duitama	20.9%	19.6%	49.8%	8.5%	1.3%	1069
Envigado	23.2%	18.6%	47.2%	10.4%	0.7%	1675
Facatativá	24.8%	19.5%	44.0%	10.6%	1.1%	1064
Florencia	29.0%	20.9%	37.4%	12.0%	0.8%	1285
Floridablanca	24.9%	18.0%	44.5%	11.8%	0.8%	2014
Fusagasugá	24.8%	19.1%	44.1%	11.6%	0.4%	1228
Girardot	29.7%	21.2%	39.2%	8.9%	1.0%	901
Girón	25.0%	18.1%	45.7%	10.0%	1.3%	944
Guainía	29.0%	13.0%	40.7%	16.0%	1.2%	162
Guaviare	26.3%	23.0%	36.9%	10.1%	3.8%	575
Huila	27.2%	19.8%	41.3%	10.3%	1.4%	5158
Ibagué	27.2%	20.3%	39.4%	11.8%	1.3%	4329
Ipiales	26.2%	18.4%	42.7%	11.2%	1.5%	1010
Itagüí	26.0%	23.5%	34.8%	12.9%	2.8%	1499
Jamundí	29.5%	20.9%	36.7%	11.8%	1.1%	885
La Guajira	29.9%	23.0%	34.5%	11.2%	1.5%	1790
Lorica	29.9%	28.3%	29.2%	11.7%	0.9%	1169
Magangué	29.2%	18.5%	35.5%	12.1%	4.7%	901
Magdalena	31.6%	24.3%	30.8%	11.2%	2.1%	5175
Maicao	31.5%	22.3%	33.2%	11.9%	1.1%	1131
Malambo	29.6%	21.7%	38.6%	9.0%	1.1%	837
Manizales	27.2%	21.0%	39.9%	11.0%	1.0%	2880
Medellín	25.0%	22.7%	39.0%	11.2%	2.1%	16969
Meta	28.8%	21.2%	38.2%	10.5%	1.2%	3387
Montería	30.0%	20.4%	37.8%	10.3%	1.4%	3977
Mosquera	28.8%	18.8%	40.7%	10.9%	0.8%	1035
Nariño	27.7%	18.8%	40.6%	11.0%	1.9%	5981
Neiva	25.2%	20.6%	42.8%	10.3%	1.1%	3002
Norte de Santander	27.6%	19.3%	41.5%	10.5%	1.1%	4842
Palmira	28.0%	20.0%	40.4%	9.9%	1.6%	2250
Pasto	27.1%	18.7%	42.2%	10.9%	1.1%	3681
Pereira	27.6%	22.2%	36.6%	12.5%	1.1%	3672
Piedecuesta	24.1%	20.4%	43.4%	11.2%	0.8%	1186
Pitalito	25.6%	23.1%	41.7%	9.2%	0.4%	1114

Continúa en la siguiente página

ETC/País	A	B	C	D	Omisión y multimarca	N° estudiantes
Popayán	25.9%	19.7%	41.4%	11.3%	1.7%	2345
Putumayo	27.8%	18.8%	41.4%	10.3%	1.6%	2503
Quibdó	28.1%	23.5%	35.4%	10.6%	2.4%	1232
Quindío	28.3%	22.8%	35.9%	11.9%	1.1%	2067
Riohacha	29.4%	20.5%	37.4%	11.2%	1.4%	1325
Rionegro	24.9%	19.6%	42.3%	11.9%	1.4%	1074
Risaralda	29.9%	21.9%	37.6%	10.1%	0.6%	1906
Sabaneta	22.3%	18.7%	42.1%	9.9%	7.0%	525
Sahagún	28.9%	20.5%	37.7%	12.0%	0.8%	1089
San Andrés	25.6%	31.4%	33.2%	8.0%	1.8%	449
Santa Marta	28.0%	23.5%	35.4%	11.1%	2.0%	4138
Santander	26.8%	19.7%	42.2%	10.2%	1.2%	6247
Sincedejo	30.4%	20.8%	37.6%	10.3%	0.9%	2463
Soacha	27.4%	19.9%	40.8%	10.4%	1.5%	4521
Sogamoso	24.0%	19.7%	43.2%	10.8%	2.4%	1361
Soledad	29.3%	21.4%	37.5%	10.4%	1.4%	3637
Sucre	31.7%	21.9%	33.6%	11.5%	1.3%	5367
Tolima	28.2%	22.5%	35.9%	11.5%	1.8%	6918
Tuluá	29.8%	22.3%	34.5%	11.9%	1.5%	1849
Tumaco	31.3%	22.8%	32.9%	11.1%	1.9%	1327
Tunja	23.7%	20.2%	43.7%	10.4%	2.0%	1487
Turbo	28.8%	25.9%	30.5%	11.6%	3.2%	997
Uribe	30.5%	18.8%	36.3%	12.7%	1.7%	292
Valle del Cauca	29.8%	21.7%	34.9%	11.0%	2.7%	6866
Valledupar	29.0%	20.6%	35.0%	10.2%	5.2%	3938
Vaupés	38.3%	13.0%	28.6%	10.4%	9.7%	154
Vichada	28.3%	19.3%	34.9%	16.0%	1.5%	269
Villavicencio	25.5%	22.2%	40.9%	10.4%	0.9%	3947
Yopal	24.2%	19.1%	43.3%	11.8%	1.6%	1272
Zipaquirá	22.8%	20.9%	44.8%	10.8%	0.7%	1110
Colombia	27.1%	21.0%	39.1%	10.9%	1.8%	366392

*Es posible que los porcentajes mostrados no sumen exactamente 100 debido a aproximaciones decimales.

• **Pregunta 40.**

Paula está jugando con una ruleta dividida en tres sectores, 1, 2 y 3. Hasta el momento, ella la ha hecho girar 30 veces y ha anotado los sectores en los que se ha detenido, como se muestra en la tabla.

SECTOR DONDE SE DETUVO LA RULETA																													
1	2	1	3	3	1	1	3	1	2	1	1	1	3	1	2	1	1	2	1	3	2	1	1	2	1	1	1	3	1

Tabla

De acuerdo con la información anterior, si Paula hace girar de nuevo la ruleta, la probabilidad de que se detenga en 1 es

- A. igual a la probabilidad de que se detenga en 2.
- B. la mitad de la probabilidad de que se detenga en 2.
- C. el doble de la probabilidad de que se detenga en 3.
- D. el triple de la probabilidad de que se detenga en 3.

• **Estructura**

Competencia	Razonamiento
Componente	Aleatorio
Afirmación	Utilizar diferentes métodos y estrategias para calcular la probabilidad de eventos simples.
Nivel de desempeño	Avanzado
Respuesta Correcta	D

• Resultados a nivel nacional y de Entidad Territorial Certificada (ETC)

ETC/País	A	B	C	D	Omisión y multimarca	N° estudiantes
Amazonas	23.6%	30.2%	26.3%	16.8%	3.1%	589
Antioquia	22.7%	26.9%	21.5%	25.6%	3.3%	16848
Apartadó	22.4%	29.2%	22.5%	24.8%	1.2%	1018
Arauca	22.0%	24.7%	24.6%	27.6%	1.1%	1612
Armenia	19.6%	25.5%	23.1%	30.8%	0.9%	2415
Atlántico	23.9%	24.9%	22.4%	26.3%	2.5%	4581
Barrancabermeja	22.6%	25.8%	21.0%	29.0%	1.6%	1899
Barranquilla	20.7%	23.9%	21.9%	31.6%	1.9%	9986
Bello	21.4%	25.3%	22.2%	30.0%	1.2%	3094
Bogotá, D.C.	20.2%	23.8%	21.6%	32.8%	1.6%	60316
Bolívar	22.4%	26.7%	24.3%	24.1%	2.5%	7074
Boyacá	22.6%	27.5%	21.3%	27.4%	1.3%	7298
Bucaramanga	18.2%	23.2%	21.1%	35.7%	1.9%	4683
Buenaventura	24.4%	28.8%	21.0%	23.3%	2.4%	2198
Buga	23.3%	25.7%	19.6%	28.6%	2.8%	886
Caldas	23.0%	27.6%	22.3%	26.0%	1.1%	4246
Cali	20.4%	25.4%	21.8%	30.1%	2.3%	16005
Caquetá	21.8%	30.5%	21.9%	23.7%	2.0%	1584
Cartagena	21.6%	24.6%	22.5%	28.9%	2.4%	8876
Cartago	20.4%	26.2%	21.8%	29.7%	2.0%	863
Casanare	23.7%	28.3%	21.9%	24.7%	1.5%	2077
Cauca	23.5%	28.9%	21.7%	23.4%	2.5%	7914
Cesar	21.2%	27.3%	20.9%	29.0%	1.6%	5115
Chocó	24.3%	26.8%	25.5%	20.5%	2.8%	1899
Chía	20.4%	23.0%	20.7%	34.9%	1.0%	1290
Ciénaga	23.4%	27.9%	23.2%	22.9%	2.6%	996
Cundinamarca	22.4%	25.9%	21.2%	28.4%	2.1%	13474
Córdoba	23.0%	27.7%	24.5%	23.4%	1.5%	8801
Cúcuta	20.1%	25.1%	21.4%	32.8%	0.6%	6037
Dosquebradas	21.4%	24.1%	22.7%	29.8%	2.1%	1266
Duitama	17.0%	20.3%	21.7%	40.1%	0.8%	1069
Envigado	17.6%	22.1%	21.0%	38.1%	1.3%	1675
Facatativá	22.4%	25.0%	21.4%	29.8%	1.4%	1064
Florencia	20.7%	26.4%	22.0%	30.0%	0.9%	1285
Floridablanca	18.2%	21.4%	21.0%	38.5%	0.9%	2014
Fusagasugá	21.4%	26.3%	22.8%	28.7%	0.7%	1228
Girardot	26.2%	28.1%	23.2%	21.2%	1.3%	901

Continúa en la siguiente página



ETC/País	A	B	C	D	Omisión y multimarca	N° estudiantes
Girón	15.3%	22.1%	20.7%	40.6%	1.4%	944
Guainía	23.5%	30.2%	22.2%	21.0%	3.1%	162
Guaviare	22.4%	25.7%	23.5%	24.9%	3.5%	575
Huila	21.3%	28.2%	22.1%	27.0%	1.4%	5158
Ibagué	20.6%	25.1%	22.7%	30.1%	1.5%	4329
Ipiales	17.3%	24.5%	22.9%	34.3%	1.1%	1010
Itagüí	22.4%	24.6%	22.2%	27.6%	3.2%	1499
Jamundí	22.9%	27.9%	22.4%	25.2%	1.6%	885
La Guajira	22.9%	27.6%	22.8%	25.0%	1.7%	1790
Lorica	24.2%	28.2%	25.6%	21.1%	0.9%	1169
Magangué	21.5%	27.1%	23.0%	23.4%	5.0%	901
Magdalena	24.5%	27.8%	23.3%	22.1%	2.2%	5175
Maicao	24.3%	28.5%	23.5%	22.9%	0.8%	1131
Malambo	19.4%	23.2%	22.8%	33.6%	1.1%	837
Manizales	20.9%	25.7%	23.1%	29.2%	1.2%	2880
Medellín	21.2%	24.5%	23.0%	29.2%	2.1%	16969
Meta	22.4%	26.5%	21.0%	28.8%	1.2%	3387
Montería	21.2%	25.3%	21.5%	30.6%	1.5%	3977
Mosquera	23.8%	22.7%	21.0%	31.8%	0.8%	1035
Nariño	21.9%	26.7%	20.9%	28.7%	1.8%	5981
Neiva	19.6%	26.0%	21.8%	31.3%	1.3%	3002
Norte de Santander	22.2%	26.8%	21.0%	28.8%	1.1%	4842
Palmira	18.8%	23.6%	21.0%	35.0%	1.6%	2250
Pasto	21.5%	24.7%	21.1%	31.4%	1.3%	3681
Pereira	21.3%	23.6%	22.1%	31.8%	1.3%	3672
Piedecuesta	22.1%	24.2%	20.2%	32.8%	0.8%	1186
Pitalito	22.2%	26.2%	23.2%	27.7%	0.6%	1114
Popayán	20.9%	25.8%	20.2%	31.6%	1.5%	2345
Putumayo	21.9%	29.3%	21.9%	25.0%	1.9%	2503
Quibdó	23.8%	28.8%	21.2%	24.0%	2.2%	1232
Quindío	23.5%	25.4%	22.0%	27.8%	1.3%	2067
Riohacha	23.4%	26.6%	21.5%	27.2%	1.3%	1325
Rionegro	23.7%	22.7%	20.3%	31.8%	1.5%	1074
Risaralda	24.2%	28.2%	23.0%	23.7%	0.8%	1906
Sabaneta	17.1%	21.0%	22.7%	32.6%	6.7%	525
Sahagún	24.3%	24.7%	22.1%	28.3%	0.6%	1089
San Andrés	22.3%	25.6%	26.9%	23.6%	1.6%	449
Santa Marta	23.9%	27.3%	22.5%	24.1%	2.2%	4138
Santander	22.0%	25.1%	20.6%	31.2%	1.0%	6247

Continúa en la siguiente página

ETC/País	A	B	C	D	Omisión y multimarca	N° estudiantes
Sincelejo	21.8%	27.2%	22.6%	27.5%	0.9%	2463
Soacha	23.4%	26.5%	21.3%	27.4%	1.3%	4521
Sogamoso	21.3%	23.6%	23.3%	29.5%	2.4%	1361
Soledad	21.3%	25.8%	22.2%	29.3%	1.4%	3637
Sucre	22.7%	28.4%	23.5%	23.6%	1.8%	5367
Tolima	23.1%	28.2%	22.2%	24.6%	2.0%	6918
Tuluá	22.3%	27.2%	21.0%	27.8%	1.6%	1849
Tumaco	21.9%	29.4%	23.0%	23.5%	2.3%	1327
Tunja	19.6%	22.2%	21.9%	34.2%	2.1%	1487
Turbo	23.5%	29.0%	23.1%	21.4%	3.1%	997
Uribe	15.1%	35.3%	26.7%	21.9%	1.0%	292
Valle del Cauca	22.1%	27.5%	22.1%	25.7%	2.7%	6866
Valledupar	20.3%	23.9%	21.5%	28.5%	5.7%	3938
Vaupés	21.4%	31.2%	18.8%	18.8%	9.7%	154
Vichada	23.8%	29.7%	25.3%	19.3%	1.9%	269
Villavicencio	22.4%	25.3%	21.5%	29.5%	1.2%	3947
Yopal	21.6%	24.4%	21.8%	30.4%	1.8%	1272
Zipaquirá	22.2%	25.1%	21.1%	30.6%	1.0%	1110
Colombia	21.6%	25.7%	22.0%	28.9%	1.9%	366392

*Es posible que los porcentajes mostrados no sumen exactamente 100 debido a aproximaciones decimales.



- **Pregunta 41.**

En un grupo de 600 personas hay 375 fumadores, 200 de los cuales tienen una enfermedad respiratoria. Entre los no fumadores del grupo, 50 tienen una enfermedad respiratoria.

¿Cuál es la probabilidad de seleccionar al azar una persona de este grupo, que sea fumadora y no tenga enfermedad respiratoria?

- A. $\frac{175}{600}$
 - B. $\frac{200}{600}$
 - C. $\frac{250}{600}$
 - D. $\frac{350}{600}$
-

- **Estructura**

Competencia	Resolución
Componente	Aleatorio
Afirmación	Plantear y resolver situaciones relativas a otras ciencias utilizando conceptos de probabilidad.
Nivel de desempeño	Avanzado
Respuesta Correcta	A

• Resultados a nivel nacional y de Entidad Territorial Certificada (ETC)

ETC/País	A	B	C	D	Omisión y multimarca	N° estudiantes
Amazonas	39.7%	23.9%	18.7%	13.6%	4.1%	589
Antioquia	42.9%	23.1%	17.8%	12.9%	3.3%	16848
Apartadó	42.1%	22.7%	19.0%	14.7%	1.5%	1018
Arauca	43.3%	22.4%	20.0%	13.5%	0.7%	1612
Armenia	45.7%	22.9%	18.7%	11.8%	0.9%	2415
Atlántico	43.1%	23.1%	18.4%	13.1%	2.4%	4581
Barrancabermeja	47.6%	20.6%	16.8%	13.5%	1.5%	1899
Barranquilla	48.0%	20.7%	17.7%	11.9%	1.8%	9986
Bello	46.9%	21.2%	18.8%	12.0%	1.2%	3094
Bogotá, D.C.	47.7%	20.5%	18.3%	11.6%	1.9%	60316
Bolívar	42.0%	24.0%	19.5%	12.5%	2.0%	7074
Boyacá	43.3%	22.8%	19.2%	13.2%	1.5%	7298
Bucaramanga	49.5%	19.2%	18.0%	11.6%	1.8%	4683
Buenaventura	43.9%	22.9%	17.8%	13.1%	2.2%	2198
Buga	47.7%	20.3%	17.0%	11.6%	3.3%	886
Caldas	44.4%	21.4%	20.1%	12.8%	1.3%	4246
Cali	46.0%	21.9%	17.5%	12.2%	2.4%	16005
Caquetá	38.3%	24.2%	21.0%	14.3%	2.2%	1584
Cartagena	47.1%	21.3%	17.1%	12.3%	2.3%	8876
Cartago	45.3%	24.4%	17.8%	10.2%	2.2%	863
Casanare	40.8%	24.2%	19.8%	13.6%	1.6%	2077
Cauca	39.5%	24.4%	19.9%	13.6%	2.6%	7914
Cesar	44.6%	22.9%	18.6%	12.7%	1.3%	5115
Chocó	39.0%	25.6%	18.5%	14.3%	2.5%	1899
Chía	46.4%	19.5%	21.5%	11.5%	1.1%	1290
Ciénaga	40.0%	22.2%	19.1%	15.7%	3.1%	996
Cundinamarca	43.8%	22.1%	19.6%	12.3%	2.2%	13474
Córdoba	40.5%	25.0%	19.0%	14.2%	1.3%	8801
Cúcuta	48.1%	21.4%	17.8%	12.1%	0.7%	6037
Dosquebradas	45.0%	24.2%	18.3%	10.7%	1.8%	1266
Duitama	49.2%	18.9%	18.9%	12.2%	0.8%	1069
Envigado	53.0%	19.0%	15.9%	10.4%	1.7%	1675
Facatativá	46.9%	19.3%	20.1%	12.5%	1.2%	1064
Florencia	46.5%	20.9%	17.9%	13.8%	1.0%	1285
Floridablanca	50.4%	19.1%	17.6%	11.8%	1.1%	2014
Fusagasugá	44.2%	22.9%	21.1%	11.4%	0.4%	1228
Girardot	43.2%	22.6%	18.2%	15.0%	1.0%	901

Continúa en la siguiente página



ETC/País	A	B	C	D	Omisión y multimarca	N° estudiantes
Girón	48.3%	23.5%	15.9%	10.4%	1.9%	944
Guainía	31.5%	24.7%	30.2%	11.7%	1.9%	162
Guaviare	38.8%	25.4%	19.5%	12.5%	3.8%	575
Huila	42.4%	23.8%	19.5%	13.0%	1.4%	5158
Ibagué	46.9%	21.5%	18.3%	11.8%	1.6%	4329
Ipiales	43.9%	22.2%	21.8%	11.0%	1.2%	1010
Itagüí	46.5%	23.3%	15.3%	11.8%	3.1%	1499
Jamundí	44.7%	23.1%	18.5%	12.5%	1.1%	885
La Guajira	40.8%	24.9%	17.4%	15.3%	1.7%	1790
Lorica	38.7%	26.7%	18.8%	14.6%	1.2%	1169
Magangué	40.1%	21.9%	19.5%	13.1%	5.4%	901
Magdalena	41.2%	24.0%	18.5%	14.2%	2.1%	5175
Maicao	38.9%	25.5%	18.2%	16.4%	1.0%	1131
Malambo	51.4%	19.0%	16.5%	12.3%	0.8%	837
Manizales	45.4%	23.3%	18.2%	11.5%	1.6%	2880
Medellín	47.4%	21.1%	17.6%	11.8%	2.2%	16969
Meta	44.3%	23.9%	19.0%	11.8%	1.0%	3387
Montería	44.9%	23.4%	17.7%	12.6%	1.5%	3977
Mosquera	43.9%	23.0%	19.5%	12.8%	0.9%	1035
Nariño	43.2%	22.0%	19.5%	13.5%	1.8%	5981
Neiva	47.3%	21.4%	18.0%	12.1%	1.3%	3002
Norte de Santander	45.3%	23.3%	17.8%	12.5%	1.1%	4842
Palmira	48.2%	20.9%	17.6%	11.6%	1.8%	2250
Pasto	44.8%	21.2%	19.9%	12.7%	1.4%	3681
Pereira	47.5%	21.1%	18.4%	11.9%	1.2%	3672
Piedecuesta	49.2%	18.6%	18.6%	12.8%	0.7%	1186
Pitalito	43.9%	23.7%	18.0%	13.8%	0.5%	1114
Popayán	46.4%	22.3%	18.2%	11.3%	1.8%	2345
Putumayo	41.2%	22.9%	20.0%	14.4%	1.6%	2503
Quibdó	40.5%	22.1%	18.3%	16.6%	2.5%	1232
Quindío	43.3%	23.7%	18.6%	13.3%	1.2%	2067
Riohacha	44.4%	24.5%	14.7%	14.9%	1.4%	1325
Rionegro	45.7%	22.3%	18.6%	12.4%	1.0%	1074
Risaralda	44.1%	23.3%	19.6%	12.1%	0.9%	1906
Sabaneta	49.3%	18.1%	16.2%	9.3%	7.0%	525
Sahagún	42.5%	23.5%	20.7%	12.6%	0.7%	1089
San Andrés	46.5%	23.4%	16.3%	11.8%	2.0%	449
Santa Marta	44.5%	22.6%	17.7%	13.4%	1.9%	4138
Santander	45.8%	21.5%	19.1%	12.6%	1.0%	6247

Continúa en la siguiente página

ETC/País	A	B	C	D	Omisión y multimarca	N° estudiantes
Sincelejo	44.5%	23.3%	17.9%	13.5%	0.8%	2463
Soacha	47.9%	21.3%	16.8%	12.6%	1.4%	4521
Sogamoso	46.2%	21.5%	19.0%	10.8%	2.5%	1361
Soledad	47.4%	20.3%	18.5%	12.0%	1.7%	3637
Sucre	40.4%	25.2%	18.4%	14.6%	1.4%	5367
Tolima	40.2%	24.1%	20.6%	13.4%	1.7%	6918
Tuluá	44.9%	22.5%	17.7%	13.2%	1.7%	1849
Tumaco	38.7%	24.0%	19.6%	15.3%	2.4%	1327
Tunja	51.0%	19.6%	16.6%	11.2%	1.6%	1487
Turbo	38.9%	26.2%	17.3%	14.2%	3.4%	997
Uribe	38.0%	22.6%	25.0%	12.7%	1.7%	292
Valle del Cauca	42.4%	23.1%	18.6%	13.4%	2.5%	6866
Valledupar	43.5%	19.5%	18.2%	13.4%	5.4%	3938
Vaupés	31.2%	32.5%	16.9%	8.4%	11.0%	154
Vichada	39.4%	25.3%	18.2%	15.2%	1.9%	269
Villavicencio	46.7%	22.3%	18.5%	11.6%	0.9%	3947
Yopal	46.1%	20.9%	19.5%	11.9%	1.6%	1272
Zipacquirá	45.3%	21.8%	18.9%	13.0%	1.0%	1110
Colombia	45.0%	22.1%	18.4%	12.5%	1.9%	366392

*Es posible que los porcentajes mostrados no sumen exactamente 100 debido a aproximaciones decimales.

• **Pregunta 42.**

Una empresa utiliza teléfonos que registran la duración y la frecuencia de las últimas 20 llamadas. En la tabla se organizó el registro de uno de estos teléfonos.

Duración llamada (minutos)	Frecuencia (número de llamadas)
[4, 8)	4
[8, 12)	5
[12, 16)	7
[16, 20)	2
[20, 24)	1
[24, 28)	1

[4, 8) se lee: "Mayor o igual que 4 y menor que 8".

Tabla

La información de la tabla permite concluir correctamente que:

- A. El número de llamadas que duraron entre 16 y 20 minutos es mayor que el número de llamadas que duraron entre 4 y 8 minutos.
- B. La mitad de las llamadas duraron 16 minutos o más.
- C. El número de llamadas que duraron entre 8 y 16 minutos es mayor que el número de llamadas que duraron entre 16 y 24 minutos.
- D. La quinta parte de las llamadas duraron 10 minutos.

• **Estructura**

Competencia	Comunicación
Componente	Aleatorio
Afirmación	Comparar usar e interpretar datos que provienen de situaciones reales y traducir entre diferentes representaciones de un conjunto de datos.
Nivel de desempeño	Satisfactorio
Respuesta Correcta	C

• Resultados a nivel nacional y de Entidad Territorial Certificada (ETC)

ETC/País	A	B	C	D	Omisión y multimarca	N° estudiantes
Amazonas	30.2%	26.3%	29.2%	9.8%	4.4%	589
Antioquia	22.9%	25.2%	37.6%	10.9%	3.4%	16848
Apartadó	23.3%	27.1%	37.4%	10.6%	1.6%	1018
Arauca	20.8%	28.7%	39.1%	10.3%	1.1%	1612
Armenia	19.0%	26.5%	41.9%	11.5%	1.1%	2415
Atlántico	24.4%	25.8%	35.9%	11.4%	2.5%	4581
Barrancabermeja	21.4%	25.6%	41.5%	10.0%	1.5%	1899
Barranquilla	21.9%	24.7%	42.0%	9.5%	1.8%	9986
Bello	19.8%	26.0%	42.7%	10.1%	1.4%	3094
Bogotá, D.C.	18.7%	23.4%	46.8%	9.2%	2.0%	60316
Bolívar	25.6%	26.7%	34.8%	10.8%	2.2%	7074
Boyacá	22.0%	25.4%	40.9%	10.1%	1.5%	7298
Bucaramanga	18.0%	22.6%	48.8%	8.8%	1.8%	4683
Buenaventura	28.1%	25.8%	34.7%	8.6%	2.9%	2198
Buga	21.1%	25.8%	42.1%	7.8%	3.2%	886
Caldas	23.9%	25.6%	37.9%	11.1%	1.6%	4246
Cali	20.9%	24.7%	42.0%	9.8%	2.5%	16005
Caquetá	24.4%	26.9%	36.0%	10.5%	2.1%	1584
Cartagena	22.3%	26.4%	39.4%	9.5%	2.4%	8876
Cartago	23.6%	23.5%	39.6%	10.7%	2.5%	863
Casanare	22.3%	26.5%	39.6%	10.2%	1.5%	2077
Cauca	26.0%	26.2%	34.4%	10.8%	2.6%	7914
Cesar	25.4%	27.9%	36.0%	9.5%	1.3%	5115
Chocó	25.6%	26.2%	32.6%	12.9%	2.7%	1899
Chía	18.0%	23.4%	47.7%	9.3%	1.6%	1290
Ciénaga	25.8%	27.4%	30.7%	13.2%	2.9%	996
Cundinamarca	21.1%	24.5%	42.7%	9.5%	2.2%	13474
Córdoba	26.8%	25.8%	35.5%	10.4%	1.6%	8801
Cúcuta	19.6%	24.3%	45.4%	9.8%	0.8%	6037
Dosquebradas	19.5%	26.1%	41.9%	10.6%	1.9%	1266
Duitama	17.3%	20.9%	52.7%	8.4%	0.7%	1069
Envigado	18.0%	24.0%	48.3%	7.9%	1.8%	1675
Facatativá	22.2%	23.0%	44.4%	8.6%	1.8%	1064
Florencia	20.8%	24.7%	43.7%	9.6%	1.2%	1285
Floridablanca	18.3%	22.5%	49.4%	8.6%	1.2%	2014
Fusagasugá	19.4%	22.6%	46.3%	10.9%	0.8%	1228
Girardot	22.3%	29.4%	39.3%	8.1%	0.9%	901

Continúa en la siguiente página

ETC/País	A	B	C	D	Omisión y multimarca	N° estudiantes
Girón	18.0%	22.9%	50.1%	6.9%	2.1%	944
Guainía	29.0%	24.1%	29.6%	15.4%	1.9%	162
Guaviare	22.6%	27.0%	34.6%	11.7%	4.2%	575
Huila	22.4%	25.9%	39.9%	10.3%	1.5%	5158
Ibagué	21.8%	24.1%	42.1%	10.4%	1.6%	4329
Ipsiales	24.2%	23.8%	44.0%	7.0%	1.1%	1010
Itagüí	18.5%	28.7%	40.1%	9.6%	3.1%	1499
Jamundí	24.1%	26.1%	38.6%	9.8%	1.4%	885
La Guajira	29.7%	25.6%	33.1%	9.9%	1.7%	1790
Lorica	26.1%	26.6%	34.5%	11.5%	1.3%	1169
Magangué	24.4%	25.2%	32.7%	12.0%	5.7%	901
Magdalena	27.9%	26.4%	31.8%	11.3%	2.6%	5175
Maicao	23.5%	28.6%	37.0%	10.2%	0.8%	1131
Malambo	25.8%	26.5%	37.2%	9.7%	0.8%	837
Manizales	20.1%	24.7%	42.7%	10.8%	1.6%	2880
Medellín	18.8%	25.7%	42.0%	11.1%	2.4%	16969
Meta	21.6%	25.0%	40.6%	11.6%	1.2%	3387
Montería	23.1%	25.5%	40.1%	9.8%	1.5%	3977
Mosquera	21.5%	23.6%	44.9%	8.8%	1.2%	1035
Nariño	23.6%	25.2%	39.9%	9.4%	1.9%	5981
Neiva	21.8%	22.7%	45.8%	8.4%	1.4%	3002
Norte de Santander	22.2%	25.2%	40.6%	10.8%	1.2%	4842
Palmira	22.0%	21.5%	45.9%	8.9%	1.8%	2250
Pasto	21.5%	25.4%	43.4%	8.2%	1.5%	3681
Pereira	19.4%	24.9%	44.7%	9.7%	1.3%	3672
Piedecuesta	21.3%	23.2%	45.1%	9.5%	0.8%	1186
Pitalito	19.9%	27.6%	42.0%	9.7%	0.8%	1114
Popayán	19.8%	25.1%	44.1%	9.2%	1.9%	2345
Putumayo	23.2%	26.3%	39.8%	9.0%	1.7%	2503
Quibdó	23.3%	27.8%	35.0%	11.4%	2.6%	1232
Quindío	20.7%	25.6%	40.6%	11.6%	1.5%	2067
Riohacha	25.3%	27.7%	35.4%	9.9%	1.7%	1325
Rionegro	21.5%	21.7%	44.1%	11.1%	1.6%	1074
Risaralda	23.7%	27.0%	36.7%	11.5%	1.0%	1906
Sabaneta	12.0%	20.4%	49.3%	11.2%	7.0%	525
Sahagún	25.3%	24.1%	40.1%	9.5%	1.1%	1089
San Andrés	25.2%	27.4%	36.1%	9.4%	2.0%	449
Santa Marta	22.7%	27.6%	36.4%	10.9%	2.3%	4138
Santander	20.1%	24.8%	43.8%	10.2%	1.1%	6247

Continúa en la siguiente página

ETC/País	A	B	C	D	Omisión y multimarca	N° estudiantes
Sincelejo	23.3%	24.9%	41.0%	9.7%	1.1%	2463
Soacha	22.6%	25.0%	41.9%	9.0%	1.5%	4521
Sogamoso	20.1%	22.2%	46.9%	8.3%	2.5%	1361
Soledad	23.4%	26.8%	39.1%	9.1%	1.5%	3637
Sucre	26.7%	26.4%	35.7%	9.8%	1.4%	5367
Tolima	24.1%	26.2%	37.2%	10.6%	2.0%	6918
Tuluá	20.7%	26.9%	41.4%	9.0%	2.1%	1849
Tumaco	27.8%	27.4%	32.6%	9.5%	2.8%	1327
Tunja	17.0%	25.2%	47.3%	8.8%	1.7%	1487
Turbo	25.3%	27.6%	32.2%	12.0%	2.9%	997
Uribe	31.2%	25.0%	30.1%	13.0%	0.7%	292
Valle del Cauca	22.6%	25.8%	38.9%	10.2%	2.5%	6866
Vallidupar	23.0%	25.9%	36.6%	9.2%	5.4%	3938
Vaupés	26.6%	20.8%	29.2%	11.7%	11.7%	154
Vichada	23.0%	22.3%	37.9%	14.1%	2.6%	269
Villavicencio	19.6%	24.6%	44.8%	10.1%	1.0%	3947
Yopal	19.6%	25.3%	44.6%	9.1%	1.4%	1272
Zipaquirá	22.1%	20.9%	46.3%	9.6%	1.1%	1110
Colombia	21.8%	25.1%	41.2%	9.9%	2.0%	366392

*Es posible que los porcentajes mostrados no sumen exactamente 100 debido a aproximaciones decimales.

