



Saber 3°, 5° y 9° 2014

Cuadernillo de prueba

EJEMPLO DE PREGUNTAS
Saber 9° Matemáticas

Presidente de la República
Juan Manuel Santos Calderón

Ministra de Educación Nacional
Gina María Parody d'Echeona

Viceministro de Educación Preescolar, Básica y Media
Luis Enrique García De Brigard

Directora General
Ximena Dueñas Herrera

Secretaria General
María Sofía Arango Arango

Director de Evaluación
Andrés Gutiérrez

Director de Producción y Operaciones
Francia del Pilar Jiménez

Directora de Tecnología
Ingrid Picón Carrascal

Jefe Oficina Asesora de Comunicaciones y Mercadeo
Jimmy Alexander Lugo Guerrero

Jefe Oficina Gestión de Proyectos de Investigación
Luis Eduardo Jaramillo

Subdirectora de Producción de Instrumentos
Martha Ligia Cuevas Mendoza

Subdirector de Diseño de Instrumentos
Diego Fernando Lemus Polanía

Subdirectora de Análisis y Divulgación
Silvana Godoy Mateus

Adaptación y elaboración del documento
Martha Jeanet Castillo Ballén

Diseño y diagramación
Gustavo Andrés Álvarez Mejía
Alejandra Guzmán Escobar

ISBN de la versión digital: En trámite

Bogotá D.C., Abril de 2016



ADVERTENCIA

Con el fin de evitar la sobrecarga gráfica que supondría utilizar en español “o/a” para denotar uno u otro género, el ICFES opta por emplear el masculino genérico en el que todas las menciones de este se refieren siempre a hombres y mujeres.

Todo el contenido es propiedad exclusiva y reservada del ICFES y es el resultado de investigaciones y obras protegidas por la legislación nacional e internacional. No se autoriza su reproducción, utilización ni explotación a ningún tercero. Solo se autoriza su uso para fines exclusivamente académicos. Esta información no podrá ser alterada, modificada o enmendada.

TÉRMINOS Y CONDICIONES DE USO PARA PUBLICACIONES Y OBRAS DE PROPIEDAD DEL ICFCES

El Instituto Colombiano para la Evaluación de la Educación (Icfes) pone a la disposición de la comunidad educativa y del público en general, **DE FORMA GRATUITA Y LIBRE DE CUALQUIER CARGO**, un conjunto de publicaciones a través de su portal www.icfes.gov.co. Dichos materiales y documentos están normados por la presente política y están protegidos por derechos de propiedad intelectual y derechos de autor a favor del Icfes. Si tiene conocimiento de alguna utilización contraria a lo establecido en estas condiciones de uso, por favor infórmenos al correo prensaicfes@icfes.gov.co.

Queda prohibido el uso o publicación total o parcial de este material con fines de lucro. **Únicamente está autorizado su uso para fines académicos e investigativos**. Ninguna persona, natural o jurídica, nacional o internacional, podrá vender, distribuir, alquilar, reproducir, transformar*, promocionar o realizar acción alguna de la cual se lucre directa o indirectamente con este material. Esta publicación cuenta con el registro ISBN (International Standard Book Number, o Número Normalizado Internacional para Libros) que facilita la identificación no solo de cada título, sino de la autoría, la edición, el editor y el país en donde se edita.

En todo caso, cuando se haga uso parcial o total de los contenidos de esta publicación del Icfes, el usuario deberá consignar o hacer referencia a los créditos institucionales del Icfes respetando los derechos de cita; es decir, se podrán utilizar con los fines aquí previstos transcribiendo los pasajes necesarios, citando siempre al Icfes como fuente de autor. Lo anterior siempre que los pasajes no sean tantos y seguidos que razonadamente puedan considerarse como una reproducción simulada y sustancial, que redunde en perjuicio del Icfes.

Asimismo, los logotipos institucionales son marcas registradas y de propiedad exclusiva del Icfes. Por tanto, los terceros no podrán usar las marcas de propiedad del Icfes con signos idénticos o similares respecto de cualesquiera productos o servicios prestados por esta entidad, cuando su uso pueda causar confusión. En todo caso queda prohibido su uso sin previa autorización expresa del Icfes. La infracción de estos derechos se perseguirá civil y, en su caso, penalmente, de acuerdo con las leyes nacionales y tratados internacionales aplicables.

El Icfes realizará cambios o revisiones periódicas a los presentes términos de uso, y los actualizará en esta publicación.

El Icfes adelantará las acciones legales pertinentes por cualquier violación a estas políticas y condiciones de uso.

* La transformación es la modificación de la obra a través de la creación de adaptaciones, traducciones, compilaciones, actualizaciones, revisiones y, en general, cualquier modificación que de la obra se pueda realizar, de modo que la nueva obra resultante se constituya en una obra derivada protegida por el derecho de autor, con la única diferencia respecto de las obras originales de que aquellas requieren para su realización de la autorización expresa del autor o propietario para adaptar, traducir, compilar, etcétera. En este caso, el Icfes prohíbe la transformación de esta publicación.



SABER 9

SABER 9 - PRUEBA DE MATEMÁTICAS

• Pregunta 1.

La gráfica presenta el total nacional, en miles, de ocupados (personas con actividad laboral propia o externa), desocupados (personas sin actividad laboral propia o externa), empleados insatisfechos con su trabajo y empleados en proceso de cambio de trabajo de Colombia, durante los años 2009 y 2010.

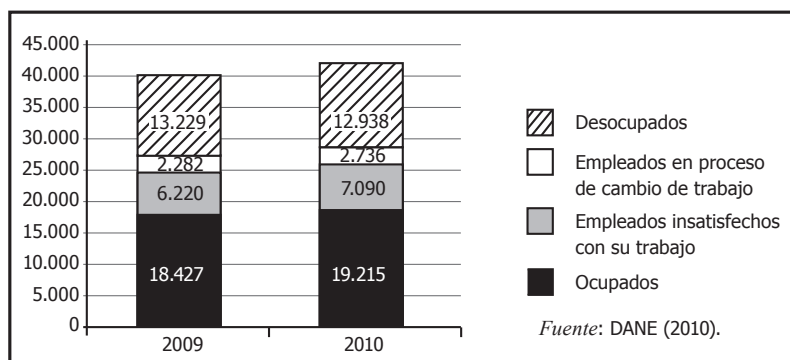

Gráfica

¿Cuál de las siguientes tablas representa correctamente la información anterior ?

A.

Año	Ocupados	Empleados insatisfechos con su trabajo	Empleados en proceso de cambio de trabajo	Desocupados
2009	13.229	2.282	6.220	18.427
2010	12.938	2.736	7.090	19.215

B.

Estado de actividad	Total
Ocupados	37.642
Empleados insatisfechos con su trabajo	13.310
Empleados en proceso de cambio de trabajo	5.018
Desocupados	26.167

C.

Año	Estado de actividad	Número de personas
2009	Ocupados	18.427
	Empleados insatisfechos con su trabajo	6.220
	Empleados en proceso de cambio de trabajo	2.282
	Desocupados	13.229
2010	Ocupados	19.215
	Empleados insatisfechos con su trabajo	7.090
	Empleados en proceso de cambio de trabajo	2.736
	Desocupados	12.938

D.

Estado de actividad	2009 (miles)	2010 (miles)
Ocupados	18	19
Empleados insatisfechos con su trabajo	6	7
Empleados en proceso de cambio de trabajo	2	2
Desocupados	13	12

• Estructura

Competencia	Comunicación
Componente	Aleatorio
Afirmación	Reconocer relaciones entre diferentes representaciones de un conjunto de datos y analizar la pertinencia de la representación.
Nivel de desempeño	Satisfactorio
Respuesta Correcta	C

• Resultados a nivel nacional y de Entidad Territorial Certificada (ETC)

ETC/País	A	B	C	D	Omisión y multimarca	Nº estudiantes
Amazonas	18.0%	18.2%	53.0%	8.3%	2.6%	627
Antioquia	17.2%	18.6%	54.3%	8.5%	1.5%	19243
Apartadó	22.4%	20.0%	46.6%	10.0%	0.9%	1088
Arauca	14.2%	16.4%	60.8%	8.3%	0.3%	1581
Armenia	14.6%	16.6%	60.8%	7.6%	0.5%	2587
Atlántico	20.3%	17.2%	51.4%	10.0%	1.1%	4931
Barrancabermeja	16.6%	17.2%	57.2%	8.2%	0.7%	1845
Barranquilla	17.1%	15.4%	59.2%	7.5%	0.8%	10591
Bello	17.0%	15.1%	60.1%	6.9%	1.0%	3032
Bogotá, D.C.	12.6%	13.8%	66.0%	7.0%	0.6%	62070
Bolívar	22.4%	18.3%	48.0%	9.9%	1.4%	7542
Boyacá	12.3%	15.7%	63.4%	8.2%	0.3%	7836
Bucaramanga	10.4%	13.2%	69.3%	6.5%	0.6%	4498
Buenaventura	22.2%	18.4%	47.9%	10.3%	1.1%	2785
Buga	16.9%	16.2%	56.4%	9.9%	0.5%	917
Caldas	15.8%	17.5%	57.5%	8.6%	0.5%	4430
Cali	15.2%	15.2%	61.0%	7.8%	0.8%	16580
Caquetá	15.9%	19.1%	54.9%	9.7%	0.5%	1658
Cartagena	20.5%	16.9%	53.7%	8.0%	1.0%	9657
Cartago	15.1%	14.9%	62.8%	6.9%	0.2%	1017
Casanare	15.1%	17.4%	59.0%	8.1%	0.5%	2177
Cauca	17.5%	17.7%	53.7%	10.0%	1.1%	8223
Cesar	19.9%	19.1%	50.6%	9.9%	0.5%	5409
Chocó	22.0%	19.2%	46.7%	10.9%	1.2%	2050
Chía	10.2%	12.3%	70.3%	6.8%	0.4%	1416
Ciénaga	26.0%	21.9%	42.3%	8.5%	1.3%	1059
Cundinamarca	12.4%	14.9%	64.5%	7.8%	0.5%	13371

Continúa en la siguiente página



ETC/País	A	B	C	D	Omisión y multimarca	N° estudiantes
Córdoba	21.0%	19.0%	48.4%	10.7%	0.9%	8943
Cúcuta	12.7%	14.7%	64.5%	7.3%	0.8%	5733
Dosquebradas	12.5%	15.5%	63.2%	8.4%	0.5%	1319
Duitama	9.4%	12.0%	72.7%	5.8%	0.2%	1251
Envigado	13.7%	13.7%	67.9%	4.2%	0.7%	1633
Facatativá	12.0%	14.5%	67.8%	5.4%	0.3%	1114
Florencia	15.9%	16.9%	58.1%	8.2%	0.9%	1382
Floridablanca	11.1%	11.8%	71.0%	5.4%	0.7%	1982
Fusagasugá	12.2%	14.1%	64.9%	8.2%	0.5%	1121
Girardot	17.8%	14.5%	58.0%	9.1%	0.7%	912
Girón	13.0%	15.8%	65.6%	5.5%	0.2%	1109
Guainía	10.9%	17.5%	56.8%	14.2%	0.5%	183
Guaviare	16.9%	17.1%	54.6%	11.0%	0.5%	621
Huila	14.1%	16.6%	60.0%	8.7%	0.6%	5194
Ibagué	13.5%	16.3%	62.5%	7.2%	0.4%	4714
Ipiales	12.9%	13.1%	66.4%	7.3%	0.3%	1066
Itagüí	21.9%	15.5%	54.6%	6.8%	1.2%	1746
Jamundí	16.1%	15.8%	59.0%	8.4%	0.7%	939
La Guajira	21.1%	18.7%	49.7%	9.7%	0.9%	2204
Lorica	23.3%	19.1%	46.8%	10.2%	0.5%	1329
Magangué	19.2%	16.4%	50.2%	13.0%	1.2%	1065
Magdalena	22.7%	20.0%	44.1%	12.1%	1.1%	5904
Maicao	20.5%	16.4%	50.1%	12.5%	0.6%	1178
Malambo	16.8%	15.8%	59.3%	7.5%	0.6%	786
Manizales	13.1%	15.8%	63.2%	7.5%	0.4%	2770
Medellín	17.1%	16.8%	57.4%	7.3%	1.4%	17124
Meta	15.9%	17.6%	57.4%	8.4%	0.7%	3789
Montería	18.0%	17.5%	54.2%	9.4%	0.9%	4177
Mosquera	10.8%	12.4%	68.7%	7.3%	0.8%	1158
Nariño	13.9%	16.5%	59.6%	9.1%	0.8%	6043
Neiva	12.3%	14.1%	66.1%	6.8%	0.7%	2951
Norte de Santander	14.0%	16.5%	62.0%	7.2%	0.4%	5090
Palmira	11.1%	13.9%	67.3%	7.2%	0.6%	2330
Pasto	11.4%	14.7%	65.4%	7.8%	0.7%	3211
Pereira	13.5%	17.5%	61.0%	7.6%	0.4%	3748
Piedecuesta	13.2%	14.6%	64.1%	7.0%	1.1%	1186
Pitalito	12.5%	14.9%	64.1%	7.8%	0.7%	1068
Popayán	11.6%	16.7%	63.6%	7.4%	0.7%	2459
Putumayo	14.6%	17.1%	59.2%	8.0%	1.1%	2703

Continúa en la siguiente página

ETC/País	A	B	C	D	Omisión y multimarca	Nº estudiantes
Quibdó	23.4%	18.6%	44.6%	10.7%	2.8%	1087
Quindío	16.6%	19.2%	55.3%	8.4%	0.5%	2038
Riohacha	18.8%	17.2%	53.5%	9.3%	1.2%	1341
Rionegro	10.4%	16.9%	65.9%	6.3%	0.5%	1086
Risaralda	17.3%	16.2%	57.3%	8.8%	0.4%	1936
Sabaneta	12.9%	15.5%	66.9%	3.8%	0.8%	496
Sahagún	18.4%	16.9%	49.6%	14.6%	0.6%	1079
San Andrés	24.8%	18.1%	46.9%	9.5%	0.8%	529
Santa Marta	19.5%	17.9%	52.4%	9.2%	1.1%	4355
Santander	12.3%	15.4%	65.1%	6.9%	0.3%	6430
Sincelejo	18.0%	16.3%	56.5%	8.5%	0.7%	2695
Soacha	14.7%	15.1%	61.7%	7.5%	1.0%	4802
Sogamoso	9.3%	11.1%	72.2%	6.9%	0.5%	1267
Soledad	16.6%	16.3%	57.0%	9.0%	1.0%	4099
Sucre	21.5%	17.7%	49.4%	10.8%	0.6%	5462
Tolima	17.2%	17.5%	55.1%	9.4%	0.8%	6959
Tuluá	14.8%	16.8%	60.2%	7.8%	0.5%	1832
Tumaco	24.9%	19.6%	41.6%	12.7%	1.3%	1334
Tunja	9.5%	13.7%	70.6%	6.1%	0.1%	1740
Turbo	25.4%	20.0%	43.6%	9.9%	1.0%	1254
Uribe	16.0%	21.2%	52.1%	9.8%	1.0%	307
Valle del Cauca	16.6%	16.6%	57.2%	9.1%	0.5%	6250
Valledupar	18.3%	16.4%	54.7%	10.0%	0.6%	4092
Vichada	17.1%	16.3%	55.4%	10.6%	0.5%	404
Villavicencio	13.3%	14.8%	64.2%	7.2%	0.4%	4110
Yopal	11.9%	16.8%	64.9%	6.3%	0.1%	1395
Yumbo	15.1%	15.4%	59.1%	9.7%	0.7%	894
Zipaquirá	8.7%	14.0%	71.9%	5.2%	0.2%	1155
Colombia	15.7%	16.1%	59.2%	8.2%	0.8%	381883

*Es posible que los porcentajes mostrados no sumen exactamente 100 debido a aproximaciones decimales.

• **Pregunta 2.**

La tabla muestra la frecuencia cardiaca, medida en latidos del corazón por minuto (lpm) de Pedro y Claudia, durante 6 minutos.

Minuto	1	2	3	4	5	6
Frecuencia cardiaca de Pedro (lpm)	64	65	62	65	67	66
Frecuencia cardiaca de Claudia (lpm)	65	66	62	64	66	65

Tabla

¿Cuál de las siguientes gráficas representa correctamente la frecuencia cardiaca de Pedro y Claudia durante los 6 minutos?

----- Frecuencia cardiaca de Pedro
 _____ Frecuencia cardiaca de Claudia

A.

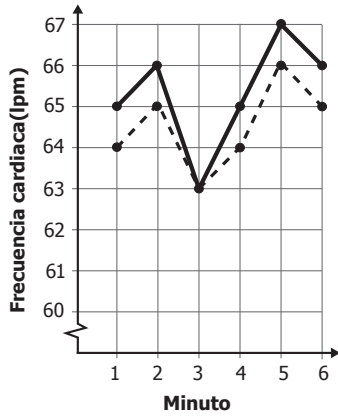

B.

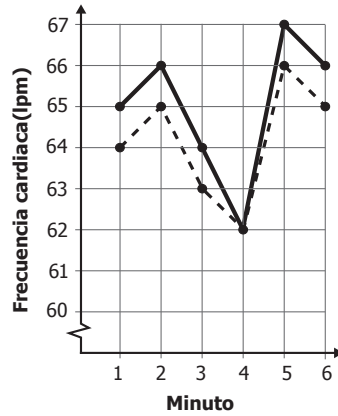

C.

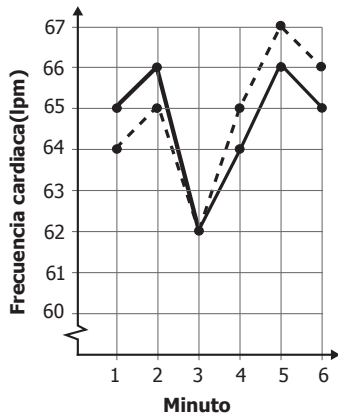

D.

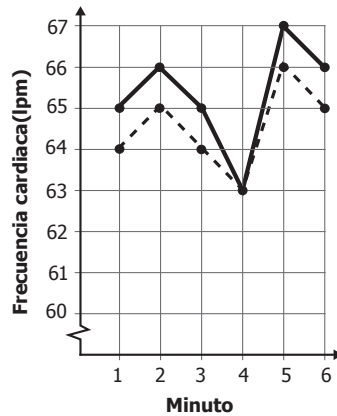

• Estructura

Competencia	Comunicación
Componente	Numérico - variacional
Afirmación	Establece relaciones entre propiedades de las graficas y propiedades de las ecuaciones algebraicas.
Nivel de desempeño	Mínimo
Respuesta Correcta	C

• Resultados a nivel nacional y de Entidad Territorial Certificada (ETC)

ETC/País	A	B	C	D	Omisión y multimarca	N° estudiantes
Amazonas	8.9%	14.4%	67.6%	6.5%	2.6%	627
Antioquia	7.1%	12.3%	74.0%	5.3%	1.4%	19243
Apartadó	9.7%	13.3%	70.2%	6.1%	0.6%	1088
Arauca	4.9%	9.7%	80.5%	4.6%	0.3%	1581
Armenia	6.9%	9.9%	79.2%	3.4%	0.5%	2587
Atlántico	9.1%	14.3%	69.1%	6.3%	1.2%	4931
Barrancabermeja	6.1%	11.5%	78.0%	3.5%	0.8%	1845
Barranquilla	7.1%	10.0%	78.4%	3.9%	0.6%	10591
Bello	6.8%	9.8%	78.0%	4.3%	1.1%	3032
Bogotá, D.C.	4.6%	6.7%	85.6%	2.6%	0.6%	62070
Bolívar	9.7%	16.8%	65.7%	6.5%	1.3%	7542
Boyacá	5.3%	6.8%	84.4%	3.2%	0.3%	7836
Bucaramanga	4.5%	5.6%	86.7%	2.6%	0.6%	4498
Buenaventura	9.9%	16.8%	65.7%	6.2%	1.3%	2785
Buga	4.6%	11.9%	79.6%	3.6%	0.3%	917
Caldas	7.3%	10.5%	77.0%	4.9%	0.4%	4430
Cali	6.9%	9.7%	78.8%	3.8%	0.8%	16580
Caquetá	7.4%	11.5%	75.3%	5.6%	0.3%	1658
Cartagena	9.2%	14.0%	70.7%	5.2%	0.9%	9657
Cartago	5.1%	8.7%	81.4%	4.5%	0.3%	1017
Casanare	4.7%	7.8%	83.8%	3.3%	0.4%	2177
Cauca	8.4%	12.3%	71.9%	6.3%	1.0%	8223
Cesar	7.4%	13.1%	73.2%	5.9%	0.4%	5409
Chocó	10.3%	18.8%	61.1%	8.5%	1.2%	2050
Chía	4.4%	4.5%	88.3%	2.4%	0.4%	1416
Ciénaga	10.6%	18.3%	62.3%	7.4%	1.4%	1059
Cundinamarca	4.7%	6.6%	85.2%	3.1%	0.4%	13371

Continúa en la siguiente página



ETC/País	A	B	C	D	Omisión y multimarca	N° estudiantes
Córdoba	9.2%	16.7%	66.0%	7.2%	0.9%	8943
Cúcuta	5.4%	7.2%	83.6%	3.2%	0.6%	5733
Dosquebradas	5.7%	5.7%	84.0%	4.2%	0.4%	1319
Duitama	4.6%	3.8%	89.8%	1.6%	0.2%	1251
Envigado	5.5%	7.8%	83.3%	2.7%	0.7%	1633
Facatativá	4.1%	6.0%	86.6%	2.8%	0.4%	1114
Florencia	6.0%	8.0%	81.4%	3.5%	1.0%	1382
Floridablanca	3.7%	5.9%	86.9%	2.8%	0.7%	1982
Fusagasugá	7.3%	6.2%	83.8%	2.2%	0.5%	1121
Girardot	6.7%	9.4%	79.2%	3.9%	0.8%	912
Girón	4.2%	6.9%	85.4%	3.2%	0.3%	1109
Guainía	7.1%	10.4%	77.0%	4.4%	1.1%	183
Guaviare	7.6%	10.0%	78.4%	3.7%	0.3%	621
Huila	6.1%	7.3%	82.7%	3.4%	0.4%	5194
Ibagué	5.3%	7.6%	83.4%	3.3%	0.4%	4714
Ipiales	6.0%	5.8%	85.8%	2.3%	0.1%	1066
Itagüí	7.4%	13.2%	73.3%	4.9%	1.3%	1746
Jamundí	6.0%	10.9%	77.7%	5.1%	0.3%	939
La Guajira	10.2%	16.7%	66.0%	6.6%	0.5%	2204
Lorica	9.6%	17.7%	64.9%	7.0%	0.8%	1329
Magangué	9.0%	14.3%	69.4%	5.9%	1.4%	1065
Magdalena	9.5%	16.9%	64.0%	8.3%	1.3%	5904
Maicao	9.8%	12.9%	70.5%	6.2%	0.6%	1178
Malambo	8.9%	11.7%	73.3%	5.5%	0.6%	786
Manizales	6.3%	8.3%	81.3%	3.6%	0.4%	2770
Medellín	6.9%	11.1%	76.3%	4.3%	1.3%	17124
Meta	6.0%	9.5%	80.1%	3.8%	0.6%	3789
Montería	7.4%	12.6%	74.1%	5.0%	0.9%	4177
Mosquera	4.1%	5.4%	87.7%	2.3%	0.3%	1158
Nariño	5.5%	9.3%	80.6%	3.8%	0.8%	6043
Neiva	4.3%	6.5%	86.4%	2.3%	0.5%	2951
Norte de Santander	5.8%	9.0%	81.3%	3.5%	0.5%	5090
Palmira	4.8%	6.4%	84.8%	3.3%	0.7%	2330
Pasto	4.3%	5.6%	86.9%	2.5%	0.7%	3211
Pereira	5.9%	7.4%	83.3%	3.1%	0.4%	3748
Piedecuesta	6.1%	9.4%	80.9%	2.7%	0.9%	1186
Pitalito	5.7%	6.5%	84.4%	2.8%	0.7%	1068
Popayán	5.0%	6.9%	84.5%	2.9%	0.8%	2459
Putumayo	5.9%	8.8%	80.9%	3.5%	0.9%	2703

Continúa en la siguiente página

ETC/País	A	B	C	D	Omisión y multimarca	N° estudiantes
Quibdó	10.6%	19.5%	59.8%	7.5%	2.7%	1087
Quindío	6.8%	10.0%	78.5%	4.3%	0.4%	2038
Riohacha	7.5%	12.8%	72.4%	6.1%	1.1%	1341
Rionegro	6.5%	6.6%	84.2%	2.3%	0.4%	1086
Risaralda	6.2%	9.8%	78.8%	4.9%	0.3%	1936
Sabaneta	3.4%	6.9%	85.3%	3.6%	0.8%	496
Sahagún	6.9%	10.4%	77.2%	5.2%	0.4%	1079
San Andrés	8.5%	16.8%	67.3%	6.8%	0.6%	529
Santa Marta	8.0%	13.6%	71.0%	6.1%	1.3%	4355
Santander	4.8%	6.8%	84.9%	3.1%	0.3%	6430
Sincelejo	8.5%	13.2%	73.0%	4.7%	0.5%	2695
Soacha	6.1%	8.7%	81.0%	3.2%	1.0%	4802
Sogamoso	4.6%	4.9%	87.8%	2.3%	0.4%	1267
Soledad	7.6%	11.0%	76.3%	4.1%	1.0%	4099
Sucre	9.5%	15.8%	67.3%	6.8%	0.7%	5462
Tolima	6.8%	11.3%	76.1%	5.0%	0.8%	6959
Tuluá	5.6%	9.5%	80.8%	3.6%	0.5%	1832
Tumaco	12.1%	18.1%	60.0%	8.5%	1.3%	1334
Tunja	4.5%	4.9%	87.6%	2.8%	0.2%	1740
Turbo	9.8%	19.2%	62.9%	6.5%	1.5%	1254
Uribe	10.7%	11.1%	72.3%	5.2%	0.7%	307
Valle del Cauca	6.4%	10.4%	77.9%	4.9%	0.4%	6250
Valledupar	7.6%	13.1%	74.0%	4.9%	0.5%	4092
Vichada	7.9%	11.1%	73.0%	7.2%	0.7%	404
Villavicencio	5.6%	8.0%	83.4%	2.7%	0.4%	4110
Yopal	5.7%	6.2%	85.5%	2.6%	0.1%	1395
Yumbo	6.5%	9.5%	80.2%	3.4%	0.4%	894
Zipaquirá	2.7%	5.7%	89.4%	2.1%	0.2%	1155
Colombia	6.5%	10.0%	78.6%	4.2%	0.7%	381883

*Es posible que los porcentajes mostrados no sumen exactamente 100 debido a aproximaciones decimales.

• **Pregunta 3.**

La gráfica muestra la variación porcentual mensual de ventas del comercio minorista en una ciudad.

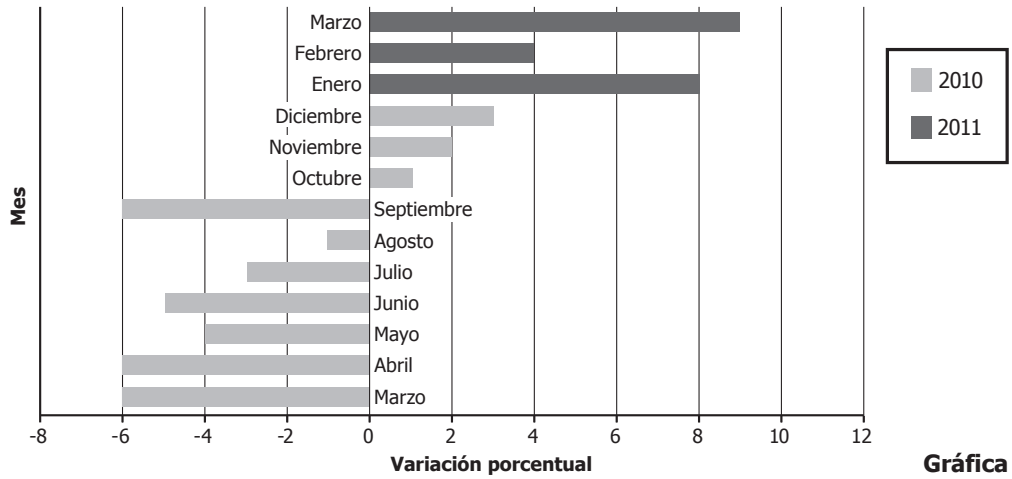

La tabla que representa correctamente la información de la gráfica es

A.

2010		2011	
Mes	Variación porcentual	Mes	Variación porcentual
Marzo	6	Enero	8
Abril	6	Febrero	4
Mayo	4	Marzo	9
Junio	5		
Julio	3		
Agosto	1		
Septiembre	6		
Octubre	1		
Noviembre	2		
Diciembre	3		

B.

2010		2011	
Mes	Variación porcentual	Mes	Variación porcentual
Marzo	6	Enero	-8
Abril	6	Febrero	-4
Mayo	4	Marzo	-9
Junio	5		
Julio	3		
Agosto	1		
Septiembre	6		
Octubre	-1		
Noviembre	-2		
Diciembre	-3		

C.

2010		2011	
Mes	Variación porcentual	Mes	Variación porcentual
Marzo	-6	Enero	8
Abril	-6	Febrero	4
Mayo	-4	Marzo	9
Junio	-5		
Julio	-3		
Agosto	-1		
Septiembre	-6		
Octubre	1		
Noviembre	2		
Diciembre	3		

D.

2010		2011	
Mes	Variación porcentual	Mes	Variación porcentual
Marzo	-6	Enero	-8
Abril	-6	Febrero	-4
Mayo	-4	Marzo	-9
Junio	-5		
Julio	-3		
Agosto	-1		
Septiembre	-6		
Octubre	-1		
Noviembre	-2		
Diciembre	-3		

• Estructura

Competencia	Comunicación
Componente	Aleatorio
Afirmación	Reconocer relaciones entre diferentes representaciones de un conjunto de datos y analizar la pertinencia a la representación.
Nivel de desempeño	Mínimo
Respuesta Correcta	C

• Resultados a nivel nacional y de Entidad Territorial Certificada (ETC)

ETC	A	B	C	D	Omisión y multimarca	Nº estudiantes
Amazonas	13.2%	15.5%	60.1%	8.3%	2.9%	627
Antioquia	12.7%	13.6%	65.0%	7.1%	1.7%	19243
Apartadó	14.4%	15.2%	61.2%	8.2%	1.0%	1088
Arauca	10.2%	10.6%	73.3%	5.4%	0.4%	1581
Armenia	10.3%	11.8%	70.5%	6.4%	1.0%	2587
Atlántico	15.7%	14.9%	59.5%	8.4%	1.6%	4931
Barrancabermeja	11.2%	10.8%	71.0%	6.1%	0.9%	1845
Barranquilla	11.0%	11.2%	70.5%	6.2%	1.1%	10591
Bello	10.2%	12.7%	69.4%	6.4%	1.3%	3032
Bogotá, D.C.	7.6%	9.1%	78.3%	4.3%	0.8%	62070
Bolívar	16.7%	16.6%	56.0%	8.7%	2.0%	7542
Boyacá	9.3%	9.2%	75.8%	5.3%	0.4%	7836
Bucaramanga	6.7%	7.4%	80.8%	4.3%	0.8%	4498
Buenaventura	17.1%	15.4%	56.7%	9.0%	1.8%	2785
Buga	9.8%	9.4%	73.2%	6.5%	1.1%	917
Caldas	12.3%	12.5%	67.8%	6.7%	0.7%	4430
Cali	10.0%	11.3%	72.0%	5.6%	1.1%	16580
Caquetá	12.1%	13.2%	65.5%	8.6%	0.6%	1658
Cartagena	13.1%	14.6%	63.9%	7.1%	1.2%	9657
Cartago	8.2%	9.8%	74.7%	6.4%	0.9%	1017
Casanare	9.6%	9.8%	74.8%	5.1%	0.7%	2177
Cauca	14.1%	15.0%	61.4%	8.0%	1.4%	8223
Cesar	14.9%	15.0%	62.0%	7.6%	0.6%	5409
Chocó	20.1%	15.9%	53.0%	9.3%	1.7%	2050
Chía	7.0%	6.2%	83.1%	3.3%	0.4%	1416
Ciénaga	18.0%	16.7%	52.2%	11.1%	1.9%	1059

Continúa en la siguiente página



ETC	A	B	C	D	Omisión y multimarca	N° estudiantes
Cundinamarca	8.4%	9.2%	77.5%	4.3%	0.7%	13371
Córdoba	16.7%	16.2%	56.5%	9.4%	1.2%	8943
Cúcuta	8.1%	9.3%	77.0%	4.6%	0.9%	5733
Dosquebradas	8.3%	9.2%	76.6%	5.2%	0.6%	1319
Duitama	6.2%	7.7%	82.8%	3.4%	0.0%	1251
Envigado	7.3%	9.7%	78.6%	3.4%	0.9%	1633
Facatativá	7.0%	7.9%	81.1%	3.4%	0.5%	1114
Florencia	9.7%	10.1%	73.6%	5.1%	1.4%	1382
Floridablanca	5.4%	7.8%	82.3%	3.3%	1.1%	1982
Fusagasugá	7.9%	9.5%	77.3%	4.4%	0.8%	1121
Girardot	12.5%	11.8%	69.5%	5.2%	1.0%	912
Girón	9.2%	9.6%	76.0%	5.0%	0.3%	1109
Guainía	7.1%	14.8%	72.1%	5.5%	0.5%	183
Guaviare	11.1%	12.1%	68.8%	7.4%	0.6%	621
Huila	10.5%	11.6%	71.9%	5.2%	0.7%	5194
Ibagué	8.9%	10.2%	74.8%	5.3%	0.7%	4714
Ipiales	8.4%	8.7%	78.8%	3.8%	0.2%	1066
Itagüí	10.6%	14.5%	66.7%	6.7%	1.4%	1746
Jamundí	9.7%	11.4%	72.1%	6.0%	0.9%	939
La Guajira	17.1%	16.9%	56.6%	8.5%	1.0%	2204
Lorica	16.7%	19.3%	52.5%	10.6%	0.9%	1329
Magangué	13.1%	15.5%	61.5%	8.3%	1.7%	1065
Magdalena	17.8%	17.6%	53.6%	9.5%	1.6%	5904
Maicao	14.9%	14.8%	60.7%	8.7%	0.9%	1178
Malambo	14.1%	13.6%	64.5%	6.5%	1.3%	786
Manizales	12.1%	10.4%	71.2%	5.6%	0.8%	2770
Medellín	11.1%	12.5%	68.9%	6.0%	1.6%	17124
Meta	10.2%	11.5%	71.5%	5.9%	0.8%	3789
Montería	13.4%	14.1%	64.6%	6.5%	1.3%	4177
Mosquera	6.5%	7.2%	81.5%	4.2%	0.6%	1158
Nariño	10.6%	11.5%	71.1%	5.8%	1.0%	6043
Neiva	7.7%	8.5%	79.4%	3.7%	0.7%	2951
Norte de Santander	10.0%	10.6%	73.6%	5.1%	0.8%	5090
Palmira	7.3%	9.3%	78.5%	4.2%	0.7%	2330
Pasto	8.2%	8.6%	78.7%	3.7%	0.7%	3211
Pereira	9.7%	8.9%	75.5%	5.3%	0.5%	3748
Piedecuesta	8.9%	9.4%	75.1%	5.3%	1.3%	1186
Pitalito	8.6%	10.2%	77.0%	3.3%	0.9%	1068
Popayán	9.3%	9.2%	74.7%	5.8%	1.1%	2459

Continúa en la siguiente página

ETC	A	B	C	D	Omisión y multimarca	N° estudiantes
Putumayo	8.9%	10.8%	73.7%	5.4%	1.2%	2703
Quibdó	17.8%	18.9%	49.5%	10.7%	3.1%	1087
Quindío	11.9%	13.1%	68.4%	5.9%	0.7%	2038
Riohacha	13.0%	15.3%	63.4%	6.9%	1.4%	1341
Rionegro	8.5%	9.7%	76.8%	4.4%	0.6%	1086
Risaralda	12.0%	13.3%	67.5%	6.7%	0.6%	1936
Sabaneta	7.5%	11.1%	74.4%	5.8%	1.2%	496
Sahagún	13.5%	14.5%	64.5%	7.0%	0.6%	1079
San Andrés	14.0%	15.5%	56.9%	11.9%	1.7%	529
Santa Marta	14.0%	13.6%	62.2%	8.4%	1.7%	4355
Santander	9.2%	8.7%	77.1%	4.5%	0.6%	6430
Sincelejo	12.9%	14.2%	65.3%	6.9%	0.8%	2695
Soacha	9.2%	10.5%	73.7%	5.2%	1.3%	4802
Sogamoso	5.5%	6.9%	83.5%	3.8%	0.3%	1267
Soledad	12.0%	10.8%	69.9%	6.0%	1.4%	4099
Sucre	16.0%	16.1%	57.9%	9.0%	1.0%	5462
Tolima	12.5%	13.4%	66.0%	7.2%	0.9%	6959
Tuluá	11.7%	10.6%	71.9%	5.0%	0.8%	1832
Tumaco	16.3%	18.8%	52.1%	10.6%	2.2%	1334
Tunja	7.0%	8.7%	81.4%	2.8%	0.1%	1740
Turbo	17.3%	15.9%	55.5%	9.9%	1.4%	1254
Uribe	12.1%	13.4%	66.4%	6.5%	1.6%	307
Valle del Cauca	12.2%	13.0%	67.5%	6.4%	0.9%	6250
Valledupar	12.8%	13.0%	66.5%	6.8%	0.9%	4092
Vichada	15.6%	16.1%	59.9%	7.4%	1.0%	404
Villavicencio	7.3%	10.0%	77.8%	4.2%	0.7%	4110
Yopal	7.6%	8.7%	79.0%	4.4%	0.2%	1395
Yumbo	12.0%	12.0%	69.8%	5.4%	0.9%	894
Zipaquirá	6.8%	6.8%	82.6%	3.3%	0.5%	1155
Colombia	10.9%	11.7%	70.4%	6.0%	1.0%	381883

*Es posible que los porcentajes mostrados no sumen exactamente 100 debido a aproximaciones decimales.

• **Pregunta 4.**

La gráfica representa las variaciones en el peso ideal y el peso real (en libras), de un animal, durante sus 8 primeras semanas de vida.

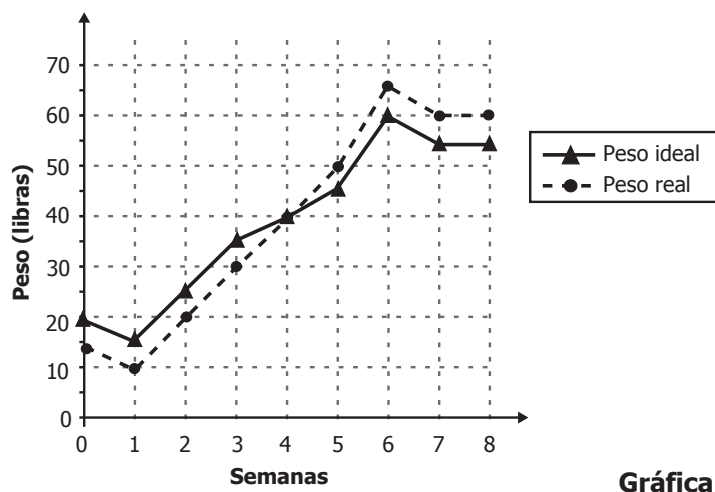

¿En qué semana, el peso real del animal fue igual al peso ideal?

- A. 1
- B. 4
- C. 6
- D. 8

• **Estructura**

Competencia	Comunicación
Componente	Numérico - variacional
Afirmación	Establece relaciones entre propiedades de las graficas y propiedades de las ecuaciones algebraicas.
Nivel de desempeño	Mínimo
Respuesta Correcta	B

• Resultados a nivel nacional y de Entidad Territorial Certificada (ETC)

ETC/País	A	B	C	D	Omisión y multimarca	N° estudiantes
Amazonas	4.9%	57.4%	12.4%	22.5%	2.7%	627
Antioquia	5.8%	67.6%	10.3%	14.7%	1.7%	19243
Apartadó	7.7%	61.4%	11.9%	17.9%	1.1%	1088
Arauca	4.4%	76.0%	7.8%	11.3%	0.4%	1581
Armenia	4.6%	75.3%	9.5%	10.1%	0.5%	2587
Atlántico	6.9%	62.8%	11.6%	17.0%	1.7%	4931
Barrancabermeja	5.0%	72.0%	10.0%	12.4%	0.7%	1845
Barranquilla	5.9%	72.1%	9.1%	12.1%	0.8%	10591
Bello	5.5%	74.2%	8.6%	10.4%	1.3%	3032
Bogotá, D.C.	3.2%	82.0%	6.4%	7.8%	0.6%	62070
Bolívar	8.5%	55.7%	13.5%	20.6%	1.7%	7542
Boyacá	3.2%	80.2%	6.2%	9.9%	0.4%	7836
Bucaramanga	3.3%	83.5%	5.3%	7.2%	0.7%	4498
Buenaventura	7.9%	56.9%	12.9%	20.8%	1.5%	2785
Buga	6.9%	77.8%	6.7%	8.3%	0.4%	917
Caldas	4.5%	71.1%	9.3%	14.7%	0.5%	4430
Cali	5.0%	74.4%	8.5%	11.0%	1.0%	16580
Caquetá	5.1%	70.0%	9.4%	14.8%	0.7%	1658
Cartagena	8.0%	63.7%	11.7%	15.3%	1.3%	9657
Cartago	4.3%	76.5%	7.1%	11.9%	0.2%	1017
Casanare	3.8%	77.8%	6.9%	10.8%	0.7%	2177
Cauca	5.9%	63.9%	11.6%	17.4%	1.2%	8223
Cesar	6.9%	64.1%	11.5%	17.0%	0.5%	5409
Chocó	9.1%	54.7%	13.0%	21.7%	1.6%	2050
Chía	2.8%	86.2%	4.4%	6.4%	0.3%	1416
Ciénaga	8.3%	53.9%	14.5%	21.3%	1.9%	1059
Cundinamarca	2.9%	81.3%	6.3%	8.9%	0.5%	13371
Córdoba	8.2%	60.4%	12.1%	18.2%	1.2%	8943
Cúcuta	4.6%	78.2%	6.5%	9.9%	0.8%	5733
Dosquebradas	4.2%	80.1%	8.3%	7.1%	0.4%	1319
Duitama	1.8%	88.2%	4.2%	5.4%	0.2%	1251
Envigado	4.0%	80.3%	7.8%	7.2%	0.7%	1633
Facatativá	2.0%	83.5%	5.4%	8.6%	0.5%	1114
Florencia	4.6%	77.5%	7.7%	9.5%	0.7%	1382
Floridablanca	2.9%	85.4%	4.4%	6.4%	0.9%	1982
Fusagasugá	4.1%	81.2%	5.6%	8.4%	0.7%	1121
Girardot	4.9%	71.3%	9.2%	13.6%	1.0%	912

Continúa en la siguiente página



ETC/País	A	B	C	D	Omisión y multimarca	N° estudiantes
Girón	4.3%	78.6%	7.6%	9.4%	0.1%	1109
Guainía	3.8%	69.9%	10.4%	14.2%	1.6%	183
Guaviare	5.0%	73.6%	9.8%	11.3%	0.3%	621
Huila	3.9%	75.6%	8.0%	12.1%	0.6%	5194
Ibagué	4.1%	78.1%	7.0%	10.2%	0.5%	4714
Ipiales	2.3%	83.9%	7.0%	6.8%	0.1%	1066
Itagüí	6.5%	66.3%	11.7%	14.2%	1.2%	1746
Jamundí	5.3%	70.8%	9.7%	13.6%	0.5%	939
La Guajira	7.7%	58.1%	14.3%	19.1%	0.7%	2204
Lorica	9.0%	57.4%	11.1%	21.6%	0.9%	1329
Magangué	6.7%	63.7%	10.9%	17.2%	1.6%	1065
Magdalena	9.4%	55.4%	13.3%	20.3%	1.5%	5904
Maicao	8.7%	61.6%	11.7%	17.3%	0.6%	1178
Malambo	6.9%	66.3%	12.3%	13.9%	0.6%	786
Manizales	3.6%	77.4%	7.6%	10.9%	0.5%	2770
Medellín	5.9%	71.4%	9.3%	11.8%	1.6%	17124
Meta	4.2%	75.0%	9.2%	10.8%	0.8%	3789
Montería	6.1%	68.1%	11.1%	13.7%	1.0%	4177
Mosquera	3.1%	85.1%	3.5%	7.9%	0.4%	1158
Nariño	4.1%	75.5%	7.7%	11.8%	0.8%	6043
Neiva	3.4%	80.8%	5.4%	9.6%	0.8%	2951
Norte de Santander	5.1%	75.7%	7.2%	11.4%	0.6%	5090
Palmira	2.9%	79.4%	7.6%	9.4%	0.7%	2330
Pasto	3.0%	81.5%	6.0%	8.8%	0.7%	3211
Pereira	4.0%	79.2%	7.0%	9.3%	0.4%	3748
Piedecuesta	4.2%	80.1%	6.5%	8.1%	1.1%	1186
Pitalito	3.4%	80.4%	6.1%	9.4%	0.7%	1068
Popayán	3.8%	79.1%	6.7%	9.5%	1.0%	2459
Putumayo	4.1%	75.2%	8.6%	11.0%	1.0%	2703
Quibdó	11.6%	49.8%	14.2%	20.8%	3.7%	1087
Quindío	4.7%	71.8%	10.1%	12.8%	0.6%	2038
Riohacha	7.8%	65.8%	10.1%	15.2%	1.1%	1341
Rionegro	5.2%	79.7%	6.6%	8.0%	0.6%	1086
Risaralda	4.4%	74.0%	8.4%	12.7%	0.6%	1936
Sabaneta	4.0%	80.4%	6.3%	8.3%	1.0%	496
Sahagún	7.0%	69.2%	9.3%	13.8%	0.7%	1079
San Andrés	9.1%	59.5%	16.1%	14.9%	0.4%	529
Santa Marta	7.9%	65.3%	10.8%	14.6%	1.4%	4355
Santander	3.3%	81.5%	5.9%	9.0%	0.3%	6430

Continúa en la siguiente página

ETC/País	A	B	C	D	Omisión y multimarca	N° estudiantes
Sincelejo	6.6%	68.2%	10.6%	13.9%	0.6%	2695
Soacha	4.4%	76.6%	8.2%	9.8%	1.1%	4802
Sogamoso	2.1%	87.5%	5.0%	5.1%	0.5%	1267
Soledad	6.7%	69.9%	9.5%	12.8%	1.1%	4099
Sucre	7.3%	60.5%	12.3%	19.1%	0.8%	5462
Tolima	5.3%	67.3%	10.2%	16.2%	1.0%	6959
Tuluá	5.3%	73.9%	7.6%	12.4%	0.7%	1832
Tumaco	10.0%	49.1%	14.2%	25.0%	1.7%	1334
Tunja	3.0%	86.0%	4.2%	6.8%	0.1%	1740
Turbo	7.4%	55.3%	14.7%	21.1%	1.5%	1254
Uribe	6.5%	52.8%	9.4%	30.3%	1.0%	307
Valle del Cauca	5.4%	70.8%	9.8%	13.5%	0.6%	6250
Valledupar	6.7%	67.3%	10.7%	14.5%	0.8%	4092
Vichada	5.2%	70.5%	7.7%	15.6%	1.0%	404
Villavicencio	3.7%	81.0%	6.4%	8.3%	0.6%	4110
Yopal	2.3%	81.4%	6.2%	9.6%	0.5%	1395
Yumbo	6.0%	73.8%	7.3%	12.2%	0.7%	894
Zipaquirá	2.4%	86.5%	3.4%	7.4%	0.3%	1155
Colombia	5.1%	73.2%	8.7%	12.1%	0.9%	381883

*Es posible que los porcentajes mostrados no sumen exactamente 100 debido a aproximaciones decimales.

• **Pregunta 5.**

* A continuación se presenta una figura geométrica y las medidas de sus lados.

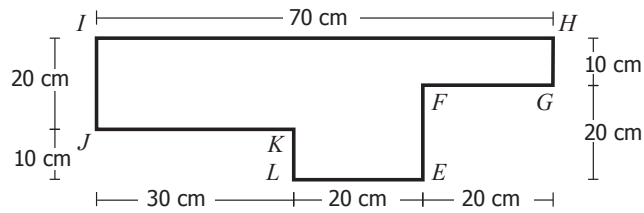

Figura

La figura se representó en diferentes sistemas de coordenadas cartesianas.

¿En cuál de las siguientes representaciones, la escala permite leer todas las medidas de los lados de la figura?

A.

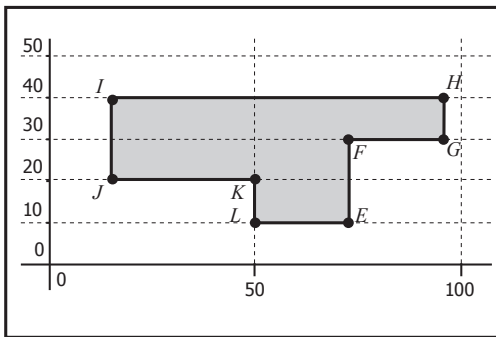

B.

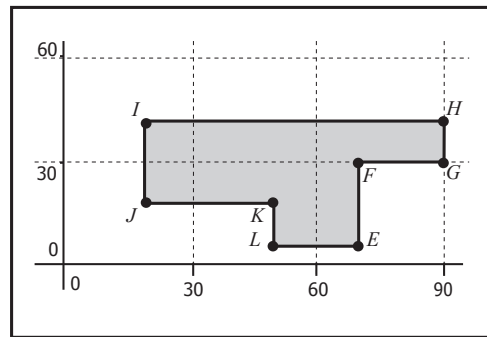

C.

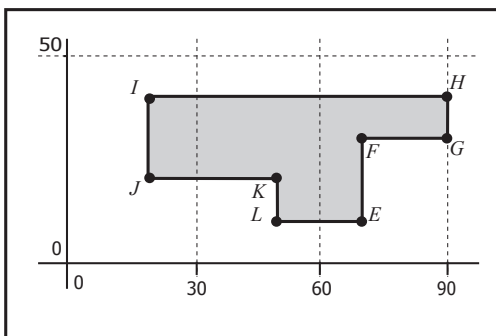

D.

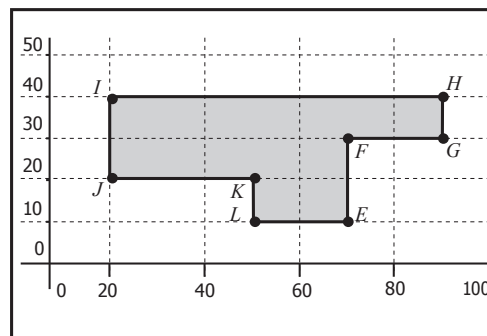

• Estructura

Competencia	Comunicación
Componente	Espacial - métrico
Afirmación	Identificar características de localización de objetos en sistemas de representación cartesiana y geográfica.
Nivel de desempeño	Satisfactorio
Respuesta Correcta	D

• Resultados a nivel nacional y de Entidad Territorial Certificada (ETC)

ETC/País	A	B	C	D	Omisión y multimarca	Nº estudiantes
Amazonas	28.1%	11.0%	6.7%	51.8%	2.4%	627
Antioquia	26.4%	13.6%	9.0%	49.4%	1.6%	19243
Apartadó	29.0%	16.5%	10.0%	43.5%	1.1%	1088
Arauca	25.7%	10.9%	7.8%	55.3%	0.3%	1581
Armenia	27.2%	12.3%	7.0%	52.8%	0.7%	2587
Atlántico	29.7%	15.0%	9.7%	44.3%	1.3%	4931
Barrancabermeja	25.6%	12.0%	6.8%	54.7%	0.9%	1845
Barranquilla	27.7%	12.8%	8.1%	50.2%	1.2%	10591
Bello	27.7%	13.1%	7.6%	50.0%	1.6%	3032
Bogotá, D.C.	22.7%	9.7%	6.0%	60.7%	0.8%	62070
Bolívar	30.9%	15.4%	9.8%	42.3%	1.5%	7542
Boyacá	24.1%	10.1%	6.3%	59.1%	0.4%	7836
Bucaramanga	22.4%	9.0%	5.4%	62.1%	1.1%	4498
Buenaventura	33.6%	14.1%	8.9%	41.6%	1.8%	2785
Buga	26.3%	11.9%	7.6%	53.9%	0.3%	917
Caldas	28.1%	12.1%	8.3%	51.1%	0.4%	4430
Cali	25.5%	11.7%	7.0%	54.7%	1.1%	16580
Caquetá	26.8%	13.3%	8.3%	50.8%	0.9%	1658
Cartagena	29.8%	14.4%	8.7%	45.7%	1.3%	9657
Cartago	27.3%	10.2%	4.8%	57.3%	0.3%	1017
Casanare	24.3%	10.2%	6.7%	58.5%	0.4%	2177
Cauca	27.8%	13.4%	8.3%	49.3%	1.3%	8223
Cesar	29.9%	14.2%	8.8%	46.6%	0.5%	5409
Chocó	32.2%	16.0%	10.7%	40.0%	1.1%	2050
Chía	18.4%	7.3%	4.8%	68.9%	0.6%	1416
Ciénaga	32.0%	16.3%	10.0%	40.3%	1.3%	1059

Continúa en la siguiente página



ETC/País	A	B	C	D	Omisión y multimarca	N° estudiantes
Cundinamarca	23.3%	10.2%	6.6%	59.2%	0.6%	13371
Córdoba	30.3%	14.9%	9.8%	44.0%	1.0%	8943
Cúcuta	26.0%	11.2%	6.4%	55.6%	0.9%	5733
Dosquebradas	23.6%	10.2%	5.6%	60.0%	0.6%	1319
Duitama	20.3%	7.9%	4.0%	67.7%	0.1%	1251
Envigado	20.8%	9.2%	6.3%	62.8%	0.9%	1633
Facatativá	23.7%	8.6%	5.5%	61.7%	0.5%	1114
Florencia	24.3%	13.5%	6.2%	55.4%	0.7%	1382
Floridablanca	21.1%	10.4%	5.2%	62.2%	1.1%	1982
Fusagasugá	22.8%	10.0%	5.4%	61.1%	0.7%	1121
Girardot	28.9%	13.5%	7.5%	49.2%	0.9%	912
Girón	26.3%	10.9%	6.1%	56.4%	0.2%	1109
Guainía	23.5%	10.4%	7.1%	57.9%	1.1%	183
Guaviare	25.0%	11.0%	9.3%	54.6%	0.2%	621
Huila	24.7%	10.7%	7.3%	56.6%	0.7%	5194
Ibagué	23.4%	11.7%	7.2%	57.1%	0.7%	4714
Ipiales	21.2%	11.2%	5.9%	61.5%	0.2%	1066
Itagüí	29.8%	14.2%	9.2%	45.3%	1.5%	1746
Jamundí	27.5%	12.2%	6.3%	53.4%	0.6%	939
La Guajira	30.0%	16.0%	10.3%	42.7%	0.9%	2204
Lorica	31.6%	14.7%	11.0%	42.1%	0.5%	1329
Magangué	29.5%	14.3%	8.1%	46.3%	1.9%	1065
Magdalena	31.4%	14.8%	10.5%	42.0%	1.4%	5904
Maicao	31.2%	16.1%	9.1%	43.0%	0.6%	1178
Malambo	28.8%	12.1%	8.9%	49.2%	1.0%	786
Manizales	25.2%	10.9%	7.3%	56.1%	0.5%	2770
Medellín	26.5%	12.8%	7.8%	51.3%	1.5%	17124
Meta	24.6%	12.1%	7.3%	55.2%	0.8%	3789
Montería	28.5%	13.5%	7.9%	48.7%	1.3%	4177
Mosquera	19.8%	8.6%	6.6%	64.0%	0.9%	1158
Nariño	24.4%	11.8%	7.4%	55.5%	0.9%	6043
Neiva	25.9%	9.6%	5.1%	58.7%	0.8%	2951
Norte de Santander	24.8%	12.5%	7.2%	54.7%	0.8%	5090
Palmira	23.4%	9.2%	5.2%	61.4%	0.9%	2330
Pasto	22.0%	10.6%	6.7%	59.7%	1.0%	3211
Pereira	25.5%	10.1%	6.5%	57.3%	0.6%	3748
Piedecuesta	23.9%	13.6%	7.8%	53.7%	1.0%	1186
Pitalito	24.3%	10.3%	5.1%	59.5%	0.8%	1068
Popayán	24.1%	11.7%	5.9%	57.2%	1.1%	2459

Continúa en la siguiente página

ETC/País	A	B	C	D	Omisión y multimarca	Nº estudiantes
Putumayo	24.4%	11.7%	7.1%	55.5%	1.4%	2703
Quibdó	32.0%	14.5%	11.7%	38.3%	3.5%	1087
Quindío	27.4%	12.6%	7.4%	52.0%	0.6%	2038
Riohacha	29.8%	15.1%	8.8%	44.9%	1.4%	1341
Rionegro	23.1%	9.7%	8.5%	58.0%	0.7%	1086
Risaralda	25.9%	12.4%	7.2%	54.2%	0.3%	1936
Sabaneta	20.4%	10.7%	6.9%	61.1%	1.0%	496
Sahagún	27.2%	13.9%	7.2%	50.9%	0.7%	1079
San Andrés	30.1%	14.7%	8.3%	45.9%	0.9%	529
Santa Marta	29.6%	13.9%	8.9%	46.5%	1.2%	4355
Santander	23.8%	10.4%	6.7%	58.7%	0.4%	6430
Sincedejo	29.8%	14.8%	8.1%	46.2%	1.0%	2695
Soacha	26.3%	11.7%	6.5%	54.4%	1.1%	4802
Sogamoso	23.0%	8.1%	5.1%	63.5%	0.3%	1267
Soledad	29.0%	12.7%	8.4%	48.5%	1.3%	4099
Sucre	30.6%	14.4%	9.9%	44.4%	0.8%	5462
Tolima	27.2%	12.6%	8.0%	51.5%	0.8%	6959
Tuluá	26.7%	10.6%	7.0%	54.9%	0.8%	1832
Tumaco	30.4%	14.6%	11.9%	41.7%	1.4%	1334
Tunja	21.1%	9.5%	5.9%	63.4%	0.0%	1740
Turbo	31.3%	15.9%	9.5%	42.2%	1.1%	1254
Uribe	24.1%	16.6%	9.8%	48.5%	1.0%	307
Valle del Cauca	27.1%	11.2%	7.9%	53.0%	0.8%	6250
Valledupar	27.6%	13.6%	8.5%	49.1%	1.2%	4092
Vichada	29.0%	9.9%	6.9%	53.7%	0.5%	404
Villavicencio	22.9%	10.2%	6.9%	59.3%	0.7%	4110
Yopal	21.6%	9.4%	5.4%	63.4%	0.1%	1395
Yumbo	26.1%	10.7%	6.6%	55.6%	1.0%	894
Zipaquirá	21.5%	9.0%	6.2%	62.9%	0.4%	1155
Colombia	26.0%	12.0%	7.5%	53.6%	1.0%	381883

*Es posible que los porcentajes mostrados no sumen exactamente 100 debido a aproximaciones decimales.

• **Pregunta 6.**

* En el plano cartesiano que se presenta a continuación se construyó una figura.

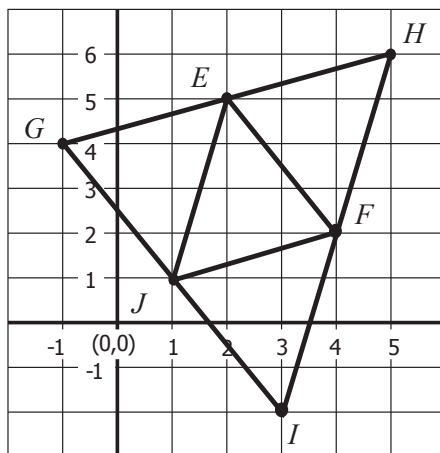

Figura

¿Cuál de los triángulos que aparecen en la figura tiene vértices en los puntos (1,1), (4,2) y (3,-2)?

- A. Triángulo *JGE*.
- B. Triángulo *JGH*.
- C. Triángulo *JFE*.
- D. Triángulo *JFI*.

• **Estructura**

Competencia	Comunicación
Componente	Espacial - métrico
Afirmación	Usar sistemas de referencia para localizar o describir posición de objetos figuras.
Nivel de desempeño	Satisfactorio
Respuesta Correcta	D

• Resultados a nivel nacional y de Entidad Territorial Certificada (ETC)

ETC/País	A	B	C	D	Omisión y multimarca	N° estudiantes
Amazonas	13.6%	16.9%	27.9%	38.8%	2.9%	627
Antioquia	13.6%	12.8%	27.9%	44.1%	1.6%	19243
Apartadó	16.8%	15.9%	30.5%	36.0%	0.7%	1088
Arauca	10.6%	8.9%	26.4%	53.5%	0.6%	1581
Armenia	10.2%	11.9%	24.2%	53.0%	0.7%	2587
Atlántico	15.3%	14.6%	30.3%	38.5%	1.3%	4931
Barrancabermeja	12.6%	11.5%	26.4%	48.3%	1.2%	1845
Barranquilla	13.1%	11.6%	23.7%	50.6%	1.1%	10591
Bello	13.4%	12.1%	25.1%	48.0%	1.4%	3032
Bogotá, D.C.	9.0%	7.7%	19.7%	62.9%	0.7%	62070
Bolívar	15.7%	15.7%	34.2%	32.7%	1.7%	7542
Boyacá	10.5%	7.8%	22.5%	58.8%	0.4%	7836
Bucaramanga	8.4%	7.2%	17.1%	66.3%	0.9%	4498
Buenaventura	15.8%	13.8%	34.4%	34.3%	1.7%	2785
Buga	12.8%	10.9%	21.7%	54.1%	0.5%	917
Caldas	13.3%	12.6%	27.7%	46.0%	0.5%	4430
Cali	11.9%	11.2%	22.9%	53.0%	1.0%	16580
Caquetá	11.9%	12.9%	33.7%	41.1%	0.5%	1658
Cartagena	14.6%	14.4%	27.9%	41.8%	1.3%	9657
Cartago	10.4%	10.1%	23.8%	55.1%	0.6%	1017
Casanare	11.0%	9.9%	23.9%	54.7%	0.5%	2177
Cauca	12.5%	12.4%	29.4%	44.4%	1.3%	8223
Cesar	14.2%	13.7%	30.3%	41.4%	0.4%	5409
Chocó	14.3%	15.7%	36.6%	32.2%	1.2%	2050
Chía	6.6%	4.3%	15.7%	72.9%	0.4%	1416
Ciénaga	17.8%	15.7%	35.5%	29.7%	1.4%	1059
Cundinamarca	9.9%	8.0%	21.2%	60.3%	0.6%	13371
Córdoba	15.5%	15.0%	32.2%	36.1%	1.2%	8943
Cúcuta	11.1%	8.7%	23.2%	56.3%	0.8%	5733
Dosquebradas	12.9%	7.9%	18.7%	60.1%	0.5%	1319
Duitama	7.3%	4.8%	17.6%	70.3%	0.1%	1251
Envigado	7.2%	8.5%	16.5%	67.2%	0.6%	1633
Facatativá	8.7%	6.9%	19.5%	64.4%	0.5%	1114
Florencia	12.2%	11.3%	22.9%	53.0%	0.6%	1382
Floridablanca	8.1%	6.9%	15.4%	68.6%	1.0%	1982
Fusagasugá	11.0%	8.0%	17.8%	62.6%	0.6%	1121
Girardot	12.4%	11.5%	28.7%	46.6%	0.8%	912

Continúa en la siguiente página



ETC/País	A	B	C	D	Omisión y multimarca	N° estudiantes
Girón	12.3%	10.2%	21.6%	55.7%	0.3%	1109
Guainía	7.1%	9.3%	29.0%	54.1%	0.5%	183
Guaviare	13.0%	12.4%	25.9%	47.8%	0.8%	621
Huila	12.3%	8.9%	24.7%	53.6%	0.6%	5194
Ibagué	10.8%	9.7%	21.0%	57.9%	0.6%	4714
Ipiales	9.4%	8.1%	18.0%	64.3%	0.3%	1066
Itagüí	12.8%	13.2%	23.5%	49.1%	1.3%	1746
Jamundí	12.9%	11.2%	26.5%	48.8%	0.6%	939
La Guajira	17.3%	16.1%	32.9%	33.1%	0.5%	2204
Lorica	15.7%	16.5%	33.9%	33.0%	1.0%	1329
Magangué	15.2%	14.9%	29.5%	38.8%	1.6%	1065
Magdalena	16.8%	15.2%	34.8%	31.5%	1.7%	5904
Maicao	17.1%	13.8%	29.7%	38.6%	0.8%	1178
Malambo	13.2%	13.2%	27.7%	44.5%	1.3%	786
Manizales	11.1%	9.2%	23.1%	56.0%	0.6%	2770
Medellín	12.5%	12.0%	23.0%	51.0%	1.4%	17124
Meta	11.9%	10.2%	25.1%	52.0%	0.8%	3789
Montería	14.9%	12.8%	26.7%	44.4%	1.2%	4177
Mosquera	8.8%	7.6%	18.5%	64.4%	0.7%	1158
Nariño	10.3%	9.2%	23.9%	55.7%	0.9%	6043
Neiva	11.3%	7.5%	21.1%	59.4%	0.7%	2951
Norte de Santander	11.2%	9.9%	23.2%	55.1%	0.6%	5090
Palmira	9.1%	7.9%	20.8%	61.4%	0.7%	2330
Pasto	9.6%	7.5%	18.7%	63.5%	0.8%	3211
Pereira	10.8%	9.0%	21.7%	58.1%	0.5%	3748
Piedecuesta	8.1%	9.9%	20.0%	61.0%	1.0%	1186
Pitalito	9.6%	7.2%	21.8%	60.3%	1.0%	1068
Popayán	9.8%	8.7%	21.4%	59.1%	1.0%	2459
Putumayo	11.6%	8.9%	24.9%	53.5%	1.1%	2703
Quibdó	15.4%	15.8%	35.5%	29.8%	3.5%	1087
Quindío	12.4%	12.9%	27.2%	46.9%	0.7%	2038
Riohacha	14.7%	13.7%	26.1%	44.4%	1.0%	1341
Rionegro	12.6%	8.1%	20.3%	58.1%	0.8%	1086
Risaralda	13.3%	9.1%	29.8%	47.6%	0.3%	1936
Sabaneta	9.1%	7.1%	17.9%	65.1%	0.8%	496
Sahagún	14.1%	12.3%	31.9%	41.1%	0.6%	1079
San Andrés	16.1%	16.4%	28.0%	38.9%	0.6%	529
Santa Marta	14.1%	15.6%	28.3%	40.7%	1.3%	4355
Santander	9.4%	8.5%	21.5%	60.1%	0.4%	6430

Continúa en la siguiente página

ETC/País	A	B	C	D	Omisión y multimarca	N° estudiantes
Sincelejo	14.0%	13.8%	27.4%	44.2%	0.6%	2695
Soacha	11.5%	10.8%	24.1%	52.5%	1.0%	4802
Sogamoso	7.6%	6.8%	16.4%	68.8%	0.4%	1267
Soledad	14.3%	13.5%	23.9%	47.0%	1.2%	4099
Sucre	14.9%	14.4%	32.4%	37.6%	0.8%	5462
Tolima	12.6%	11.4%	29.2%	46.0%	0.7%	6959
Tuluá	11.7%	11.2%	24.1%	52.2%	0.9%	1832
Tumaco	15.4%	16.4%	36.2%	29.9%	2.0%	1334
Tunja	6.2%	6.6%	14.9%	72.2%	0.1%	1740
Turbo	18.4%	15.6%	35.5%	29.1%	1.4%	1254
Uribe	13.7%	11.7%	31.6%	42.3%	0.7%	307
Valle del Cauca	12.0%	11.8%	28.2%	47.2%	0.9%	6250
Valledupar	15.2%	12.6%	25.8%	45.6%	0.8%	4092
Vichada	14.1%	12.9%	32.4%	39.4%	1.2%	404
Villavicencio	9.8%	9.3%	19.4%	60.9%	0.7%	4110
Yopal	9.4%	8.9%	19.2%	62.4%	0.1%	1395
Yumbo	12.4%	10.7%	22.9%	53.2%	0.7%	894
Zipaquirá	7.2%	6.1%	15.0%	71.2%	0.6%	1155
Colombia	11.9%	10.8%	24.6%	51.8%	0.9%	381883

*Es posible que los porcentajes mostrados no sumen exactamente 100 debido a aproximaciones decimales.

• **Pregunta 7.**

En la gráfica se representa el cambio del voltaje de dos tipos de baterías (I y II) en función del tiempo, cuando estas se usan continuamente.

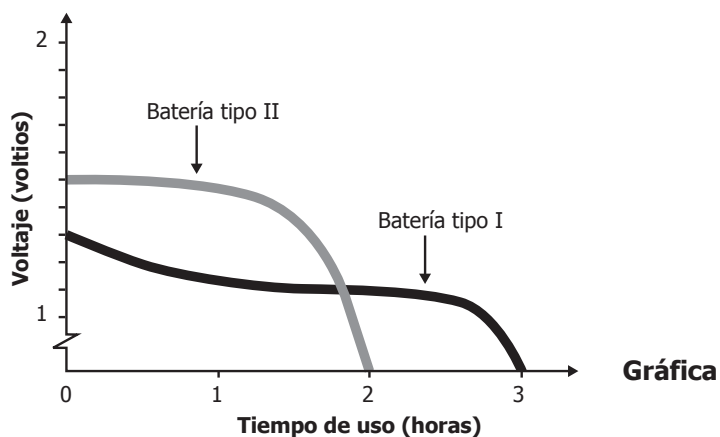

¿Cuáles son los voltajes iniciales (en voltios) de las baterías tipo I y tipo II?

- A. 0,5 y 0,7 respectivamente.
- B. 1,3 y 1,5 respectivamente.
- C. 2 y 3 respectivamente.
- D. 4 y 6 respectivamente.

• **Estructura**

Competencia	Comunicación
Componente	Numérico - variacional
Afirmación	Identificar características de las graficas cartesianas en relación con la situación que representa.
Nivel de desempeño	Avanzado
Respuesta Correcta	B

• Resultados a nivel nacional y de Entidad Territorial Certificada (ETC)

ETC/País	A	B	C	D	Omisión y multimarca	N° estudiantes
Amazonas	6.5%	30.1%	33.0%	27.3%	3.0%	627
Antioquia	9.0%	35.1%	23.5%	30.6%	1.8%	19243
Apartadó	11.8%	32.7%	22.3%	32.1%	1.1%	1088
Arauca	7.3%	38.1%	21.1%	33.1%	0.4%	1581
Armenia	9.0%	42.8%	18.6%	28.8%	0.8%	2587
Atlántico	10.1%	30.0%	26.1%	31.9%	1.9%	4931
Barrancabermeja	8.5%	37.6%	19.5%	33.3%	1.1%	1845
Barranquilla	8.8%	38.0%	20.2%	31.9%	1.1%	10591
Bello	9.5%	37.9%	19.1%	32.0%	1.6%	3032
Bogotá, D.C.	6.8%	45.9%	15.5%	30.9%	0.8%	62070
Bolívar	10.8%	29.0%	28.9%	29.4%	1.9%	7542
Boyacá	7.6%	43.2%	17.3%	31.5%	0.5%	7836
Bucaramanga	7.0%	45.4%	14.3%	32.5%	0.8%	4498
Buenaventura	10.2%	30.3%	28.2%	29.5%	1.8%	2785
Buga	7.2%	38.8%	18.5%	34.1%	1.3%	917
Caldas	9.1%	34.6%	23.7%	32.1%	0.6%	4430
Cali	8.5%	39.8%	19.2%	31.4%	1.1%	16580
Caquetá	8.7%	36.0%	24.1%	30.3%	0.9%	1658
Cartagena	10.3%	34.5%	23.4%	30.3%	1.5%	9657
Cartago	6.9%	36.9%	17.2%	38.0%	1.1%	1017
Casanare	7.3%	40.5%	19.2%	32.4%	0.7%	2177
Cauca	8.5%	33.6%	27.8%	28.5%	1.5%	8223
Cesar	9.5%	33.6%	25.2%	31.2%	0.5%	5409
Chocó	8.7%	28.6%	33.9%	27.2%	1.7%	2050
Chía	5.6%	52.9%	12.8%	28.3%	0.4%	1416
Ciénaga	11.8%	28.7%	30.7%	27.1%	1.7%	1059
Cundinamarca	7.2%	44.2%	17.0%	31.0%	0.6%	13371
Córdoba	9.5%	30.2%	27.8%	31.0%	1.5%	8943
Cúcuta	7.2%	42.2%	17.7%	32.0%	0.9%	5733
Dosquebradas	6.6%	41.6%	16.1%	35.0%	0.7%	1319
Duitama	6.5%	50.0%	12.4%	30.9%	0.2%	1251
Envigado	7.0%	52.3%	12.7%	27.3%	0.7%	1633
Facatativá	7.0%	46.1%	14.6%	31.5%	0.8%	1114
Florencia	6.6%	42.6%	18.2%	31.7%	0.9%	1382
Floridablanca	5.8%	47.5%	12.6%	33.2%	0.9%	1982
Fusagasugá	7.4%	46.8%	15.2%	30.1%	0.5%	1121
Girardot	8.6%	35.9%	22.3%	32.8%	0.5%	912

Continúa en la siguiente página



ETC/País	A	B	C	D	Omisión y multimarca	N° estudiantes
Girón	8.4%	39.6%	17.9%	33.9%	0.3%	1109
Guainía	6.6%	42.1%	25.7%	24.6%	1.1%	183
Guaviare	7.6%	36.4%	25.6%	29.1%	1.3%	621
Huila	8.1%	38.3%	21.2%	31.7%	0.7%	5194
Ibagué	7.2%	42.5%	17.4%	32.1%	0.7%	4714
Ipiales	6.7%	46.9%	15.9%	30.3%	0.3%	1066
Itagüí	9.1%	38.9%	18.7%	31.6%	1.8%	1746
Jamundí	7.5%	37.7%	22.4%	32.2%	0.3%	939
La Guajira	10.2%	31.3%	28.4%	29.3%	0.8%	2204
Lorica	10.2%	29.0%	30.1%	29.6%	1.1%	1329
Magangué	8.5%	31.2%	25.9%	33.1%	1.3%	1065
Magdalena	9.7%	28.4%	29.7%	30.3%	1.8%	5904
Maicao	11.5%	30.1%	27.5%	29.8%	1.1%	1178
Malambo	10.9%	36.0%	24.2%	28.4%	0.5%	786
Manizales	8.3%	39.7%	18.6%	32.8%	0.7%	2770
Medellín	8.9%	39.3%	18.8%	31.3%	1.7%	17124
Meta	8.3%	39.9%	21.2%	29.6%	1.0%	3789
Montería	8.4%	35.1%	22.1%	33.1%	1.3%	4177
Mosquera	7.3%	49.5%	13.0%	29.4%	0.8%	1158
Nariño	7.9%	40.0%	20.3%	30.6%	1.2%	6043
Neiva	6.8%	43.6%	15.8%	32.8%	1.0%	2951
Norte de Santander	8.0%	39.8%	20.1%	31.5%	0.7%	5090
Palmira	5.3%	46.7%	16.1%	30.6%	1.3%	2330
Pasto	6.8%	44.4%	16.3%	31.7%	0.8%	3211
Pereira	7.1%	42.4%	17.5%	32.5%	0.6%	3748
Piedecuesta	7.5%	43.0%	16.6%	31.6%	1.3%	1186
Pitalito	7.4%	46.1%	15.4%	30.4%	0.7%	1068
Popayán	7.3%	43.8%	17.5%	30.3%	1.1%	2459
Putumayo	6.4%	40.8%	20.9%	30.9%	1.0%	2703
Quibdó	9.1%	28.2%	29.2%	29.9%	3.6%	1087
Quindío	9.6%	36.6%	22.5%	30.7%	0.6%	2038
Riohacha	9.5%	31.8%	24.1%	32.7%	1.9%	1341
Rionegro	6.6%	47.1%	18.3%	27.1%	0.9%	1086
Risaralda	7.5%	38.2%	23.8%	29.9%	0.6%	1936
Sabaneta	7.9%	48.8%	13.9%	28.6%	0.8%	496
Sahagún	9.5%	31.9%	24.3%	33.5%	0.7%	1079
San Andrés	11.0%	29.7%	26.5%	32.1%	0.8%	529
Santa Marta	8.9%	35.0%	23.9%	30.6%	1.6%	4355
Santander	6.6%	43.4%	17.4%	32.1%	0.5%	6430

Continúa en la siguiente página

ETC/País	A	B	C	D	Omisión y multimarca	N° estudiantes
Sincelejo	9.9%	35.3%	23.4%	30.3%	1.1%	2695
Soacha	7.7%	41.6%	19.0%	30.5%	1.2%	4802
Sogamoso	5.4%	48.5%	14.8%	30.9%	0.3%	1267
Soledad	9.4%	37.1%	21.2%	30.7%	1.6%	4099
Sucre	9.5%	30.0%	28.3%	31.3%	1.0%	5462
Tolima	8.3%	35.9%	24.4%	30.4%	1.0%	6959
Tuluá	7.8%	38.4%	19.6%	33.2%	1.0%	1832
Tumaco	10.0%	26.8%	34.2%	26.9%	2.2%	1334
Tunja	6.7%	48.5%	13.3%	31.3%	0.2%	1740
Turbo	10.7%	24.9%	32.0%	31.1%	1.4%	1254
Uribe	6.8%	30.3%	33.6%	28.3%	1.0%	307
Valle del Cauca	8.1%	36.9%	23.2%	30.7%	1.0%	6250
Valledupar	9.7%	34.9%	21.8%	32.8%	0.8%	4092
Vichada	9.4%	31.4%	27.5%	30.4%	1.2%	404
Villavicencio	7.6%	42.1%	17.8%	31.6%	0.9%	4110
Yopal	6.0%	46.6%	15.2%	32.0%	0.2%	1395
Yumbo	6.6%	37.9%	20.8%	34.1%	0.6%	894
Zipaquirá	6.0%	47.3%	13.9%	32.3%	0.5%	1155
Colombia	8.2%	39.3%	20.4%	31.1%	1.1%	381883

*Es posible que los porcentajes mostrados no sumen exactamente 100 debido a aproximaciones decimales.

• **Pregunta 8.**

Las figuras 1 y 2 están dibujadas sobre una cuadrícula. La figura 2 se obtuvo aplicando una secuencia de transformaciones a la figura 1, que incluye únicamente ampliaciones, reflexiones con respecto a los ejes horizontal y vertical, reducciones y rotaciones.



Figura 1



Figura 2

¿Cuál es la secuencia de transformaciones?

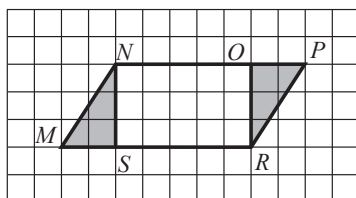
- A. Ampliación, reflexión, reflexión.
- B. Rotación, reflexión, reducción.
- C. Rotación, reflexión, ampliación.
- D. Ampliación, rotación, reducción.

• **Estructura**

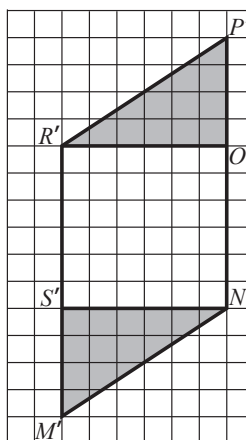
Competencia	Razonamiento
Componente	Espacial - métrico
Afirmación	Hacer conjeturas y verificar propiedades de congruencias y semejanza entre figuras bidimensionales.
Nivel de desempeño	Satisfactorio
Respuesta Correcta	C

• Resultados a nivel nacional y de Entidad Territorial Certificada (ETC)

ETC/País	A	B	C	D	Omisión y multimarca	N° estudiantes
Amazonas	11.3%	14.5%	46.7%	24.2%	3.2%	627
Antioquia	9.5%	15.0%	50.8%	23.0%	1.8%	19243
Apartadó	12.9%	16.5%	44.6%	25.1%	0.9%	1088
Arauca	7.8%	13.4%	57.0%	21.2%	0.6%	1581
Armenia	10.2%	13.1%	57.9%	17.8%	1.0%	2587
Atlántico	12.2%	17.4%	44.3%	24.3%	1.8%	4931
Barrancabermeja	10.8%	14.5%	54.7%	18.8%	1.2%	1845
Barranquilla	10.2%	14.1%	53.9%	20.3%	1.4%	10591
Bello	9.3%	13.6%	55.9%	19.4%	1.8%	3032
Bogotá, D.C.	7.3%	11.4%	63.5%	16.9%	0.9%	62070
Bolívar	11.9%	18.8%	40.0%	27.4%	1.9%	7542
Boyacá	7.7%	12.5%	59.8%	19.4%	0.6%	7836
Bucaramanga	6.7%	10.4%	66.9%	14.9%	1.2%	4498
Buenaventura	12.3%	17.2%	40.9%	27.5%	2.1%	2785
Buga	8.2%	13.3%	56.8%	20.7%	1.0%	917
Caldas	9.5%	13.7%	53.8%	22.4%	0.6%	4430
Cali	9.2%	13.2%	56.7%	19.5%	1.4%	16580
Caquetá	9.8%	15.4%	49.2%	24.8%	0.8%	1658
Cartagena	11.4%	16.5%	48.2%	22.3%	1.7%	9657
Cartago	6.5%	12.5%	60.8%	19.1%	1.2%	1017
Casanare	8.5%	13.4%	54.9%	22.4%	0.7%	2177
Cauca	9.6%	16.5%	46.5%	25.7%	1.6%	8223
Cesar	11.7%	16.5%	46.7%	24.6%	0.5%	5409
Chocó	11.6%	17.0%	40.0%	29.8%	1.6%	2050
Chía	6.5%	9.5%	70.2%	13.4%	0.4%	1416
Ciénaga	13.0%	19.0%	41.6%	24.6%	1.7%	1059
Cundinamarca	7.5%	12.2%	60.8%	18.9%	0.7%	13371
Córdoba	11.1%	17.4%	42.7%	27.4%	1.4%	8943
Cúcuta	8.3%	12.4%	57.6%	20.7%	1.0%	5733
Dosquebradas	7.2%	10.2%	63.5%	18.3%	0.8%	1319
Duitama	7.0%	9.5%	71.8%	11.4%	0.2%	1251
Envigado	7.6%	11.1%	67.0%	13.5%	0.9%	1633
Facatativá	5.9%	8.9%	68.3%	16.1%	0.8%	1114
Florencia	7.7%	13.2%	54.3%	23.6%	1.2%	1382
Floridablanca	7.7%	11.3%	65.6%	14.6%	0.8%	1982
Fusagasugá	6.7%	11.3%	64.9%	16.3%	0.8%	1121
Girardot	9.4%	14.8%	50.8%	23.9%	1.1%	912

Continúa en la siguiente página



ETC/País	A	B	C	D	Omisión y multimarca	N° estudiantes
Girón	8.7%	13.1%	59.0%	18.9%	0.3%	1109
Guainía	8.2%	12.6%	59.6%	19.1%	0.5%	183
Guaviare	9.2%	16.7%	51.2%	22.1%	0.8%	621
Huila	9.0%	13.3%	54.0%	23.2%	0.6%	5194
Ibagué	8.7%	13.2%	59.5%	17.8%	0.8%	4714
Ipiales	8.6%	14.6%	59.7%	16.6%	0.5%	1066
Itagüí	11.9%	14.1%	52.2%	20.2%	1.6%	1746
Jamundí	8.4%	16.0%	51.5%	23.4%	0.6%	939
La Guajira	11.3%	18.0%	42.1%	27.6%	0.9%	2204
Lorica	12.5%	18.9%	40.7%	27.0%	0.9%	1329
Magangué	10.6%	16.1%	47.9%	23.8%	1.6%	1065
Magdalena	13.2%	18.8%	38.1%	28.3%	1.7%	5904
Maicao	10.8%	17.1%	43.9%	26.8%	1.4%	1178
Malambo	11.6%	13.6%	48.2%	25.7%	0.9%	786
Manizales	8.4%	12.3%	60.8%	17.7%	0.8%	2770
Medellín	9.2%	13.9%	56.1%	19.1%	1.7%	17124
Meta	8.8%	15.1%	55.1%	20.3%	0.7%	3789
Montería	10.3%	15.4%	47.7%	25.3%	1.2%	4177
Mosquera	6.7%	10.9%	65.7%	16.1%	0.6%	1158
Nariño	8.6%	13.4%	56.7%	20.2%	1.1%	6043
Neiva	7.9%	12.8%	59.2%	19.2%	0.9%	2951
Norte de Santander	8.5%	14.1%	55.7%	20.8%	0.9%	5090
Palmira	7.8%	11.3%	62.6%	17.1%	1.2%	2330
Pasto	7.2%	11.3%	65.2%	15.4%	1.0%	3211
Pereira	8.8%	12.2%	60.0%	18.4%	0.6%	3748
Piedecuesta	8.0%	11.9%	61.6%	17.0%	1.5%	1186
Pitalito	8.2%	12.8%	59.4%	18.4%	1.2%	1068
Popayán	8.5%	12.8%	60.8%	16.6%	1.4%	2459
Putumayo	8.8%	13.7%	52.5%	23.6%	1.3%	2703
Quibdó	11.2%	19.2%	36.9%	28.8%	3.9%	1087
Quindío	10.5%	15.5%	52.3%	21.1%	0.6%	2038
Riohacha	11.2%	14.5%	49.1%	23.8%	1.5%	1341
Rionegro	7.3%	11.4%	60.5%	20.1%	0.7%	1086
Risaralda	8.0%	13.9%	54.3%	22.9%	0.8%	1936
Sabaneta	7.3%	8.9%	67.3%	15.5%	1.0%	496
Sahagún	8.7%	14.2%	49.7%	25.9%	1.6%	1079
San Andrés	11.7%	18.5%	45.6%	23.3%	0.9%	529
Santa Marta	10.8%	17.3%	49.4%	20.9%	1.5%	4355
Santander	8.3%	12.2%	60.5%	18.5%	0.6%	6430

Continúa en la siguiente página

ETC/País	A	B	C	D	Omisión y multimarca	Nº estudiantes
Sincelejo	11.5%	14.2%	49.3%	23.8%	1.2%	2695
Soacha	8.6%	12.6%	58.1%	19.4%	1.3%	4802
Sogamoso	6.6%	11.8%	67.2%	13.8%	0.6%	1267
Soledad	10.5%	14.3%	53.2%	20.6%	1.4%	4099
Sucre	11.1%	17.9%	44.6%	25.5%	1.0%	5462
Tolima	9.3%	14.5%	51.1%	24.1%	1.0%	6959
Tuluá	8.4%	12.2%	57.5%	21.1%	0.8%	1832
Tumaco	11.3%	19.3%	38.0%	29.5%	1.9%	1334
Tunja	5.8%	9.9%	69.5%	14.5%	0.2%	1740
Turbo	12.0%	17.7%	36.6%	31.9%	1.8%	1254
Uribe	9.4%	21.2%	34.2%	32.9%	2.3%	307
Valle del Cauca	9.4%	14.1%	53.5%	22.0%	1.0%	6250
Valledupar	10.8%	14.9%	50.6%	22.6%	1.0%	4092
Vichada	9.7%	18.1%	45.8%	25.5%	1.0%	404
Villavicencio	7.8%	13.1%	60.2%	17.9%	0.9%	4110
Yopal	6.1%	10.7%	65.7%	17.4%	0.1%	1395
Yumbo	8.9%	15.3%	54.0%	20.0%	1.7%	894
Zipaquirá	6.2%	9.7%	69.0%	14.4%	0.7%	1155
Colombia	9.1%	13.8%	55.2%	20.7%	1.1%	381883

*Es posible que los porcentajes mostrados no sumen exactamente 100 debido a aproximaciones decimales.

• **Pregunta 9.**

La balanza de la figura está en equilibrio.

La ecuación $2(x + y) = 2z$, donde x corresponde a la masa de cada plato, y a la masa de cada pocillo y z a la masa de cada botella, representa la situación.

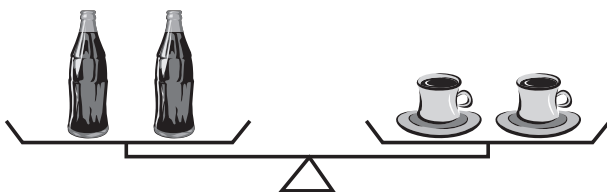

Figura

¿Cuáles de las siguientes son posibles masas, en gramos, de los objetos?

- A. $x = 20, y = 15$ y $z = 35$
- B. $x = 40, y = 10$ y $z = 30$
- C. $x = 35, y = 15$ y $z = 20$
- D. $x = 30, y = 40$ y $z = 10$

• **Estructura**

Competencia	Razonamiento
Componente	Numérico - variacional
Afirmación	Utilizar propiedades y relaciones de los números reales para resolver problemas.
Nivel de desempeño	Satisfactorio
Respuesta Correcta	A

• Resultados a nivel nacional y de Entidad Territorial Certificada (ETC)

ETC/País	A	B	C	D	Omisión y multimarca	N° estudiantes
Amazonas	39.7%	25.2%	16.9%	14.8%	3.3%	627
Antioquia	43.8%	25.3%	17.8%	11.0%	2.1%	19243
Apartadó	42.0%	27.9%	18.5%	10.6%	1.0%	1088
Arauca	47.1%	25.5%	17.6%	9.2%	0.6%	1581
Armenia	46.6%	24.9%	17.9%	9.5%	1.1%	2587
Atlántico	45.1%	25.2%	16.7%	11.3%	1.6%	4931
Barrancabermeja	46.6%	24.0%	16.5%	11.3%	1.6%	1845
Barranquilla	50.1%	23.2%	15.5%	9.8%	1.5%	10591
Bello	47.9%	23.3%	17.9%	9.3%	1.6%	3032
Bogotá, D.C.	52.7%	22.0%	15.9%	8.3%	1.2%	62070
Bolívar	42.8%	26.2%	17.4%	11.7%	1.8%	7542
Boyacá	49.0%	23.4%	16.8%	10.2%	0.6%	7836
Bucaramanga	55.2%	20.0%	15.5%	7.8%	1.5%	4498
Buenaventura	43.6%	25.5%	17.6%	11.2%	2.1%	2785
Buga	48.5%	23.1%	17.4%	9.7%	1.2%	917
Caldas	44.9%	25.3%	17.9%	11.2%	0.8%	4430
Cali	49.1%	23.3%	16.6%	9.3%	1.7%	16580
Caquetá	41.0%	26.7%	19.4%	11.6%	1.2%	1658
Cartagena	49.1%	23.3%	16.1%	10.1%	1.5%	9657
Cartago	48.2%	23.4%	17.5%	9.4%	1.5%	1017
Casanare	47.9%	23.7%	18.1%	9.8%	0.6%	2177
Cauca	42.1%	26.4%	18.0%	11.7%	1.7%	8223
Cesar	45.1%	25.3%	18.0%	10.8%	0.8%	5409
Chocó	42.8%	25.1%	17.3%	13.2%	1.6%	2050
Chía	59.0%	18.6%	13.7%	7.3%	1.3%	1416
Ciénaga	42.3%	25.7%	17.8%	12.3%	2.0%	1059
Cundinamarca	50.5%	22.6%	16.7%	9.3%	0.9%	13371
Córdoba	41.5%	26.1%	18.7%	12.4%	1.3%	8943
Cúcuta	53.1%	21.6%	15.6%	8.5%	1.2%	5733
Dosquebradas	50.0%	22.0%	16.5%	10.2%	1.2%	1319
Duitama	60.0%	18.0%	15.2%	6.4%	0.4%	1251
Envigado	58.1%	19.4%	14.3%	7.3%	0.9%	1633
Facatativá	55.1%	20.3%	14.8%	8.9%	0.9%	1114
Florencia	46.5%	24.7%	16.9%	10.4%	1.4%	1382
Floridablanca	58.0%	18.1%	15.3%	7.5%	1.2%	1982
Fusagasugá	53.6%	20.1%	17.1%	8.1%	1.1%	1121
Girardot	49.0%	22.6%	16.8%	10.6%	1.0%	912

Continúa en la siguiente página



ETC/País	A	B	C	D	Omisión y multimarca	N° estudiantes
Girón	51.9%	20.6%	17.6%	9.2%	0.7%	1109
Guainía	36.6%	28.4%	23.0%	10.9%	1.1%	183
Guaviare	44.8%	23.2%	18.0%	12.7%	1.3%	621
Huila	47.0%	24.7%	17.6%	9.9%	0.8%	5194
Ibagué	49.7%	23.7%	16.7%	8.9%	0.9%	4714
Ipiales	48.6%	22.8%	18.4%	9.5%	0.8%	1066
Itagüí	47.9%	24.2%	16.4%	9.5%	2.0%	1746
Jamundí	46.5%	22.0%	17.4%	13.0%	1.1%	939
La Guajira	43.5%	25.1%	18.2%	12.3%	0.9%	2204
Lorica	42.9%	27.6%	16.7%	11.7%	1.1%	1329
Magangué	45.6%	23.8%	16.7%	12.1%	1.7%	1065
Magdalena	42.9%	25.7%	18.4%	11.1%	1.9%	5904
Maicao	45.8%	26.5%	15.6%	11.2%	0.8%	1178
Malambo	54.6%	20.0%	14.5%	9.5%	1.4%	786
Manizales	48.2%	23.4%	18.2%	9.7%	0.5%	2770
Medellín	47.6%	23.3%	17.1%	10.2%	1.8%	17124
Meta	44.9%	25.4%	19.0%	9.7%	1.0%	3789
Montería	49.3%	22.8%	17.4%	9.3%	1.2%	4177
Mosquera	52.8%	22.5%	15.8%	7.6%	1.3%	1158
Nariño	47.5%	23.4%	17.0%	10.8%	1.2%	6043
Neiva	51.6%	22.7%	14.9%	9.4%	1.3%	2951
Norte de Santander	48.9%	23.5%	16.4%	10.4%	0.8%	5090
Palmira	51.7%	20.8%	16.7%	8.9%	1.9%	2330
Pasto	50.5%	22.0%	15.7%	10.3%	1.5%	3211
Pereira	50.6%	22.4%	17.4%	8.8%	0.7%	3748
Piedecuesta	53.5%	21.0%	15.1%	9.1%	1.3%	1186
Pitalito	50.4%	21.9%	17.8%	9.1%	0.8%	1068
Popayán	48.9%	23.0%	16.4%	9.6%	2.1%	2459
Putumayo	46.9%	22.8%	18.2%	10.4%	1.7%	2703
Quibdó	40.0%	24.4%	18.9%	12.6%	4.1%	1087
Quindío	45.1%	23.8%	18.2%	12.1%	0.8%	2038
Riohacha	45.6%	25.1%	16.1%	12.0%	1.2%	1341
Rionegro	52.7%	23.0%	16.3%	7.3%	0.7%	1086
Risaralda	45.8%	23.6%	19.3%	10.7%	0.6%	1936
Sabaneta	52.8%	22.0%	15.7%	8.3%	1.2%	496
Sahagún	44.7%	23.2%	19.2%	12.0%	1.0%	1079
San Andrés	46.9%	26.3%	16.8%	9.3%	0.8%	529
Santa Marta	46.2%	22.8%	17.6%	11.5%	1.8%	4355
Santander	50.4%	23.0%	16.6%	9.2%	0.7%	6430

Continúa en la siguiente página

ETC/País	A	B	C	D	Omisión y multimarca	N° estudiantes
Sincelejo	48.8%	23.3%	16.7%	10.2%	0.9%	2695
Soacha	47.4%	24.8%	16.8%	9.6%	1.4%	4802
Sogamoso	57.1%	21.0%	12.7%	8.6%	0.6%	1267
Soledad	48.5%	22.5%	16.2%	11.4%	1.3%	4099
Sucre	42.7%	25.2%	18.9%	12.0%	1.1%	5462
Tolima	43.9%	25.2%	18.9%	10.9%	1.1%	6959
Tuluá	47.1%	22.7%	18.4%	10.5%	1.3%	1832
Tumaco	41.2%	24.6%	19.9%	12.3%	2.0%	1334
Tunja	60.2%	18.5%	13.8%	7.4%	0.1%	1740
Turbo	39.6%	29.5%	17.1%	12.4%	1.4%	1254
Uribe	39.4%	24.4%	20.8%	13.7%	1.6%	307
Valle del Cauca	45.7%	24.3%	17.2%	11.5%	1.2%	6250
Valledupar	48.1%	24.5%	15.7%	10.4%	1.2%	4092
Vichada	41.8%	25.2%	18.6%	12.6%	1.7%	404
Villavicencio	50.4%	22.9%	16.5%	9.3%	0.9%	4110
Yopal	53.5%	19.8%	17.6%	8.6%	0.6%	1395
Yumbo	46.1%	26.6%	16.2%	9.6%	1.5%	894
Zipaquirá	55.8%	20.1%	15.6%	7.6%	0.9%	1155
Colombia	48.4%	23.5%	16.9%	9.9%	1.3%	381883

*Es posible que los porcentajes mostrados no sumen exactamente 100 debido a aproximaciones decimales.

• **Pregunta 10.**

La gráfica representa el número de hombres y de mujeres de una región del país que compraron moto en un concesionario, durante el segundo semestre del año pasado.

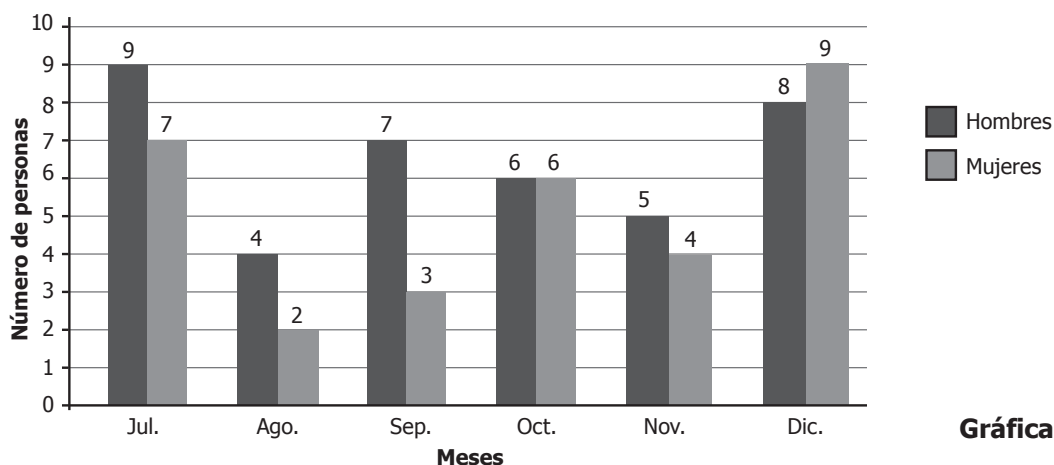

Se va a premiar un comprador, elegido al azar, con un bono de \$500.000 en mantenimiento de la moto. De acuerdo con la información de la gráfica es correcto afirmar:

- A. La probabilidad de que el ganador del bono sea una mujer es igual a la probabilidad de que sea un hombre.
- B. Si el ganador del bono es una mujer, es más probable que haya comprado la moto entre julio y septiembre, que entre octubre y diciembre.
- C. La probabilidad de que el ganador del bono sea un hombre es menor que la probabilidad de que sea una mujer.
- D. Si el ganador del bono es un hombre, es igualmente probable que haya comprado la moto entre julio y agosto, que entre noviembre y diciembre.

• **Estructura**

Competencia	Razonamiento
Componente	Aleatorio
Afirmación	Usar modelos para discutir acerca de la probabilidad de un evento aleatorio.
Nivel de desempeño	Avanzado
Respuesta Correcta	D

• Resultados a nivel nacional y de Entidad Territorial Certificada (ETC)

ETC/País	A	B	C	D	Omisión y multimarca	N° estudiantes
Amazonas	25.7%	19.8%	18.5%	32.9%	3.2%	627
Antioquia	30.3%	17.0%	17.4%	33.4%	1.9%	19243
Apartadó	28.5%	20.2%	21.0%	29.3%	1.0%	1088
Arauca	30.0%	13.7%	20.9%	34.9%	0.6%	1581
Armenia	26.6%	15.9%	17.4%	39.4%	0.7%	2587
Atlántico	24.7%	19.7%	18.3%	35.7%	1.6%	4931
Barrancabermeja	23.9%	18.0%	19.0%	37.7%	1.4%	1845
Barranquilla	24.3%	16.1%	18.4%	40.1%	1.0%	10591
Bello	25.9%	16.8%	17.5%	38.6%	1.3%	3032
Bogotá, D.C.	25.4%	13.3%	16.4%	44.0%	0.9%	62070
Bolívar	26.2%	21.1%	20.4%	30.5%	1.8%	7542
Boyacá	29.4%	14.1%	18.6%	37.4%	0.5%	7836
Bucaramanga	23.5%	12.2%	17.2%	46.1%	1.1%	4498
Buenaventura	26.4%	19.4%	18.2%	34.4%	1.6%	2785
Buga	32.4%	12.2%	17.4%	37.1%	0.9%	917
Caldas	31.6%	15.7%	17.7%	34.3%	0.7%	4430
Cali	26.7%	15.2%	18.1%	38.8%	1.3%	16580
Caquetá	30.8%	17.2%	20.3%	30.8%	0.9%	1658
Cartagena	24.0%	19.4%	19.3%	35.8%	1.5%	9657
Cartago	25.7%	14.8%	20.0%	38.4%	1.1%	1017
Casanare	30.9%	15.5%	18.6%	34.4%	0.6%	2177
Cauca	31.2%	19.5%	18.5%	29.2%	1.5%	8223
Cesar	27.4%	18.9%	19.7%	33.4%	0.6%	5409
Chocó	28.0%	20.9%	16.0%	33.2%	1.9%	2050
Chía	22.7%	11.3%	14.4%	50.6%	1.0%	1416
Ciénaga	24.6%	21.0%	19.7%	33.1%	1.6%	1059
Cundinamarca	28.6%	13.9%	18.2%	38.7%	0.7%	13371
Córdoba	27.5%	19.4%	19.6%	32.2%	1.3%	8943
Cúcuta	25.0%	14.3%	19.3%	40.5%	0.9%	5733
Dosquebradas	27.5%	12.9%	17.5%	41.5%	0.6%	1319
Duitama	23.3%	11.8%	14.5%	50.1%	0.2%	1251
Envigado	20.8%	15.1%	14.8%	48.4%	0.9%	1633
Facatativá	29.4%	12.1%	15.4%	42.5%	0.5%	1114
Florencia	32.3%	13.2%	20.2%	33.7%	0.7%	1382
Floridablanca	23.2%	12.9%	15.4%	47.4%	1.1%	1982
Fusagasugá	26.9%	15.6%	18.2%	38.4%	0.8%	1121
Girardot	29.9%	15.7%	18.3%	34.9%	1.2%	912

Continúa en la siguiente página



ETC/País	A	B	C	D	Omisión y multimarca	N° estudiantes
Girón	29.8%	13.6%	17.6%	38.9%	0.2%	1109
Guainía	26.8%	18.6%	15.8%	37.7%	1.1%	183
Guaviare	33.7%	15.8%	16.9%	32.9%	0.8%	621
Huila	29.2%	15.0%	20.7%	34.5%	0.6%	5194
Ibagué	27.0%	14.9%	18.3%	38.8%	1.0%	4714
Ipiales	29.6%	13.7%	19.1%	37.4%	0.1%	1066
Itagüí	28.9%	17.1%	17.8%	34.8%	1.4%	1746
Jamundí	29.5%	16.1%	18.2%	35.1%	1.1%	939
La Guajira	25.5%	19.3%	19.2%	34.9%	1.0%	2204
Lorica	26.0%	21.3%	19.8%	32.2%	0.8%	1329
Magangué	28.5%	16.6%	20.3%	32.8%	1.8%	1065
Magdalena	26.5%	20.6%	19.5%	31.6%	1.9%	5904
Maicao	26.1%	17.5%	20.6%	34.8%	0.9%	1178
Malambo	22.3%	17.4%	19.5%	39.8%	1.0%	786
Manizales	30.5%	14.7%	15.4%	38.7%	0.8%	2770
Medellín	26.8%	16.6%	17.6%	37.4%	1.6%	17124
Meta	27.7%	15.3%	20.0%	36.0%	1.1%	3789
Montería	25.1%	18.7%	18.7%	36.1%	1.4%	4177
Mosquera	27.7%	12.6%	15.5%	43.5%	0.6%	1158
Nariño	28.7%	14.2%	20.3%	35.6%	1.2%	6043
Neiva	24.2%	14.3%	19.6%	40.8%	1.1%	2951
Norte de Santander	28.4%	15.4%	19.6%	35.9%	0.7%	5090
Palmira	24.8%	15.0%	17.6%	41.2%	1.3%	2330
Pasto	28.5%	13.8%	18.7%	38.2%	0.8%	3211
Pereira	27.9%	14.4%	18.0%	39.0%	0.6%	3748
Piedecuesta	28.2%	12.8%	17.4%	40.4%	1.3%	1186
Pitalito	28.9%	12.4%	17.3%	40.5%	0.8%	1068
Popayán	30.4%	14.1%	17.4%	36.6%	1.5%	2459
Putumayo	29.3%	16.6%	20.2%	32.5%	1.3%	2703
Quibdó	21.2%	23.4%	18.7%	33.2%	3.6%	1087
Quindío	29.8%	16.8%	19.4%	33.3%	0.7%	2038
Riohacha	26.3%	17.2%	20.1%	35.2%	1.2%	1341
Rionegro	29.2%	13.9%	16.5%	39.8%	0.6%	1086
Risaralda	30.2%	16.2%	19.4%	33.6%	0.6%	1936
Sabaneta	28.6%	12.1%	11.7%	46.4%	1.2%	496
Sahagún	26.3%	19.2%	19.8%	34.0%	0.6%	1079
San Andrés	26.8%	17.8%	20.2%	34.2%	0.9%	529
Santa Marta	26.2%	17.5%	17.4%	37.3%	1.6%	4355
Santander	28.4%	13.6%	17.7%	39.6%	0.6%	6430

Continúa en la siguiente página

ETC/País	A	B	C	D	Omisión y multimarca	Nº estudiantes
Sincelejo	26.3%	18.2%	18.7%	36.1%	0.7%	2695
Soacha	29.5%	15.4%	18.8%	35.0%	1.2%	4802
Sogamoso	25.7%	12.9%	15.3%	45.5%	0.7%	1267
Soledad	26.1%	16.2%	19.4%	37.1%	1.2%	4099
Sucre	27.8%	19.0%	19.8%	32.4%	1.0%	5462
Tolima	30.0%	16.4%	19.1%	33.5%	0.9%	6959
Tuluá	27.2%	15.8%	18.6%	37.2%	1.3%	1832
Tumaco	29.4%	21.7%	16.7%	30.1%	2.2%	1334
Tunja	23.9%	12.5%	15.2%	48.2%	0.3%	1740
Turbo	31.3%	19.5%	17.9%	30.3%	1.1%	1254
Uribe	25.4%	20.8%	20.8%	30.6%	2.3%	307
Valle del Cauca	29.0%	16.1%	20.0%	33.9%	1.0%	6250
Valledupar	24.7%	16.7%	20.3%	37.4%	0.9%	4092
Vichada	30.0%	19.6%	19.3%	30.0%	1.2%	404
Villavicencio	26.4%	14.2%	17.5%	41.2%	0.7%	4110
Yopal	25.7%	14.0%	18.6%	41.3%	0.5%	1395
Yumbo	28.5%	14.3%	16.1%	40.0%	1.0%	894
Zipaquirá	29.5%	12.8%	15.6%	41.5%	0.6%	1155
Colombia	27.1%	15.9%	18.2%	37.7%	1.1%	381883

*Es posible que los porcentajes mostrados no sumen exactamente 100 debido a aproximaciones decimales.

• **Pregunta 11.**

Una agencia de turismo ofrece los siguientes precios para viajes a un determinado destino, de acuerdo con el número de personas que tomen conjuntamente el plan.

Número de personas	Valor del plan (\$)
2	600.000
3	800.000
4	1.000.000
5	1.200.000
6	1.400.000

Tabla

¿Cuál de las siguientes gráficas representa de manera correcta la relación entre el número de personas y el valor del plan?

A.

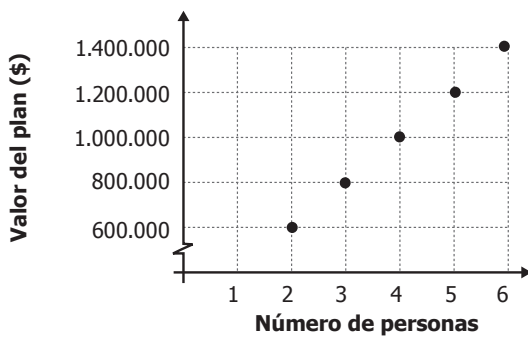

B.

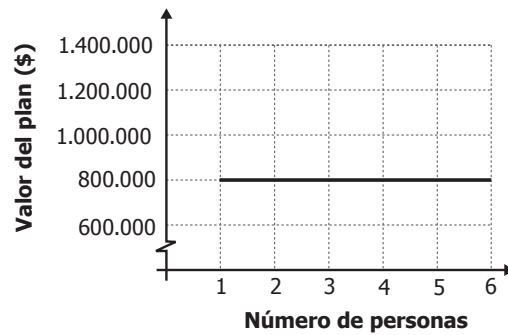

C.

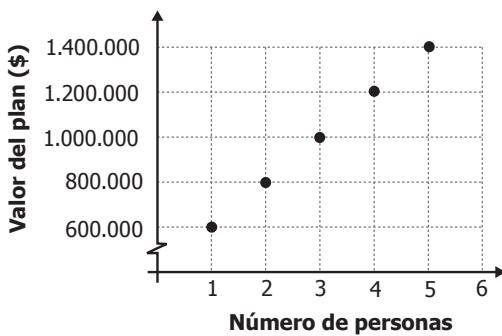

D.

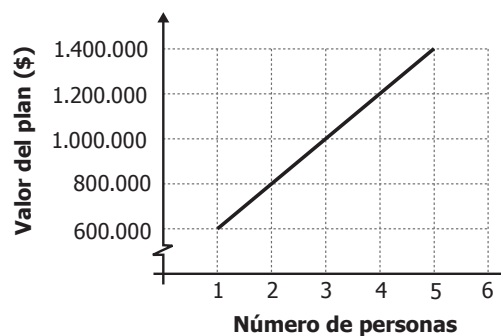

• Estructura

Competencia	Comunicación
Componente	Numérico - variacional
Afirmación	Identificar características de las graficas cartesianas en relación con la situación que representan.
Nivel de desempeño	Mínimo
Respuesta Correcta	A

• Resultados a nivel nacional y de Entidad Territorial Certificada (ETC)

ETC/País	A	B	C	D	Omisión y multimarca	Nº estudiantes
Amazonas	65.1%	13.2%	10.4%	8.1%	3.2%	627
Antioquia	72.9%	9.0%	9.7%	6.4%	2.0%	19243
Apartadó	66.5%	10.6%	13.2%	8.3%	1.4%	1088
Arauca	81.2%	5.5%	7.5%	5.2%	0.6%	1581
Armenia	78.0%	7.7%	7.7%	6.0%	0.7%	2587
Atlántico	67.8%	11.0%	11.9%	7.4%	1.8%	4931
Barrancabermeja	74.5%	8.7%	8.6%	6.9%	1.4%	1845
Barranquilla	76.8%	7.6%	8.5%	6.1%	1.1%	10591
Bello	75.1%	8.3%	8.5%	6.5%	1.6%	3032
Bogotá, D.C.	83.7%	4.7%	5.8%	5.1%	0.8%	62070
Bolívar	63.9%	12.6%	13.2%	8.0%	2.2%	7542
Boyacá	84.3%	5.1%	5.4%	4.7%	0.5%	7836
Bucaramanga	84.3%	5.0%	5.0%	4.7%	0.9%	4498
Buenaventura	67.4%	11.7%	11.4%	7.5%	2.0%	2785
Buga	77.8%	7.7%	6.9%	7.0%	0.7%	917
Caldas	76.8%	7.2%	8.7%	6.4%	0.9%	4430
Cali	77.9%	7.3%	7.8%	5.8%	1.2%	16580
Caquetá	72.8%	9.4%	10.9%	6.0%	1.0%	1658
Cartagena	69.8%	10.5%	11.0%	7.3%	1.5%	9657
Cartago	82.6%	4.9%	6.7%	5.0%	0.8%	1017
Casanare	82.4%	5.3%	6.5%	5.3%	0.5%	2177
Cauca	72.8%	8.7%	9.8%	7.0%	1.7%	8223
Cesar	70.4%	10.3%	10.9%	7.8%	0.6%	5409
Chocó	62.4%	14.7%	12.7%	8.5%	1.7%	2050
Chía	89.0%	3.0%	3.5%	3.9%	0.6%	1416
Ciénaga	60.4%	14.2%	13.8%	9.3%	2.3%	1059

Continúa en la siguiente página



ETC/País	A	B	C	D	Omisión y multimarca	N° estudiantes
Cundinamarca	84.6%	4.7%	5.6%	4.5%	0.6%	13371
Córdoba	66.1%	12.0%	11.9%	8.5%	1.5%	8943
Cúcuta	81.9%	5.9%	6.4%	5.0%	0.9%	5733
Dosquebradas	81.7%	6.6%	5.7%	5.7%	0.4%	1319
Duitama	88.3%	4.1%	3.5%	3.8%	0.3%	1251
Envigado	81.7%	5.9%	6.2%	5.5%	0.7%	1633
Facatativá	88.3%	3.1%	3.4%	4.6%	0.5%	1114
Florencia	79.6%	7.1%	6.7%	5.7%	0.9%	1382
Floridablanca	85.0%	4.9%	5.3%	3.8%	0.9%	1982
Fusagasugá	85.5%	4.2%	5.7%	4.0%	0.6%	1121
Girardot	75.8%	8.6%	7.5%	7.0%	1.2%	912
Girón	81.1%	7.0%	6.9%	4.6%	0.5%	1109
Guainía	79.2%	7.7%	3.8%	8.2%	1.1%	183
Guaviare	78.4%	8.7%	7.4%	4.8%	0.6%	621
Huila	82.7%	5.3%	6.1%	5.1%	0.8%	5194
Ibagué	81.1%	5.8%	6.7%	5.8%	0.7%	4714
Ipiales	85.1%	5.1%	4.9%	4.7%	0.3%	1066
Itagüí	69.5%	10.4%	11.0%	7.4%	1.8%	1746
Jamundí	79.8%	6.1%	8.9%	4.6%	0.6%	939
La Guajira	64.1%	13.2%	13.4%	8.2%	1.1%	2204
Lorica	62.9%	11.7%	15.6%	8.7%	1.2%	1329
Magangué	68.4%	11.2%	11.5%	7.1%	1.9%	1065
Magdalena	62.8%	13.3%	12.8%	8.9%	2.2%	5904
Maicao	70.8%	10.1%	11.0%	7.4%	0.8%	1178
Malambo	70.1%	10.9%	9.3%	8.0%	1.7%	786
Manizales	81.1%	5.4%	6.7%	6.0%	0.8%	2770
Medellín	74.6%	8.2%	9.0%	6.4%	1.8%	17124
Meta	78.6%	7.1%	8.2%	5.0%	1.1%	3789
Montería	72.8%	8.7%	10.3%	6.9%	1.2%	4177
Mosquera	87.5%	3.0%	5.4%	3.5%	0.6%	1158
Nariño	81.2%	6.4%	6.2%	5.1%	1.1%	6043
Neiva	84.9%	4.3%	5.6%	4.4%	0.8%	2951
Norte de Santander	80.8%	6.3%	6.8%	5.4%	0.7%	5090
Palmira	82.8%	4.5%	6.4%	5.3%	1.1%	2330
Pasto	86.6%	3.9%	4.8%	4.0%	0.8%	3211
Pereira	83.0%	5.1%	6.2%	5.0%	0.6%	3748
Piedecuesta	80.4%	6.0%	6.5%	5.8%	1.3%	1186
Pitalito	84.5%	4.7%	5.8%	4.4%	0.7%	1068
Popayán	82.6%	5.9%	6.1%	4.1%	1.4%	2459

Continúa en la siguiente página

ETC/País	A	B	C	D	Omisión y multimarca	N° estudiantes
Putumayo	79.0%	7.0%	7.0%	6.0%	1.0%	2703
Quibdó	60.8%	13.5%	12.4%	9.8%	3.4%	1087
Quindío	76.8%	7.7%	7.8%	6.8%	1.0%	2038
Riohacha	71.7%	9.2%	9.8%	8.0%	1.3%	1341
Rionegro	83.3%	4.0%	6.4%	5.6%	0.6%	1086
Risaralda	79.4%	7.0%	7.3%	5.5%	0.8%	1936
Sabaneta	81.3%	6.5%	4.4%	6.7%	1.2%	496
Sahagún	75.6%	8.2%	8.2%	6.9%	1.1%	1079
San Andrés	63.9%	12.9%	13.0%	9.3%	0.9%	529
Santa Marta	68.1%	11.0%	10.6%	8.4%	1.8%	4355
Santander	84.2%	4.5%	5.6%	4.9%	0.8%	6430
Sincedejo	73.5%	8.5%	10.2%	6.7%	1.1%	2695
Soacha	79.2%	6.5%	7.5%	5.7%	1.2%	4802
Sogamoso	88.5%	3.9%	3.9%	3.4%	0.2%	1267
Soledad	75.4%	8.4%	9.0%	5.8%	1.4%	4099
Sucre	67.4%	11.7%	11.9%	7.9%	1.2%	5462
Tolima	75.4%	7.8%	8.8%	6.8%	1.1%	6959
Tuluá	80.0%	5.9%	6.9%	6.0%	1.1%	1832
Tumaco	59.9%	14.8%	13.1%	9.1%	3.1%	1334
Tunja	87.1%	3.2%	5.2%	4.3%	0.2%	1740
Turbo	61.3%	13.6%	14.0%	9.6%	1.4%	1254
Uribe	69.7%	12.4%	9.1%	6.8%	2.0%	307
Valle del Cauca	77.2%	7.7%	8.1%	6.0%	0.9%	6250
Valledupar	74.1%	8.9%	8.3%	7.8%	1.0%	4092
Vichada	71.0%	12.1%	8.9%	6.7%	1.2%	404
Villavicencio	82.0%	5.7%	6.0%	5.5%	0.9%	4110
Yopal	87.0%	3.6%	5.2%	3.9%	0.4%	1395
Yumbo	79.3%	7.7%	6.5%	5.7%	0.8%	894
Zipaquirá	86.9%	2.7%	4.7%	5.4%	0.3%	1155
Colombia	77.4%	7.4%	8.0%	6.0%	1.1%	381883

*Es posible que los porcentajes mostrados no sumen exactamente 100 debido a aproximaciones decimales.

• **Pregunta 12.**

En la figura 1 se muestra la propuesta de un diseñador para la cubierta de una revista; en la figura 2 se representan, en un sistema de coordenadas cartesianas, los polígonos que conforman el diseño.



Figura 1



Figura 2

En la figura 2, los puntos $(-3, 0)$, $(-5, -6)$ y $(-1, -6)$ determinan

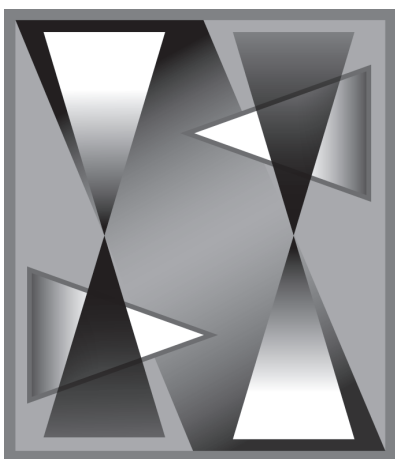
- A. el polígono 1.
- B. el polígono 2.
- C. el polígono 3.
- D. el polígono 4.

• **Estructura**

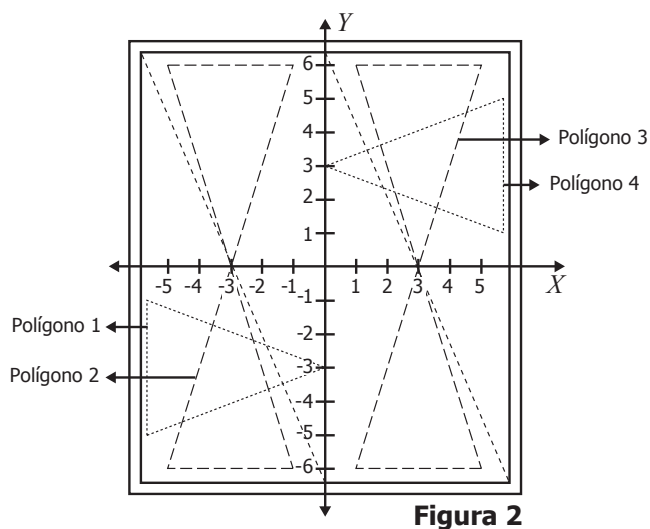
Competencia	Comunicación
Componente	Espacial - métrico
Afirmación	Usar sistemas de referencia para localizar o describir posición de objetos y figuras.
Nivel de desempeño	Satisfactorio
Respuesta Correcta	B

• Resultados a nivel nacional y de Entidad Territorial Certificada (ETC)

ETC/País	A	B	C	D	Omisión y multimarca	Nº estudiantes
Amazonas	17.9%	46.6%	22.0%	10.2%	3.3%	627
Antioquia	20.0%	51.0%	17.7%	9.2%	2.0%	19243
Apartadó	18.8%	47.9%	20.3%	11.4%	1.6%	1088
Arauca	18.0%	57.4%	15.0%	8.7%	0.9%	1581
Armenia	17.3%	57.3%	16.6%	7.8%	1.1%	2587
Atlántico	19.6%	47.5%	19.7%	11.0%	2.3%	4931
Barrancabermeja	19.8%	54.9%	16.7%	7.4%	1.2%	1845
Barranquilla	19.3%	56.2%	15.8%	7.4%	1.4%	10591
Bello	20.3%	54.3%	16.2%	7.5%	1.8%	3032
Bogotá, D.C.	17.4%	64.5%	12.3%	4.8%	0.9%	62070
Bolívar	20.8%	43.6%	21.4%	12.0%	2.2%	7542
Boyacá	19.2%	59.7%	14.4%	6.1%	0.5%	7836
Bucaramanga	16.5%	64.9%	13.2%	4.3%	1.2%	4498
Buenaventura	20.5%	46.7%	20.4%	10.4%	2.0%	2785
Buga	19.3%	59.4%	13.8%	5.9%	1.5%	917
Caldas	20.8%	53.1%	17.0%	8.1%	1.0%	4430
Cali	18.9%	57.7%	15.0%	7.0%	1.4%	16580
Caquetá	19.7%	49.5%	19.8%	10.0%	1.1%	1658
Cartagena	19.5%	49.6%	19.2%	10.0%	1.6%	9657
Cartago	20.1%	58.5%	13.3%	6.7%	1.5%	1017
Casanare	19.4%	59.9%	13.6%	6.4%	0.7%	2177
Cauca	18.9%	51.1%	18.4%	9.7%	1.8%	8223
Cesar	19.0%	51.2%	19.0%	10.0%	0.8%	5409
Chocó	19.2%	42.5%	23.5%	13.2%	1.7%	2050
Chía	16.8%	70.6%	8.1%	3.8%	0.7%	1416
Ciénaga	20.3%	41.5%	24.4%	11.7%	2.1%	1059
Cundinamarca	18.0%	62.9%	13.1%	5.3%	0.7%	13371
Córdoba	19.9%	45.4%	21.6%	11.5%	1.6%	8943
Cúcuta	19.2%	58.9%	14.5%	6.3%	1.2%	5733
Dosquebradas	18.0%	61.0%	14.6%	5.5%	0.8%	1319
Duitama	14.5%	69.9%	11.9%	3.4%	0.3%	1251
Envigado	15.7%	66.1%	11.6%	5.6%	1.0%	1633
Facatativá	15.5%	69.7%	9.8%	4.2%	0.8%	1114
Florencia	20.0%	56.7%	15.4%	6.7%	1.3%	1382
Floridablanca	14.3%	67.9%	11.3%	5.2%	1.2%	1982
Fusagasugá	19.6%	63.2%	11.3%	5.0%	0.9%	1121
Girardot	19.3%	53.2%	18.4%	7.3%	1.8%	912

Continúa en la siguiente página



ETC/País	A	B	C	D	Omisión y multimarca	N° estudiantes
Girón	20.9%	59.1%	13.3%	6.3%	0.4%	1109
Guainía	21.9%	58.5%	7.7%	11.5%	0.5%	183
Guaviare	18.7%	54.3%	17.2%	9.2%	0.6%	621
Huila	18.6%	59.2%	15.2%	6.3%	0.7%	5194
Ibagué	17.7%	60.9%	14.3%	6.1%	1.0%	4714
Ipiales	14.4%	67.7%	13.9%	3.8%	0.2%	1066
Itagüí	18.8%	51.7%	18.0%	9.7%	1.8%	1746
Jamundí	18.0%	57.3%	16.6%	6.7%	1.4%	939
La Guajira	19.8%	46.7%	19.4%	12.9%	1.2%	2204
Lorica	21.4%	42.8%	21.8%	12.6%	1.4%	1329
Magangué	21.4%	46.7%	19.1%	11.2%	1.7%	1065
Magdalena	19.8%	43.7%	22.4%	12.1%	2.0%	5904
Maicao	20.8%	48.0%	19.7%	10.8%	0.8%	1178
Malambo	19.2%	50.0%	18.8%	9.9%	2.0%	786
Manizales	17.8%	61.3%	14.4%	5.7%	0.8%	2770
Medellín	18.6%	56.1%	15.1%	8.3%	1.9%	17124
Meta	19.6%	57.2%	15.6%	6.5%	1.0%	3789
Montería	18.8%	53.9%	17.5%	8.2%	1.5%	4177
Mosquera	16.6%	66.4%	11.2%	5.1%	0.7%	1158
Nariño	17.6%	59.3%	15.0%	6.7%	1.4%	6043
Neiva	18.7%	61.9%	12.3%	5.7%	1.3%	2951
Norte de Santander	20.1%	57.5%	15.1%	6.7%	0.7%	5090
Palmira	18.5%	62.1%	12.6%	5.0%	1.7%	2330
Pasto	15.8%	66.4%	11.8%	5.1%	0.8%	3211
Pereira	18.0%	61.8%	13.8%	5.7%	0.7%	3748
Piedecuesta	18.7%	59.0%	14.8%	6.3%	1.2%	1186
Pitalito	16.9%	63.2%	13.9%	5.1%	0.8%	1068
Popayán	16.7%	62.4%	13.7%	5.2%	1.9%	2459
Putumayo	18.5%	57.4%	15.8%	7.0%	1.3%	2703
Quibdó	20.1%	41.7%	22.7%	11.1%	4.4%	1087
Quindío	18.2%	55.2%	17.3%	8.3%	1.0%	2038
Riohacha	18.5%	52.6%	17.3%	10.3%	1.3%	1341
Rionegro	19.4%	60.7%	13.3%	5.7%	0.9%	1086
Risaralda	19.1%	53.7%	18.9%	7.7%	0.7%	1936
Sabaneta	17.5%	62.1%	12.9%	6.7%	0.8%	496
Sahagún	18.9%	51.3%	19.0%	9.9%	0.8%	1079
San Andrés	18.9%	51.6%	17.0%	11.3%	1.1%	529
Santa Marta	19.8%	48.1%	20.0%	10.2%	1.9%	4355
Santander	17.7%	61.9%	14.1%	5.7%	0.7%	6430

Continúa en la siguiente página

ETC/País	A	B	C	D	Omisión y multimarca	N° estudiantes
Sincelejo	20.0%	53.3%	17.8%	7.9%	1.0%	2695
Soacha	19.2%	57.5%	15.2%	6.8%	1.3%	4802
Sogamoso	15.8%	69.2%	11.1%	3.6%	0.3%	1267
Soledad	20.7%	52.8%	15.9%	8.9%	1.6%	4099
Sucre	20.0%	46.3%	21.3%	11.1%	1.2%	5462
Tolima	19.6%	52.8%	17.4%	9.1%	1.1%	6959
Tuluá	18.0%	58.5%	14.8%	7.4%	1.3%	1832
Tumaco	21.1%	41.7%	21.2%	13.0%	3.0%	1334
Tunja	14.2%	70.9%	11.1%	3.6%	0.2%	1740
Turbo	21.6%	42.3%	21.9%	12.2%	1.9%	1254
Uribe	19.9%	48.5%	19.5%	9.8%	2.3%	307
Valle del Cauca	19.3%	54.1%	17.2%	8.2%	1.2%	6250
Valledupar	18.3%	55.3%	17.4%	8.1%	0.9%	4092
Vichada	22.5%	49.3%	17.8%	8.9%	1.5%	404
Villavicencio	17.2%	62.7%	13.6%	5.5%	1.0%	4110
Yopal	18.3%	62.2%	14.1%	4.6%	0.9%	1395
Yumbo	18.3%	59.5%	14.9%	5.9%	1.3%	894
Zipaquirá	15.8%	68.7%	11.4%	3.5%	0.6%	1155
Colombia	18.7%	56.8%	15.8%	7.5%	1.3%	381883

*Es posible que los porcentajes mostrados no sumen exactamente 100 debido a aproximaciones decimales.

• Pregunta 13.

Un grupo de 6 estudiantes de un curso está organizando un paseo y después de hacer el presupuesto, determinan que requieren en promedio \$45.000 por estudiante.

La tabla muestra la cantidad de dinero que aportó cada uno de los estudiantes.

Estudiante 1	\$23.000
Estudiante 2	\$42.000
Estudiante 3	\$42.000
Estudiante 4	\$46.000
Estudiante 5	\$47.000
Estudiante 6	\$88.000

Tabla

Con este presupuesto, ¿es posible realizar el paseo?

- A. Sí, porque el promedio del dinero recolectado es aproximadamente el doble del requerido.
- B. Sí, porque el promedio del dinero recolectado es \$3.000 mayor que el requerido.
- C. No, porque el promedio del dinero recolectado es aproximadamente la mitad del requerido.
- D. No, porque el promedio del dinero recolectado es \$3.000 menor que el requerido.

• Estructura

Competencia	Resolución
Componente	Aleatorio
Afirmación	Resolver problemas que requieran el uso e interpretación de medidas de tendencia central para analizar el comportamiento de un conjunto de datos.
Nivel de desempeño	Avanzado
Respuesta Correcta	B

• Resultados a nivel nacional y de Entidad Territorial Certificada (ETC)

ETC/País	A	B	C	D	Omisión y multimarca	Nº estudiantes
Amazonas	38.8%	29.8%	15.8%	11.6%	4.0%	627
Antioquia	33.7%	36.6%	15.9%	11.6%	2.1%	19243
Apartadó	36.2%	32.0%	17.0%	13.3%	1.5%	1088
Arauca	36.8%	38.2%	13.9%	10.5%	0.6%	1581
Armenia	31.8%	39.0%	16.5%	11.5%	1.2%	2587
Atlántico	36.5%	31.7%	17.6%	12.0%	2.3%	4931
Barrancabermeja	33.6%	36.6%	15.7%	12.4%	1.7%	1845
Barranquilla	33.8%	37.5%	15.5%	11.7%	1.4%	10591
Bello	32.8%	39.4%	15.5%	10.8%	1.6%	3032
Bogotá, D.C.	31.1%	44.3%	13.5%	10.0%	1.1%	62070
Bolívar	36.4%	29.3%	18.8%	13.4%	2.1%	7542
Boyacá	32.3%	43.4%	13.8%	9.8%	0.7%	7836
Bucaramanga	31.1%	45.6%	11.9%	10.0%	1.4%	4498
Buenaventura	35.7%	31.0%	17.9%	13.6%	1.8%	2785
Buga	33.8%	40.5%	14.5%	9.9%	1.3%	917
Caldas	34.3%	37.7%	16.3%	10.7%	1.0%	4430
Cali	34.3%	38.1%	15.0%	11.0%	1.5%	16580
Caquetá	34.7%	34.6%	17.9%	11.8%	1.0%	1658
Cartagena	33.5%	35.4%	16.9%	12.4%	1.8%	9657
Cartago	35.2%	36.8%	15.5%	11.3%	1.2%	1017
Casanare	33.9%	39.3%	14.3%	11.4%	1.1%	2177
Cauca	37.5%	32.0%	17.1%	11.6%	1.7%	8223
Cesar	35.0%	35.0%	16.9%	12.5%	0.6%	5409
Chocó	33.6%	31.8%	17.7%	15.1%	1.9%	2050
Chía	27.4%	52.0%	10.7%	8.8%	1.1%	1416
Ciénaga	39.8%	28.3%	17.2%	12.7%	1.9%	1059
Cundinamarca	31.7%	43.7%	13.5%	10.1%	1.0%	13371
Córdoba	37.3%	30.4%	18.2%	12.5%	1.6%	8943
Cúcuta	34.7%	40.0%	13.8%	10.3%	1.2%	5733
Dosquebradas	33.6%	42.1%	13.3%	10.5%	0.5%	1319
Duitama	26.4%	53.9%	9.8%	9.5%	0.4%	1251
Envigado	27.6%	48.4%	12.1%	10.8%	1.1%	1633
Facatativá	30.5%	44.3%	15.2%	8.9%	1.1%	1114
Florencia	36.1%	39.5%	12.9%	9.8%	1.7%	1382
Floridablanca	30.3%	45.6%	13.2%	9.8%	1.1%	1982
Fusagasugá	32.6%	42.9%	13.3%	10.3%	1.0%	1121
Girardot	35.7%	34.5%	17.7%	10.5%	1.5%	912

Continúa en la siguiente página



ETC/País	A	B	C	D	Omisión y multimarca	N° estudiantes
Girón	36.3%	37.8%	15.4%	10.0%	0.5%	1109
Guainía	46.4%	34.4%	11.5%	6.6%	1.1%	183
Guaviare	38.6%	36.9%	12.6%	10.5%	1.4%	621
Huila	35.8%	38.1%	15.1%	10.2%	0.8%	5194
Ibagué	32.4%	41.1%	14.5%	11.0%	1.0%	4714
Ipsiales	35.3%	43.8%	11.8%	8.6%	0.5%	1066
Itagüí	30.4%	38.7%	15.1%	14.1%	1.8%	1746
Jamundí	35.4%	37.8%	14.1%	11.6%	1.2%	939
La Guajira	37.5%	28.9%	19.7%	12.6%	1.3%	2204
Lorica	37.5%	30.3%	17.5%	12.9%	1.7%	1329
Magangué	41.2%	29.6%	16.2%	11.2%	1.9%	1065
Magdalena	38.6%	28.0%	18.3%	13.0%	2.1%	5904
Maicao	37.9%	32.0%	19.3%	9.5%	1.3%	1178
Malambo	36.9%	35.2%	16.3%	10.4%	1.1%	786
Manizales	32.3%	42.2%	14.2%	10.3%	1.0%	2770
Medellín	31.8%	38.7%	15.3%	12.2%	2.0%	17124
Meta	33.1%	38.6%	15.1%	11.7%	1.4%	3789
Montería	34.4%	36.1%	15.9%	12.0%	1.6%	4177
Mosquera	31.1%	45.2%	12.7%	10.2%	0.9%	1158
Nariño	37.6%	37.8%	13.8%	9.3%	1.5%	6043
Neiva	36.8%	39.3%	14.2%	8.4%	1.3%	2951
Norte de Santander	35.7%	38.1%	14.7%	10.7%	0.8%	5090
Palmira	35.6%	38.6%	14.2%	10.0%	1.6%	2330
Pasto	35.4%	41.7%	13.2%	8.7%	1.0%	3211
Pereira	32.4%	41.6%	14.1%	10.8%	1.1%	3748
Piedecuesta	29.1%	43.5%	13.4%	12.3%	1.7%	1186
Pitalito	32.6%	41.8%	14.7%	9.9%	1.0%	1068
Popayán	32.4%	40.7%	14.9%	10.2%	1.7%	2459
Putumayo	37.3%	36.4%	15.4%	9.5%	1.4%	2703
Quibdó	32.7%	31.1%	16.9%	15.1%	4.2%	1087
Quindío	32.7%	37.2%	16.7%	12.3%	1.0%	2038
Riohacha	37.4%	34.0%	16.6%	10.5%	1.4%	1341
Rionegro	30.8%	44.8%	14.1%	9.4%	0.8%	1086
Risaralda	36.1%	38.2%	14.7%	10.0%	1.0%	1936
Sabaneta	30.4%	43.5%	15.3%	9.7%	1.0%	496
Sahagún	36.4%	33.0%	19.0%	10.8%	0.8%	1079
San Andrés	35.7%	34.6%	17.4%	11.3%	0.9%	529
Santa Marta	36.2%	33.0%	17.1%	11.9%	1.8%	4355
Santander	33.0%	43.0%	13.0%	10.2%	0.8%	6430

Continúa en la siguiente página

ETC/País	A	B	C	D	Omisión y multimarca	N° estudiantes
Sincelejo	37.1%	32.3%	18.1%	11.5%	1.0%	2695
Soacha	34.1%	38.5%	16.0%	10.0%	1.5%	4802
Sogamoso	29.9%	47.8%	12.2%	9.6%	0.4%	1267
Soledad	35.4%	34.7%	16.9%	11.3%	1.7%	4099
Sucre	38.1%	31.1%	17.5%	12.3%	1.1%	5462
Tolima	36.5%	35.0%	16.0%	11.4%	1.1%	6959
Tuluá	32.3%	38.8%	17.4%	10.5%	1.0%	1832
Tumaco	38.1%	28.6%	18.1%	12.7%	2.5%	1334
Tunja	29.2%	47.5%	11.6%	10.9%	0.8%	1740
Turbo	36.9%	30.8%	17.1%	13.8%	1.4%	1254
Uribe	44.0%	23.8%	16.9%	12.7%	2.6%	307
Valle del Cauca	35.3%	35.4%	17.0%	10.9%	1.4%	6250
Valledupar	37.9%	33.1%	16.6%	11.4%	1.0%	4092
Vichada	38.1%	35.4%	14.1%	9.4%	3.0%	404
Villavicencio	32.0%	43.2%	14.0%	9.9%	0.9%	4110
Yopal	31.6%	46.0%	11.8%	9.6%	0.9%	1395
Yumbo	33.9%	36.0%	17.6%	10.6%	1.9%	894
Zipaquirá	30.6%	47.4%	12.1%	8.9%	0.9%	1155
Colombia	33.9%	38.6%	15.2%	11.0%	1.4%	381883

*Es posible que los porcentajes mostrados no sumen exactamente 100 debido a aproximaciones decimales.

• **Pregunta 14.**

Para instalar la televisión por cable en una casa se requiere tender un cable, tensionándolo, desde el poste alimentador hasta la conexión del televisor, como se muestra en la figura.

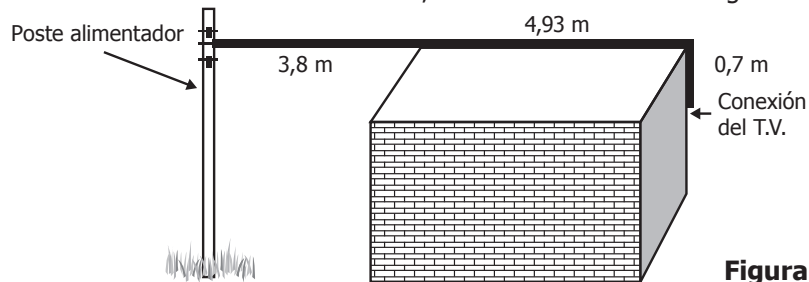

Figura

Aproximadamente ¿cuántos metros de cable se requieren para realizar la conexión?

- A. 6 m.
- B. 7 m.
- C. 8 m.
- D. 10 m.

• **Estructura**

Competencia	Resolución
Componente	N Numérico - variacional
Afirmación	Resolver y formular problemas geométricos o métricos que requieran seleccionar técnicas adecuadas de estimación o aproximación.
Nivel de desempeño	Avanzado
Respuesta Correcta	D

• Resultados a nivel nacional y de Entidad Territorial Certificada (ETC)

ETC/País	A	B	C	D	Omisión y multimarca	N° estudiantes
Amazonas	9.6%	18.3%	36.4%	32.4%	3.3%	627
Antioquia	10.6%	19.4%	35.1%	32.9%	2.0%	19243
Apartadó	14.3%	22.4%	35.2%	26.7%	1.4%	1088
Arauca	9.9%	17.1%	37.8%	34.9%	0.4%	1581
Armenia	10.2%	17.3%	35.3%	36.3%	0.9%	2587
Atlántico	11.2%	23.9%	31.6%	31.4%	2.0%	4931
Barrancabermeja	11.0%	19.1%	35.9%	33.0%	1.0%	1845
Barranquilla	11.1%	19.4%	34.8%	33.6%	1.2%	10591
Bello	11.0%	18.5%	34.5%	34.4%	1.5%	3032
Bogotá, D.C.	8.0%	14.6%	38.9%	37.4%	1.0%	62070
Bolívar	11.5%	24.7%	31.3%	30.3%	2.3%	7542
Boyacá	9.3%	14.2%	37.7%	38.1%	0.7%	7836
Bucaramanga	8.9%	13.5%	35.5%	41.0%	1.0%	4498
Buenaventura	12.3%	24.6%	33.5%	27.8%	1.8%	2785
Buga	9.7%	17.3%	34.9%	36.6%	1.4%	917
Caldas	10.2%	17.9%	36.5%	34.7%	0.7%	4430
Cali	9.9%	18.3%	35.1%	35.4%	1.3%	16580
Caquetá	10.8%	19.2%	37.3%	31.7%	0.9%	1658
Cartagena	12.0%	23.0%	33.6%	29.9%	1.5%	9657
Cartago	8.1%	17.8%	36.2%	36.5%	1.5%	1017
Casanare	10.5%	17.4%	38.3%	32.8%	1.1%	2177
Cauca	9.9%	19.7%	33.2%	35.5%	1.8%	8223
Cesar	11.2%	22.0%	33.7%	32.4%	0.7%	5409
Chocó	12.2%	25.4%	29.1%	31.4%	2.0%	2050
Chía	6.5%	9.9%	39.3%	43.4%	0.9%	1416
Ciénaga	12.5%	26.0%	30.1%	30.1%	1.3%	1059
Cundinamarca	8.4%	14.7%	38.9%	37.3%	0.8%	13371
Córdoba	11.3%	22.5%	32.8%	31.8%	1.5%	8943
Cúcuta	10.4%	16.9%	32.5%	39.2%	1.0%	5733
Dosquebradas	7.9%	13.7%	35.4%	42.1%	0.9%	1319
Duitama	8.6%	11.8%	36.3%	42.9%	0.3%	1251
Envigado	8.3%	13.3%	34.2%	43.4%	0.8%	1633
Facatativá	8.5%	14.5%	35.0%	41.2%	0.8%	1114
Florencia	11.1%	16.8%	36.1%	34.8%	1.2%	1382
Floridablanca	9.0%	13.9%	37.4%	38.6%	1.1%	1982
Fusagasugá	7.6%	13.2%	40.4%	37.6%	1.2%	1121
Girardot	10.4%	19.3%	38.5%	30.0%	1.8%	912

Continúa en la siguiente página



ETC/País	A	B	C	D	Omisión y multimarca	N° estudiantes
Girón	10.6%	18.0%	34.6%	36.4%	0.3%	1109
Guainía	7.1%	18.0%	32.8%	41.5%	0.5%	183
Guaviare	12.7%	18.8%	37.2%	30.6%	0.6%	621
Huila	9.1%	17.4%	37.8%	34.9%	0.8%	5194
Ibagué	9.7%	16.0%	36.1%	37.2%	0.9%	4714
Ipiales	10.5%	14.7%	34.3%	40.4%	0.0%	1066
Itagüí	12.8%	21.6%	34.4%	29.9%	1.3%	1746
Jamundí	10.4%	19.5%	35.9%	33.4%	0.7%	939
La Guajira	11.4%	25.9%	33.8%	27.8%	1.0%	2204
Lorica	11.4%	25.8%	32.4%	29.5%	0.8%	1329
Magangué	11.2%	23.8%	32.1%	30.5%	2.4%	1065
Magdalena	11.9%	24.7%	32.2%	29.4%	1.8%	5904
Maicao	11.1%	23.9%	33.1%	30.7%	1.1%	1178
Malambo	9.9%	20.4%	27.0%	41.5%	1.3%	786
Manizales	9.9%	16.1%	36.4%	36.7%	0.9%	2770
Medellín	10.9%	18.4%	34.5%	34.4%	1.8%	17124
Meta	9.8%	17.4%	38.3%	33.5%	1.1%	3789
Montería	11.0%	21.0%	34.1%	32.8%	1.1%	4177
Mosquera	9.5%	12.4%	39.2%	38.2%	0.7%	1158
Nariño	8.6%	16.8%	33.0%	40.3%	1.3%	6043
Neiva	9.8%	15.3%	36.7%	36.9%	1.3%	2951
Norte de Santander	10.0%	17.6%	35.3%	36.4%	0.7%	5090
Palmira	9.4%	14.8%	32.8%	41.2%	1.8%	2330
Pasto	8.5%	15.0%	34.1%	41.7%	0.7%	3211
Pereira	9.8%	14.6%	36.1%	38.7%	0.8%	3748
Piedecuesta	9.5%	17.9%	36.0%	35.2%	1.3%	1186
Pitalito	8.1%	12.8%	39.2%	38.8%	1.0%	1068
Popayán	8.5%	14.8%	36.4%	38.8%	1.5%	2459
Putumayo	9.5%	17.4%	33.3%	38.4%	1.4%	2703
Quibdó	12.9%	24.8%	33.4%	24.7%	4.2%	1087
Quindío	10.9%	19.9%	35.2%	33.0%	1.0%	2038
Riohacha	11.7%	22.6%	32.1%	32.4%	1.3%	1341
Rionegro	9.3%	14.9%	35.3%	39.9%	0.6%	1086
Risaralda	10.6%	17.1%	35.8%	35.5%	0.9%	1936
Sabaneta	9.5%	14.9%	31.3%	43.3%	1.0%	496
Sahagún	9.3%	23.7%	35.5%	30.8%	0.7%	1079
San Andrés	11.2%	23.4%	36.3%	27.8%	1.3%	529
Santa Marta	10.8%	20.6%	35.4%	31.2%	2.0%	4355
Santander	8.9%	14.5%	36.9%	39.0%	0.6%	6430

Continúa en la siguiente página

ETC/País	A	B	C	D	Omisión y multimarca	N° estudiantes
Sincelejo	11.8%	20.8%	32.8%	33.5%	1.0%	2695
Soacha	9.8%	18.8%	37.9%	32.2%	1.3%	4802
Sogamoso	9.5%	12.5%	34.5%	43.1%	0.4%	1267
Soledad	11.7%	20.9%	34.8%	30.9%	1.7%	4099
Sucre	10.9%	22.9%	32.3%	32.9%	1.0%	5462
Tolima	10.3%	18.8%	36.2%	33.7%	1.1%	6959
Tuluá	9.2%	17.2%	37.7%	34.7%	1.3%	1832
Tumaco	11.5%	24.1%	30.0%	32.2%	2.2%	1334
Tunja	8.1%	11.6%	39.8%	40.0%	0.5%	1740
Turbo	11.7%	25.0%	33.7%	27.7%	2.0%	1254
Uribe	11.4%	27.7%	30.0%	29.0%	2.0%	307
Valle del Cauca	9.9%	17.9%	35.7%	35.3%	1.2%	6250
Valledupar	11.6%	21.6%	34.8%	30.9%	1.1%	4092
Vichada	9.4%	19.6%	32.2%	36.4%	2.5%	404
Villavicencio	8.7%	16.4%	36.5%	37.6%	0.9%	4110
Yopal	8.3%	15.1%	38.6%	37.1%	0.9%	1395
Yumbo	10.2%	16.9%	35.8%	36.0%	1.1%	894
Zipaquirá	7.6%	12.6%	40.5%	38.6%	0.7%	1155
Colombia	9.9%	18.0%	35.7%	35.1%	1.2%	381883

*Es posible que los porcentajes mostrados no sumen exactamente 100 debido a aproximaciones decimales.

• **Pregunta 15.**

* Usando una bomba se va a pasar agua del tanque 1 al tanque 2 que está vacío (ver figura). El agua que está en el tanque 1 alcanza una altura de 1.200 mm. A partir del momento en que se enciende la bomba, la altura del tanque 1 disminuye 10 mm por minuto y la del tanque 2 aumenta 50 mm por minuto.

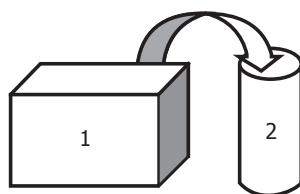

Figura

¿Cuál expresión permite encontrar los minutos (x) que deben transcurrir, a partir del momento en que se enciende la bomba, para que la altura del agua en los dos tanques sea la misma?

- A. $1200 - 10x = 50x$
- B. $1200 + 30x = 30x$
- C. $x + x = 50 + 10$
- D. $600 - x = x$

• **Estructura**

Competencia	Resolución
Componente	Numérico - variacional
Afirmación	Resolver problemas en situaciones de variación con funciones polinómicas y exponenciales en contextos aritméticos y geométricos.
Nivel de desempeño	Satisfactorio
Respuesta Correcta	A

• Resultados a nivel nacional y de Entidad Territorial Certificada (ETC)

ETC/País	A	B	C	D	Omisión y multimarca	N° estudiantes
Amazonas	36.0%	29.0%	20.4%	9.1%	5.4%	627
Antioquia	43.8%	25.3%	19.1%	9.5%	2.4%	19243
Apartadó	41.6%	26.4%	18.5%	11.7%	1.8%	1088
Arauca	45.2%	25.9%	19.2%	8.4%	1.3%	1581
Armenia	45.7%	25.9%	18.1%	9.0%	1.3%	2587
Atlántico	43.9%	24.8%	19.4%	9.6%	2.3%	4931
Barrancabermeja	47.6%	23.9%	18.2%	8.5%	1.8%	1845
Barranquilla	50.9%	21.5%	17.4%	8.5%	1.8%	10591
Bello	46.2%	23.0%	20.0%	8.7%	2.0%	3032
Bogotá, D.C.	53.2%	21.8%	16.3%	7.2%	1.4%	62070
Bolívar	38.6%	28.0%	20.3%	10.7%	2.5%	7542
Boyacá	49.3%	23.0%	18.2%	8.7%	0.8%	7836
Bucaramanga	54.0%	20.9%	16.4%	7.1%	1.6%	4498
Buenaventura	42.6%	24.6%	19.7%	10.7%	2.5%	2785
Buga	49.7%	24.0%	15.6%	9.2%	1.5%	917
Caldas	44.7%	26.0%	18.7%	9.4%	1.3%	4430
Cali	49.6%	23.0%	17.0%	8.1%	2.2%	16580
Caquetá	40.8%	28.0%	20.0%	10.2%	1.0%	1658
Cartagena	45.6%	24.3%	18.7%	9.5%	2.0%	9657
Cartago	50.3%	21.8%	18.2%	8.0%	1.7%	1017
Casanare	46.0%	26.0%	17.9%	8.8%	1.4%	2177
Cauca	43.8%	26.1%	18.9%	9.3%	2.0%	8223
Cesar	42.0%	24.8%	22.1%	9.8%	1.3%	5409
Chocó	38.8%	26.0%	21.3%	11.6%	2.3%	2050
Chía	58.7%	18.6%	14.5%	6.8%	1.4%	1416
Ciénaga	39.4%	25.6%	21.2%	11.0%	2.8%	1059
Cundinamarca	51.6%	22.6%	16.8%	7.8%	1.1%	13371
Córdoba	40.4%	27.9%	20.5%	9.3%	1.8%	8943
Cúcuta	52.3%	21.3%	16.8%	8.1%	1.5%	5733
Dosquebradas	50.4%	21.2%	18.6%	8.8%	1.1%	1319
Duitama	59.0%	18.1%	14.5%	7.9%	0.4%	1251
Envigado	56.6%	18.4%	15.2%	8.5%	1.2%	1633
Facatativá	57.5%	19.7%	17.0%	4.9%	0.9%	1114
Florencia	50.0%	21.9%	18.2%	8.1%	1.8%	1382
Floridablanca	58.5%	18.1%	14.1%	7.3%	2.0%	1982
Fusagasugá	50.8%	24.1%	18.5%	5.5%	1.2%	1121
Girardot	45.5%	25.1%	19.1%	8.4%	1.9%	912

Continúa en la siguiente página



ETC/País	A	B	C	D	Omisión y multimarca	N° estudiantes
Girón	50.5%	23.1%	18.9%	6.6%	0.9%	1109
Guainía	49.2%	26.8%	17.5%	5.5%	1.1%	183
Guaviare	42.7%	27.4%	19.6%	9.0%	1.3%	621
Huila	48.0%	24.2%	17.9%	8.7%	1.2%	5194
Ibagué	51.8%	22.4%	16.5%	8.0%	1.3%	4714
Ipiales	50.4%	23.6%	18.0%	7.1%	0.8%	1066
Itagüí	43.5%	24.4%	19.9%	10.0%	2.2%	1746
Jamundí	45.3%	24.7%	19.0%	8.7%	2.3%	939
La Guajira	40.2%	27.6%	19.5%	11.2%	1.6%	2204
Lorica	37.5%	30.5%	19.4%	11.1%	1.4%	1329
Magangué	42.6%	24.4%	19.8%	10.4%	2.7%	1065
Magdalena	37.9%	27.6%	21.1%	10.9%	2.5%	5904
Maicao	45.3%	24.6%	18.9%	10.2%	0.9%	1178
Malambo	45.3%	24.0%	20.2%	9.4%	1.0%	786
Manizales	48.4%	24.0%	18.1%	8.2%	1.3%	2770
Medellín	46.4%	23.6%	18.8%	8.8%	2.3%	17124
Meta	45.5%	25.7%	18.1%	9.0%	1.7%	3789
Montería	44.4%	25.9%	18.9%	9.2%	1.7%	4177
Mosquera	52.7%	21.7%	17.7%	6.7%	1.2%	1158
Nariño	48.6%	22.7%	18.5%	8.4%	1.7%	6043
Neiva	53.5%	21.8%	15.4%	7.8%	1.5%	2951
Norte de Santander	49.0%	23.4%	18.2%	8.3%	1.0%	5090
Palmira	54.0%	20.6%	16.1%	7.3%	2.1%	2330
Pasto	54.0%	21.0%	16.6%	7.1%	1.3%	3211
Pereira	50.4%	23.3%	17.2%	8.1%	1.0%	3748
Piedecuesta	50.8%	21.6%	16.5%	8.8%	2.3%	1186
Pitalito	52.9%	21.8%	15.1%	9.2%	1.0%	1068
Popayán	53.2%	20.7%	16.8%	7.3%	2.0%	2459
Putumayo	47.2%	23.7%	18.9%	8.3%	1.9%	2703
Quibdó	35.6%	27.2%	21.3%	10.9%	4.9%	1087
Quindío	44.0%	26.4%	19.2%	9.0%	1.4%	2038
Riohacha	44.7%	23.6%	19.6%	9.9%	2.1%	1341
Rionegro	55.2%	20.8%	16.2%	7.1%	0.7%	1086
Risaralda	44.4%	26.7%	19.1%	8.3%	1.6%	1936
Sabaneta	54.4%	20.8%	15.1%	8.5%	1.2%	496
Sahagún	46.1%	25.6%	18.0%	9.5%	0.9%	1079
San Andrés	40.3%	27.4%	19.7%	11.7%	0.9%	529
Santa Marta	43.1%	24.8%	20.1%	9.3%	2.6%	4355
Santander	50.6%	22.4%	17.6%	8.4%	1.0%	6430

Continúa en la siguiente página

ETC/País	A	B	C	D	Omisión y multimarca	N° estudiantes
Sincelejo	46.7%	25.2%	18.5%	8.3%	1.3%	2695
Soacha	47.2%	24.9%	18.0%	8.2%	1.6%	4802
Sogamoso	58.9%	19.4%	15.7%	5.4%	0.6%	1267
Soledad	46.8%	23.5%	18.0%	9.6%	2.1%	4099
Sucre	42.9%	26.7%	19.6%	9.5%	1.4%	5462
Tolima	44.5%	25.7%	18.8%	9.7%	1.5%	6959
Tuluá	47.9%	23.4%	18.5%	8.6%	1.7%	1832
Tumaco	35.7%	29.6%	20.3%	11.0%	3.4%	1334
Tunja	54.9%	21.5%	15.8%	7.1%	0.7%	1740
Turbo	38.4%	29.3%	21.7%	8.5%	2.0%	1254
Uribe	36.5%	29.3%	19.2%	11.7%	3.3%	307
Valle del Cauca	45.7%	26.4%	17.9%	8.3%	1.6%	6250
Valledupar	47.7%	23.3%	18.5%	9.1%	1.5%	4092
Vichada	36.1%	29.2%	19.6%	10.6%	4.5%	404
Villavicencio	51.3%	22.3%	17.0%	8.1%	1.3%	4110
Yopal	51.8%	23.3%	15.4%	8.4%	1.1%	1395
Yumbo	49.4%	22.9%	17.7%	8.3%	1.7%	894
Zipaquirá	59.7%	20.0%	13.3%	6.3%	0.6%	1155
Colombia	48.0%	23.7%	18.0%	8.6%	1.7%	381883

*Es posible que los porcentajes mostrados no sumen exactamente 100 debido a aproximaciones decimales.

• **Pregunta 16.**

El cajero de un banco tiene al iniciar la jornada \$88.000 en monedas de \$100, \$200 y \$500; se sabe que tiene 110 monedas de \$500.

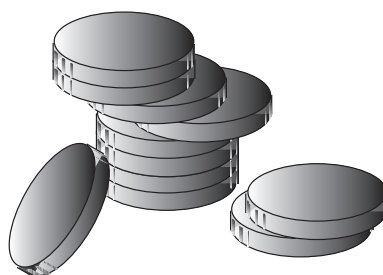

Si había en total 320 monedas. ¿Cuántas monedas de \$100 y \$200, respectivamente, podría tener el cajero?

- A. 110 y 150.
- B. 100 y 200.
- C. 90 y 120.
- D. 50 y 50.

• **Estructura**

Competencia	Resolución
Componente	Numérico - variacional
Afirmación	Resolver problemas en situaciones de variación con funciones polinómicas y exponenciales en contextos aritméticos y geométricos
Nivel de desempeño	Satisfactorio
Respuesta Correcta	C

• Resultados a nivel nacional y de Entidad Territorial Certificada (ETC)

ETC/País	A	B	C	D	Omisión y multimarca	N° estudiantes
Amazonas	19.3%	27.6%	39.2%	8.6%	5.3%	627
Antioquia	18.0%	22.8%	48.4%	8.8%	2.0%	19243
Apartadó	19.7%	22.9%	44.8%	11.2%	1.5%	1088
Arauca	17.0%	21.7%	52.4%	7.8%	1.1%	1581
Armenia	18.7%	21.9%	49.3%	8.9%	1.2%	2587
Atlántico	18.2%	25.9%	42.9%	10.7%	2.2%	4931
Barrancabermeja	17.7%	22.4%	49.2%	9.2%	1.6%	1845
Barranquilla	16.7%	21.3%	51.6%	8.7%	1.7%	10591
Bello	17.5%	22.0%	50.3%	8.2%	1.9%	3032
Bogotá, D.C.	15.5%	18.9%	57.6%	6.7%	1.3%	62070
Bolívar	19.6%	26.7%	40.6%	10.5%	2.6%	7542
Boyacá	15.0%	21.3%	56.6%	6.4%	0.7%	7836
Bucaramanga	14.1%	18.5%	59.5%	6.4%	1.4%	4498
Buenaventura	18.1%	25.4%	43.9%	10.5%	2.0%	2785
Buga	13.5%	23.1%	52.1%	9.8%	1.4%	917
Caldas	18.2%	25.3%	47.0%	8.3%	1.2%	4430
Calí	17.2%	21.8%	50.9%	8.3%	1.8%	16580
Caquetá	20.7%	24.5%	44.6%	9.0%	1.1%	1658
Cartagena	18.0%	23.7%	46.6%	9.9%	1.9%	9657
Cartago	16.9%	23.0%	49.2%	9.2%	1.7%	1017
Casanare	16.9%	22.1%	52.9%	7.2%	1.0%	2177
Cauca	18.4%	28.0%	43.4%	8.3%	1.9%	8223
Cesar	18.5%	24.3%	46.2%	10.0%	1.0%	5409
Chocó	18.3%	30.1%	38.6%	10.7%	2.2%	2050
Chía	13.9%	17.9%	61.1%	6.0%	1.1%	1416
Ciénaga	22.9%	27.7%	36.8%	10.4%	2.2%	1059
Cundinamarca	15.2%	21.2%	55.7%	6.8%	1.1%	13371
Córdoba	19.6%	26.3%	41.7%	10.7%	1.7%	8943
Cúcuta	15.0%	21.2%	54.8%	7.7%	1.3%	5733
Dosquebradas	15.3%	21.5%	53.8%	8.5%	0.9%	1319
Duitama	12.7%	17.3%	65.0%	4.7%	0.3%	1251
Envigado	12.2%	16.4%	61.7%	8.5%	1.2%	1633
Facatativá	12.8%	18.0%	62.3%	6.0%	0.9%	1114
Florencia	17.0%	22.0%	51.7%	8.2%	1.1%	1382
Floridablanca	13.8%	16.2%	62.6%	6.1%	1.3%	1982
Fusagasugá	17.0%	18.0%	57.2%	6.5%	1.2%	1121
Girardot	19.0%	24.0%	47.5%	7.6%	2.0%	912

Continúa en la siguiente página



ETC/País	A	B	C	D	Omisión y multimarca	N° estudiantes
Girón	18.1%	20.3%	52.8%	8.3%	0.5%	1109
Guainía	19.7%	27.3%	44.8%	7.1%	1.1%	183
Guaviare	16.7%	23.2%	48.8%	9.5%	1.8%	621
Huila	17.8%	25.0%	49.7%	6.4%	1.1%	5194
Ibagué	16.3%	21.1%	53.3%	8.3%	0.9%	4714
Ipiales	14.3%	18.2%	57.9%	9.1%	0.6%	1066
Itagüí	18.2%	20.7%	50.5%	9.1%	1.5%	1746
Jamundí	17.8%	22.3%	50.6%	7.7%	1.7%	939
La Guajira	20.3%	26.8%	38.9%	12.6%	1.5%	2204
Lorica	22.6%	28.5%	36.4%	11.3%	1.1%	1329
Magangué	20.8%	24.4%	41.5%	11.1%	2.2%	1065
Magdalena	20.4%	27.1%	39.9%	10.4%	2.3%	5904
Maicao	20.3%	24.7%	43.9%	9.8%	1.4%	1178
Malambo	17.0%	20.9%	52.8%	7.8%	1.5%	786
Manizales	16.5%	22.2%	52.2%	8.1%	1.1%	2770
Medellín	17.5%	21.3%	50.2%	9.0%	2.0%	17124
Meta	18.5%	22.3%	49.7%	8.0%	1.5%	3789
Montería	17.7%	23.4%	47.6%	9.7%	1.6%	4177
Mosquera	14.5%	19.4%	58.5%	6.4%	1.2%	1158
Nariño	15.8%	22.1%	52.9%	7.7%	1.5%	6043
Neiva	16.0%	20.7%	54.8%	7.0%	1.5%	2951
Norte de Santander	16.9%	21.8%	52.0%	8.4%	0.8%	5090
Palmira	14.5%	20.5%	55.5%	7.7%	1.8%	2330
Pasto	14.9%	19.5%	57.7%	6.9%	1.0%	3211
Pereira	16.2%	21.1%	53.7%	7.9%	1.1%	3748
Piedecuesta	14.8%	17.5%	58.7%	7.8%	1.3%	1186
Pitalito	19.3%	20.4%	53.7%	5.8%	0.8%	1068
Popayán	15.5%	18.6%	56.0%	8.0%	1.9%	2459
Putumayo	15.6%	22.9%	52.3%	7.5%	1.6%	2703
Quibdó	19.3%	24.3%	38.8%	12.9%	4.7%	1087
Quindío	19.0%	23.8%	47.0%	8.8%	1.4%	2038
Riohacha	16.5%	23.8%	49.0%	9.2%	1.6%	1341
Rionegro	13.2%	20.8%	57.9%	7.4%	0.7%	1086
Risaralda	19.0%	25.5%	46.6%	7.9%	1.0%	1936
Sabaneta	11.7%	15.1%	62.7%	8.5%	2.0%	496
Sahagún	17.0%	23.6%	48.1%	10.1%	1.2%	1079
San Andrés	21.6%	27.6%	37.8%	11.7%	1.3%	529
Santa Marta	18.4%	24.1%	45.9%	9.4%	2.2%	4355
Santander	14.1%	20.3%	57.9%	6.8%	0.8%	6430

Continúa en la siguiente página

ETC/País	A	B	C	D	Omisión y multimarca	Nº estudiantes
Sincelejo	16.6%	23.9%	47.3%	11.1%	1.2%	2695
Soacha	17.5%	20.1%	53.4%	7.6%	1.5%	4802
Sogamoso	12.0%	18.0%	63.4%	6.3%	0.3%	1267
Soledad	17.2%	21.6%	49.2%	9.9%	2.1%	4099
Sucre	19.5%	27.2%	40.6%	11.4%	1.3%	5462
Tolima	18.2%	26.0%	46.3%	8.1%	1.4%	6959
Tuluá	16.6%	21.2%	51.6%	9.2%	1.4%	1832
Tumaco	20.2%	27.8%	39.0%	9.7%	3.2%	1334
Tunja	12.9%	18.0%	62.5%	5.9%	0.7%	1740
Turbo	20.9%	26.3%	39.7%	11.5%	1.6%	1254
Uribe	24.1%	31.9%	33.2%	8.5%	2.3%	307
Valle del Cauca	18.5%	22.9%	47.7%	9.6%	1.3%	6250
Valledupar	18.4%	23.6%	47.5%	9.2%	1.2%	4092
Vichada	19.1%	29.0%	41.1%	6.4%	4.5%	404
Villavicencio	15.1%	20.4%	55.6%	7.6%	1.3%	4110
Yopal	15.0%	20.8%	56.2%	7.3%	0.7%	1395
Yumbo	18.2%	23.3%	48.5%	8.3%	1.7%	894
Zipaquirá	10.6%	17.0%	65.0%	6.5%	0.9%	1155
Colombia	16.9%	22.1%	51.1%	8.3%	1.5%	381883

*Es posible que los porcentajes mostrados no sumen exactamente 100 debido a aproximaciones decimales.

• **Pregunta 17.**

En la figura, las rectas h y j son paralelas, y los triángulos LPR y OPS son congruentes.

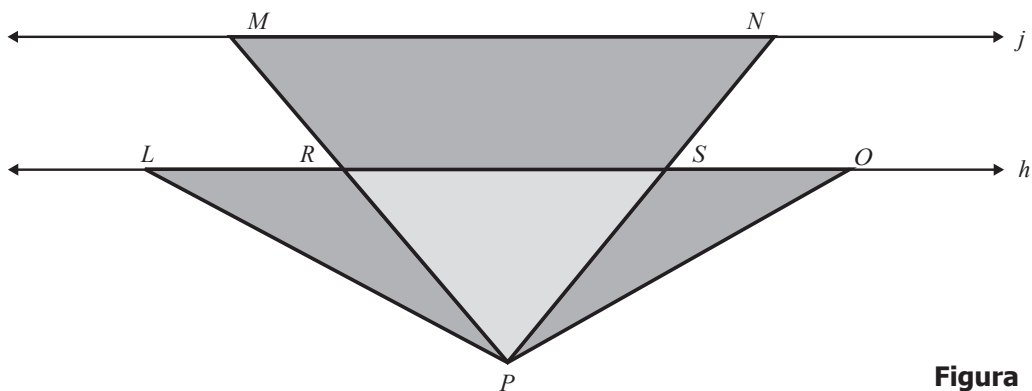

Figura

Con la información anterior **NO** es correcto afirmar que

- A. $\frac{PR}{PM} = \frac{PS}{PN}$.
- B. $RP = SO$.
- C. $\frac{PM}{PN} = \frac{PR}{PS}$.
- D. $MR = NS$.

• **Estructura**

Competencia	Razonamiento
Componente	Espacial - métrico
Afirmación	Hacer conjeturas y verificar propiedades de congruencia y semejanza entre figuras bidimensionales.
Nivel de desempeño	Satisfactorio
Respuesta Correcta	B

• Resultados a nivel nacional y de Entidad Territorial Certificada (ETC)

ETC/País	A	B	C	D	Omisión y multimarca	N° estudiantes
Amazonas	22.0%	34.0%	23.4%	16.3%	4.3%	627
Antioquia	21.0%	42.9%	20.0%	14.0%	2.1%	19243
Apartadó	25.2%	42.3%	17.9%	13.2%	1.4%	1088
Arauca	20.1%	45.2%	20.6%	13.7%	0.5%	1581
Armenia	19.1%	47.7%	19.9%	12.3%	1.0%	2587
Atlántico	23.5%	39.6%	21.3%	13.9%	1.8%	4931
Barrancabermeja	21.6%	46.3%	19.1%	11.9%	1.1%	1845
Barranquilla	21.5%	47.7%	17.6%	11.9%	1.3%	10591
Bello	22.7%	45.3%	18.4%	11.8%	1.7%	3032
Bogotá, D.C.	16.9%	52.7%	18.2%	10.7%	1.4%	62070
Bolívar	25.3%	36.9%	21.0%	14.8%	2.1%	7542
Boyacá	15.9%	50.8%	20.0%	12.5%	0.8%	7836
Bucaramanga	15.7%	57.6%	16.4%	8.9%	1.5%	4498
Buenaventura	23.4%	40.4%	19.6%	14.8%	1.8%	2785
Buga	18.5%	51.9%	18.8%	9.5%	1.3%	917
Caldas	19.2%	44.1%	20.9%	14.9%	0.9%	4430
Cali	20.2%	48.6%	17.8%	11.6%	1.7%	16580
Caquetá	21.8%	39.0%	22.7%	15.7%	0.8%	1658
Cartagena	24.9%	42.1%	19.1%	12.4%	1.5%	9657
Cartago	16.9%	50.2%	19.8%	11.2%	1.9%	1017
Casanare	18.6%	44.8%	22.3%	13.4%	0.9%	2177
Cauca	20.3%	40.6%	22.3%	15.0%	1.8%	8223
Cesar	21.6%	43.1%	20.2%	14.3%	0.8%	5409
Chocó	22.4%	38.0%	20.6%	17.1%	1.9%	2050
Chía	12.9%	59.1%	17.0%	9.8%	1.2%	1416
Ciénaga	27.1%	33.3%	24.1%	13.5%	2.0%	1059
Cundinamarca	17.0%	50.2%	19.8%	12.0%	1.1%	13371
Córdoba	22.3%	40.3%	20.3%	15.6%	1.4%	8943
Cúcuta	19.1%	50.2%	18.3%	11.3%	1.2%	5733
Dosquebradas	18.2%	48.4%	21.8%	10.8%	0.8%	1319
Duitama	14.5%	60.3%	16.5%	8.2%	0.5%	1251
Envigado	15.9%	59.5%	14.8%	9.0%	0.9%	1633
Facatativá	14.1%	53.3%	18.0%	13.6%	1.0%	1114
Florencia	17.7%	45.7%	21.3%	13.7%	1.7%	1382
Floridablanca	14.9%	57.7%	17.3%	8.9%	1.2%	1982
Fusagasugá	16.7%	50.6%	20.4%	11.0%	1.3%	1121
Girardot	20.9%	43.5%	21.7%	12.2%	1.6%	912

Continúa en la siguiente página



ETC/País	A	B	C	D	Omisión y multimarca	N° estudiantes
Girón	20.0%	50.0%	18.9%	10.4%	0.6%	1109
Guainía	20.2%	38.3%	21.9%	19.1%	0.5%	183
Guaviare	21.3%	41.4%	20.9%	15.0%	1.4%	621
Huila	17.8%	46.9%	21.2%	13.1%	1.0%	5194
Ibagué	18.8%	48.0%	19.7%	12.4%	1.1%	4714
Ipiales	18.3%	52.2%	18.8%	10.6%	0.2%	1066
Itagüí	23.7%	44.3%	18.0%	12.2%	1.8%	1746
Jamundí	21.5%	46.1%	18.5%	13.0%	0.9%	939
La Guajira	26.9%	35.6%	21.8%	14.6%	1.2%	2204
Lorica	26.9%	35.6%	21.4%	15.0%	1.1%	1329
Magangué	23.4%	38.5%	20.8%	15.1%	2.3%	1065
Magdalena	23.2%	37.9%	21.7%	15.4%	1.8%	5904
Maicao	23.3%	40.4%	21.0%	14.5%	0.8%	1178
Malambo	26.0%	43.3%	18.3%	12.0%	0.5%	786
Manizales	19.1%	48.8%	19.3%	11.7%	1.1%	2770
Medellín	21.3%	46.9%	18.0%	11.9%	1.9%	17124
Meta	19.6%	43.8%	22.6%	12.6%	1.4%	3789
Montería	20.8%	46.2%	19.7%	12.1%	1.3%	4177
Mosquera	14.6%	54.1%	19.1%	11.2%	1.0%	1158
Nariño	16.1%	47.3%	20.8%	14.3%	1.4%	6043
Neiva	18.3%	53.0%	17.0%	10.2%	1.5%	2951
Norte de Santander	18.3%	47.1%	20.3%	13.4%	0.8%	5090
Palmira	14.5%	55.0%	17.4%	11.1%	2.0%	2330
Pasto	15.5%	53.3%	19.0%	11.3%	0.9%	3211
Pereira	17.5%	50.1%	19.9%	11.5%	1.0%	3748
Piedecuesta	17.6%	48.4%	19.8%	12.6%	1.5%	1186
Pitalito	16.3%	54.8%	16.8%	11.2%	0.9%	1068
Popayán	16.4%	53.4%	18.0%	10.4%	1.8%	2459
Putumayo	18.3%	45.3%	21.2%	13.5%	1.7%	2703
Quibdó	24.8%	32.8%	22.8%	15.5%	4.1%	1087
Quindío	22.2%	42.4%	20.9%	13.6%	0.9%	2038
Riohacha	21.6%	42.4%	20.1%	14.4%	1.4%	1341
Rionegro	18.3%	55.3%	16.9%	8.5%	0.9%	1086
Risaralda	19.7%	42.1%	24.2%	12.8%	1.1%	1936
Sabaneta	14.3%	57.3%	17.5%	9.7%	1.2%	496
Sahagún	20.7%	43.7%	21.3%	13.7%	0.6%	1079
San Andrés	28.0%	39.3%	18.0%	14.2%	0.6%	529
Santa Marta	23.3%	40.1%	19.6%	15.1%	1.9%	4355
Santander	17.3%	51.2%	19.3%	11.4%	0.8%	6430

Continúa en la siguiente página

ETC/País	A	B	C	D	Omisión y multimarca	N° estudiantes
Sincelejo	24.6%	42.9%	19.3%	12.3%	0.9%	2695
Soacha	20.7%	45.5%	19.5%	12.9%	1.4%	4802
Sogamoso	15.4%	58.0%	15.9%	10.3%	0.4%	1267
Soledad	23.0%	44.3%	18.3%	12.6%	1.7%	4099
Sucre	21.6%	41.0%	21.7%	14.7%	1.0%	5462
Tolima	20.0%	41.1%	22.7%	14.9%	1.3%	6959
Tuluá	18.6%	45.4%	20.3%	14.2%	1.6%	1832
Tumaco	24.3%	32.2%	24.4%	16.4%	2.6%	1334
Tunja	14.1%	58.2%	16.3%	10.6%	0.8%	1740
Turbo	27.5%	35.1%	20.3%	15.5%	1.6%	1254
Uribe	20.2%	43.3%	21.8%	12.7%	2.0%	307
Valle del Cauca	20.9%	44.9%	19.6%	13.3%	1.2%	6250
Valledupar	22.9%	44.3%	18.7%	12.8%	1.2%	4092
Vichada	20.8%	40.8%	20.3%	14.4%	3.7%	404
Villavicencio	19.1%	49.0%	19.3%	11.4%	1.2%	4110
Yopal	18.6%	48.9%	21.2%	10.5%	0.9%	1395
Yumbo	18.6%	48.8%	18.8%	12.0%	1.9%	894
Zipaquirá	13.6%	55.4%	17.7%	12.4%	0.9%	1155
Colombia	19.7%	46.9%	19.5%	12.5%	1.4%	381883

*Es posible que los porcentajes mostrados no sumen exactamente 100 debido a aproximaciones decimales.

• **Pregunta 18.**

En un concurso hay una urna con 2 fichas rojas y 2 fichas blancas. Un jugador selecciona al azar una ficha de la urna, sin devolver esta. Luego, selecciona al azar una segunda ficha. Si tiene el mismo color de la primera gana el juego.

¿En cuál de los siguientes diagramas se representan las posibilidades de ganar que tiene un jugador?

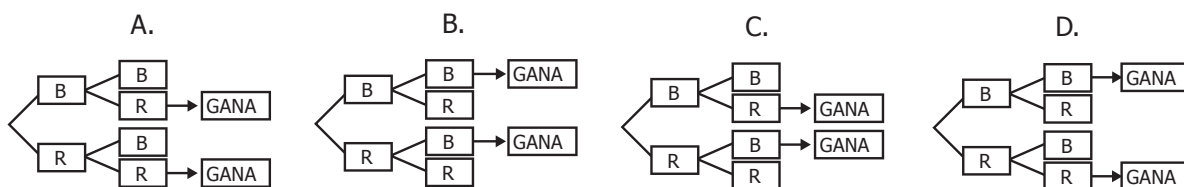

• **Estructura**

Competencia	Razonamiento
Componente	Aleatorio
Afirmación	Usar modelos para discutir acerca de la probabilidad de un evento aleatorio.
Nivel de desempeño	Avanzado
Respuesta Correcta	D

• **Resultados a nivel nacional y de Entidad Territorial Certificada (ETC)**

ETC/País	A	B	C	D	Omisión y multimarca	Nº estudiantes
Amazonas	18.3%	30.8%	23.1%	22.2%	5.6%	627
Antioquia	19.6%	31.2%	22.6%	24.2%	2.5%	19243
Apartadó	21.3%	29.3%	24.2%	23.3%	1.8%	1088
Arauca	20.7%	31.1%	21.7%	25.3%	1.3%	1581
Armenia	20.4%	28.4%	20.2%	29.6%	1.4%	2587
Atlántico	19.2%	30.9%	22.2%	25.1%	2.5%	4931
Barrancabermeja	19.4%	28.6%	22.9%	27.4%	1.8%	1845
Barranquilla	19.3%	29.9%	19.3%	29.6%	2.0%	10591
Bello	20.3%	30.1%	18.9%	28.3%	2.4%	3032
Bogotá, D.C.	17.8%	28.6%	18.5%	33.4%	1.7%	62070
Bolívar	20.0%	31.1%	24.9%	21.1%	2.9%	7542
Boyacá	18.1%	33.6%	20.3%	27.0%	1.0%	7836
Bucaramanga	17.3%	28.6%	17.5%	34.5%	2.0%	4498
Buenaventura	18.6%	32.0%	23.1%	23.7%	2.7%	2785

Continúa en la siguiente página

SABER 9 - MATEMÁTICAS

ETC/País	A	B	C	D	Omisión y multimarca	N° estudiantes
Buga	19.8%	30.5%	19.0%	29.1%	1.5%	917
Caldas	19.6%	33.6%	22.9%	22.6%	1.3%	4430
Cali	19.9%	29.2%	18.9%	29.7%	2.3%	16580
Caquetá	19.2%	32.8%	23.6%	22.4%	2.1%	1658
Cartagena	19.9%	30.3%	21.8%	25.8%	2.2%	9657
Cartago	19.3%	29.4%	18.6%	30.5%	2.3%	1017
Casanare	16.8%	34.9%	22.5%	24.4%	1.5%	2177
Cauca	19.8%	32.8%	22.9%	22.0%	2.4%	8223
Cesar	19.6%	31.3%	23.6%	24.3%	1.1%	5409
Chocó	20.3%	31.0%	25.9%	20.8%	2.0%	2050
Chía	16.0%	27.2%	15.8%	39.0%	2.0%	1416
Ciénaga	19.5%	31.7%	23.7%	22.0%	3.0%	1059
Cundinamarca	18.4%	31.4%	19.6%	29.2%	1.4%	13371
Córdoba	19.5%	32.1%	24.2%	22.1%	2.1%	8943
Cúcuta	20.5%	30.2%	18.9%	29.0%	1.4%	5733
Dosquebradas	18.7%	31.5%	18.3%	30.6%	0.8%	1319
Duitama	17.7%	27.0%	16.7%	37.8%	0.8%	1251
Envigado	18.8%	25.1%	15.1%	39.8%	1.2%	1633
Facatativá	17.5%	33.4%	16.3%	31.8%	1.0%	1114
Florencia	19.9%	32.4%	19.3%	26.3%	2.1%	1382
Floridablanca	17.6%	28.1%	16.1%	36.2%	2.0%	1982
Fusagasugá	17.8%	32.4%	18.9%	29.3%	1.6%	1121
Girardot	17.3%	32.6%	21.6%	25.7%	2.9%	912
Girón	20.3%	31.0%	17.0%	30.8%	0.8%	1109
Guainía	24.6%	33.3%	21.3%	18.6%	2.2%	183
Guaviare	22.7%	32.0%	20.0%	23.5%	1.8%	621
Huila	19.7%	32.5%	21.2%	25.4%	1.2%	5194
Ibagué	19.4%	30.8%	18.8%	29.5%	1.4%	4714
Ipiales	18.7%	34.5%	19.3%	26.9%	0.6%	1066
Itagüí	18.7%	30.4%	21.9%	26.7%	2.2%	1746
Jamundí	19.4%	33.0%	21.2%	25.2%	1.2%	939
La Guajira	18.9%	31.4%	24.8%	23.1%	1.9%	2204
Lorica	20.5%	31.8%	26.2%	19.9%	1.6%	1329
Magangué	20.9%	31.4%	23.8%	22.2%	1.8%	1065
Magdalena	20.5%	32.8%	23.1%	21.2%	2.5%	5904
Maicao	19.6%	30.0%	24.4%	24.8%	1.3%	1178
Malambo	18.1%	28.5%	18.1%	33.5%	1.9%	786
Manizales	21.0%	29.7%	18.9%	28.8%	1.6%	2770
Medellín	19.8%	28.7%	20.5%	28.7%	2.3%	17124
Meta	19.6%	31.6%	21.5%	25.3%	2.1%	3789

Continúa en la siguiente página



ETC/País	A	B	C	D	Omisión y multimarca	Nº estudiantes
Montería	19.8%	30.3%	21.8%	26.2%	1.9%	4177
Mosquera	20.0%	28.5%	17.7%	32.0%	1.7%	1158
Nariño	19.8%	33.6%	20.4%	24.4%	1.8%	6043
Neiva	19.5%	29.5%	19.1%	30.0%	1.9%	2951
Norte de Santander	20.6%	32.4%	20.0%	26.0%	1.1%	5090
Palmira	18.5%	28.5%	17.2%	33.4%	2.4%	2330
Pasto	20.0%	31.6%	19.0%	27.9%	1.4%	3211
Pereira	20.4%	28.3%	19.8%	29.9%	1.6%	3748
Piedecuesta	19.4%	30.3%	18.5%	30.2%	1.7%	1186
Pitalito	19.1%	31.6%	18.4%	29.9%	1.1%	1068
Popayán	19.6%	30.0%	18.4%	29.8%	2.2%	2459
Putumayo	20.5%	30.5%	20.9%	26.2%	1.9%	2703
Quibdó	20.5%	31.1%	22.5%	20.8%	5.1%	1087
Quindío	20.4%	32.1%	22.2%	24.0%	1.3%	2038
Riohacha	19.3%	33.6%	20.4%	24.6%	2.2%	1341
Rionegro	19.0%	28.0%	20.2%	31.5%	1.4%	1086
Risaralda	20.5%	32.9%	22.4%	22.7%	1.5%	1936
Sabaneta	20.4%	27.6%	12.9%	37.7%	1.4%	496
Sahagún	18.1%	31.0%	23.9%	25.9%	1.1%	1079
San Andrés	16.6%	30.2%	22.1%	28.9%	2.1%	529
Santa Marta	20.4%	30.5%	20.4%	26.1%	2.6%	4355
Santander	17.4%	32.7%	20.1%	29.0%	0.9%	6430
Sincelejo	19.6%	32.5%	22.9%	24.1%	1.0%	2695
Soacha	19.3%	32.5%	19.7%	26.8%	1.7%	4802
Sogamoso	19.0%	31.6%	15.9%	32.8%	0.6%	1267
Soledad	19.9%	30.2%	20.7%	26.8%	2.4%	4099
Sucre	20.8%	32.7%	24.1%	21.0%	1.4%	5462
Tolima	19.3%	32.7%	22.7%	23.5%	1.8%	6959
Tuluá	18.9%	31.1%	20.4%	27.5%	2.1%	1832
Tumaco	21.4%	31.0%	25.9%	18.2%	3.5%	1334
Tunja	16.8%	30.5%	17.7%	33.5%	1.4%	1740
Turbo	19.3%	33.0%	26.6%	19.0%	2.2%	1254
Uribe	23.5%	36.8%	22.8%	14.7%	2.3%	307
Valle del Cauca	20.2%	31.4%	21.9%	24.7%	1.7%	6250
Valledupar	20.3%	31.2%	21.1%	25.8%	1.5%	4092
Vichada	18.3%	30.9%	21.8%	24.8%	4.2%	404
Villavicencio	18.9%	28.7%	18.5%	32.5%	1.5%	4110
Yopal	18.0%	30.8%	20.3%	29.7%	1.2%	1395
Yumbo	22.8%	27.6%	19.7%	27.2%	2.7%	894
Zipaquirá	17.8%	29.8%	16.8%	34.5%	1.0%	1155
Colombia	19.2%	30.6%	20.6%	27.8%	1.9%	381883

*Es posible que los porcentajes mostrados no sumen exactamente 100 debido a aproximaciones decimales.

• **Pregunta 19.**

La gráfica representa la cantidad de galones de gasolina que tiene el tanque de un automóvil, cuando se desplaza entre dos ciudades.

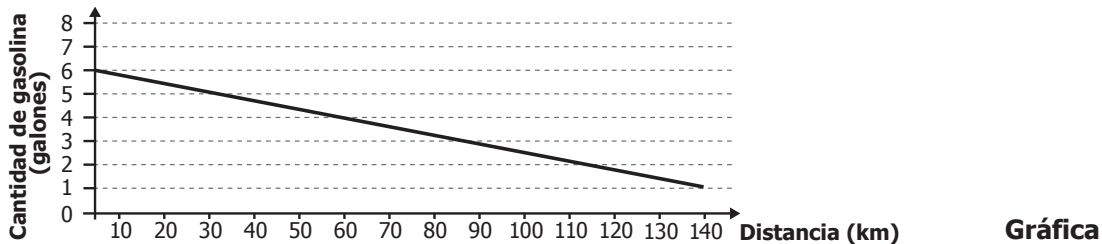

El conductor afirma que el automóvil consumió en total 4 galones de gasolina en este desplazamiento. Esta afirmación es

- A. falsa, porque consumió 5 galones en total.
- B. falsa, porque consumió 1 galón en total.
- C. verdadera, porque inició su recorrido con 4 galones y terminó sin gasolina.
- D. verdadera, porque inició su recorrido con 5 galones y terminó con 1 galón.

• **Estructura**

Competencia	Razonamiento
Componente	Numérico - variacional
Afirmación	Interpretar tendencias que se presentan en una situación de variación.
Nivel de desempeño	Satisfactorio
Respuesta Correcta	A

• **Resultados a nivel nacional y de Entidad Territorial Certificada (ETC)**

ETC/País	A	B	C	D	Omisión y multimarca	N° estudiantes
Amazonas	23.9%	12.3%	25.8%	32.1%	5.9%	627
Antioquia	33.1%	13.6%	19.9%	30.8%	2.5%	19243
Apartadó	30.1%	16.8%	25.6%	26.2%	1.3%	1088
Arauca	31.6%	11.5%	21.9%	33.8%	1.1%	1581
Armenia	38.3%	12.9%	18.6%	29.2%	1.1%	2587
Atlántico	30.9%	14.5%	21.1%	30.7%	2.7%	4931
Barrancabermeja	36.7%	13.2%	19.5%	28.6%	2.0%	1845
Barranquilla	37.6%	13.3%	18.3%	28.9%	1.9%	10591
Bello	38.2%	13.2%	17.6%	28.8%	2.2%	3032
Bogotá, D.C.	43.5%	11.4%	15.3%	27.9%	1.9%	62070
Bolívar	24.8%	15.8%	25.2%	31.4%	2.7%	7542
Boyacá	38.4%	11.8%	18.3%	30.2%	1.3%	7836
Bucaramanga	47.2%	11.1%	14.6%	25.2%	1.9%	4498
Buenaventura	26.3%	14.4%	24.0%	32.6%	2.6%	2785
Buga	35.7%	12.8%	17.2%	32.6%	1.7%	917
Caldas	32.5%	12.8%	20.8%	32.6%	1.4%	4430
Cali	38.4%	12.8%	17.9%	28.8%	2.2%	16580
Caquetá	28.5%	15.0%	23.5%	30.8%	2.1%	1658
Cartagena	32.4%	14.9%	21.5%	29.1%	2.1%	9657
Cartago	37.7%	12.9%	17.3%	29.5%	2.7%	1017
Casanare	34.2%	12.0%	19.1%	33.2%	1.6%	2177
Cauca	28.4%	12.2%	22.4%	34.6%	2.5%	8223
Cesar	30.8%	14.1%	21.6%	32.5%	1.0%	5409
Chocó	23.7%	14.0%	26.4%	33.4%	2.6%	2050
Chía	52.0%	9.3%	10.5%	26.7%	1.5%	1416
Ciénaga	25.9%	14.8%	26.5%	30.7%	2.1%	1059
Cundinamarca	40.0%	11.4%	17.0%	29.9%	1.8%	13371
Córdoba	26.3%	14.2%	23.4%	34.1%	2.1%	8943
Cúcuta	39.1%	12.6%	17.7%	29.2%	1.4%	5733
Dosquebradas	40.4%	11.7%	17.7%	29.0%	1.2%	1319
Duitama	53.0%	9.4%	10.6%	26.1%	0.9%	1251
Envigado	50.2%	11.5%	14.1%	22.8%	1.4%	1633
Facatativá	43.8%	10.2%	12.7%	31.9%	1.3%	1114
Florencia	35.6%	12.4%	18.5%	31.3%	2.1%	1382
Floridablanca	50.0%	10.8%	13.3%	23.8%	2.1%	1982
Fusagasugá	39.7%	12.5%	18.3%	27.6%	2.0%	1121
Girardot	31.1%	13.5%	21.1%	31.3%	3.1%	912

Continúa en la siguiente página

SABER 9 - MATEMÁTICAS

ETC/País	A	B	C	D	Omisión y multimarca	N° estudiantes
Girón	41.4%	11.5%	15.6%	31.1%	0.5%	1109
Guainía	33.3%	8.7%	23.0%	32.2%	2.7%	183
Guaviare	30.9%	12.2%	19.5%	35.7%	1.6%	621
Huila	32.3%	12.1%	19.1%	35.2%	1.3%	5194
Ibagué	38.6%	12.8%	17.5%	29.8%	1.2%	4714
Ipiales	39.0%	13.8%	16.1%	30.6%	0.5%	1066
Itagüí	37.4%	15.0%	17.3%	28.2%	2.1%	1746
Jamundí	33.7%	13.2%	18.6%	32.5%	2.0%	939
La Guajira	27.5%	15.9%	23.3%	31.6%	1.7%	2204
Lorica	25.9%	16.6%	23.0%	33.0%	1.4%	1329
Magangué	29.7%	12.8%	20.8%	34.4%	2.4%	1065
Magdalena	25.2%	15.3%	24.3%	32.7%	2.5%	5904
Maicao	28.2%	12.6%	24.9%	32.7%	1.7%	1178
Malambo	32.6%	15.3%	20.9%	29.1%	2.2%	786
Manizales	39.9%	12.4%	17.5%	28.6%	1.7%	2770
Medellín	38.1%	13.2%	18.2%	28.3%	2.3%	17124
Meta	32.9%	13.4%	19.6%	31.6%	2.4%	3789
Montería	32.7%	12.7%	21.2%	31.3%	2.2%	4177
Mosquera	46.3%	10.8%	13.1%	27.8%	2.0%	1158
Nariño	35.7%	12.5%	19.3%	30.6%	1.9%	6043
Neiva	39.5%	11.3%	17.3%	30.1%	1.8%	2951
Norte de Santander	36.2%	12.5%	18.6%	31.4%	1.2%	5090
Palmira	39.9%	10.4%	16.2%	30.9%	2.6%	2330
Pasto	42.9%	10.8%	15.4%	29.6%	1.2%	3211
Pereira	40.6%	12.5%	17.4%	27.8%	1.7%	3748
Piedecuesta	39.5%	12.6%	14.9%	31.3%	1.7%	1186
Pitalito	39.8%	11.6%	15.6%	31.7%	1.2%	1068
Popayán	40.1%	12.6%	14.7%	30.3%	2.3%	2459
Putumayo	31.8%	11.8%	20.3%	33.9%	2.1%	2703
Quibdó	25.3%	15.1%	24.2%	30.9%	4.5%	1087
Quindío	33.3%	13.4%	19.6%	31.6%	2.1%	2038
Riohacha	32.4%	14.2%	20.7%	30.1%	2.6%	1341
Rionegro	40.5%	12.6%	17.1%	28.6%	1.1%	1086
Risaralda	30.6%	14.5%	19.0%	34.0%	1.9%	1936
Sabaneta	46.6%	13.1%	13.9%	24.6%	1.8%	496
Sahagún	33.4%	12.5%	21.4%	31.6%	1.1%	1079
San Andrés	31.9%	16.6%	21.4%	28.7%	1.3%	529
Santa Marta	34.6%	13.0%	20.9%	29.0%	2.5%	4355
Santander	41.8%	11.2%	15.5%	30.3%	1.2%	6430

Continúa en la siguiente página



ETC/País	A	B	C	D	Omisión y multimarca	N° estudiantes
Sincelejo	30.5%	15.5%	21.4%	31.1%	1.5%	2695
Soacha	37.4%	12.3%	18.3%	30.1%	1.9%	4802
Sogamoso	47.7%	10.5%	12.5%	28.7%	0.7%	1267
Soledad	34.5%	14.6%	18.4%	30.2%	2.2%	4099
Sucre	25.5%	14.2%	24.4%	34.5%	1.4%	5462
Tolima	30.6%	13.0%	20.5%	34.1%	1.8%	6959
Tuluá	39.5%	11.9%	16.0%	30.5%	2.1%	1832
Tumaco	20.8%	13.3%	29.2%	33.1%	3.6%	1334
Tunja	46.9%	11.7%	14.9%	25.1%	1.4%	1740
Turbo	24.1%	13.1%	24.6%	35.6%	2.6%	1254
Uribe	15.6%	16.0%	27.0%	39.7%	1.6%	307
Valle del Cauca	33.3%	13.4%	18.8%	32.6%	1.8%	6250
Valledupar	34.1%	12.3%	20.6%	31.2%	1.7%	4092
Vichada	26.0%	13.9%	21.8%	33.4%	5.0%	404
Villavicencio	39.9%	12.7%	17.7%	28.2%	1.5%	4110
Yopal	40.9%	12.2%	14.8%	30.8%	1.3%	1395
Yumbo	36.6%	11.7%	17.6%	32.0%	2.1%	894
Zipaquirá	46.7%	9.4%	16.5%	25.8%	1.6%	1155
Colombia	36.5%	12.7%	18.7%	30.1%	1.9%	381883

*Es posible que los porcentajes mostrados no sumen exactamente 100 debido a aproximaciones decimales.

• **Pregunta 20.**

Los 400 estudiantes de un colegio se clasificaron en cinco grupos, de acuerdo con su edad en años, así: 0 a 10, 11 a 13, 14 a 16, 17 a 19 y 20 a 22.

Se sabe que la probabilidad de seleccionar al azar un estudiante del colegio con edades entre 11 y 16 años es del 60%.

¿Cuál de las siguientes tablas puede representar correctamente la clasificación y distribución de los estudiantes del colegio?

A.

Edad (años)	0 a 10	11 a 13	14 a 16	17 a 19	20 a 22
Número de estudiantes	110	90	70	105	25

B.

Edad (años)	0 a 10	11 a 13	14 a 16	17 a 19	20 a 22
Número de estudiantes	120	60	60	130	30

C.

Edad (años)	0 a 10	11 a 13	14 a 16	17 a 19	20 a 22
Número de estudiantes	50	100	140	70	40

D.

Edad (años)	0 a 10	11 a 13	14 a 16	17 a 19	20 a 22
Número de estudiantes	145	35	45	75	100

• **Estructura**

Competencia	Razonamiento
Componente	Aleatorio
Afirmación	Establecer conjeturas y verificar hipótesis acerca de los resultados de un experimento aleatorio usando conceptos básicos de probabilidad.
Nivel de desempeño	Avanzado
Respuesta Correcta	C

• **Resultados a nivel nacional y de Entidad Territorial Certificada (ETC)**

ETC/País	A	B	C	D	Omisión y multimarca	N° estudiantes
Amazonas	15.3%	29.8%	31.4%	18.3%	5.1%	627
Antioquia	18.0%	28.4%	35.7%	15.4%	2.6%	19243
Apartadó	18.9%	27.2%	37.0%	15.3%	1.5%	1088
Arauca	15.7%	29.9%	39.1%	14.0%	1.3%	1581
Armenia	17.4%	24.9%	41.4%	15.2%	1.1%	2587
Atlántico	19.2%	27.3%	34.6%	16.3%	2.6%	4931
Barrancabermeja	17.1%	26.4%	39.9%	14.6%	2.0%	1845
Barranquilla	17.2%	28.6%	38.5%	13.8%	1.9%	10591
Bello	17.1%	26.8%	40.1%	13.8%	2.3%	3032
Bogotá, D.C.	15.8%	27.3%	43.7%	11.4%	1.9%	62070
Bolívar	19.2%	29.0%	32.1%	16.9%	2.8%	7542
Boyacá	16.1%	28.6%	40.4%	13.8%	1.2%	7836
Bucaramanga	14.5%	27.5%	44.0%	12.0%	2.0%	4498
Buenaventura	18.8%	30.5%	32.7%	15.8%	2.3%	2785
Buga	19.3%	28.7%	36.1%	13.7%	2.2%	917
Caldas	17.4%	30.5%	36.9%	14.2%	1.1%	4430
Cali	16.9%	28.6%	39.1%	13.0%	2.4%	16580
Caquetá	17.0%	30.6%	34.8%	15.3%	2.3%	1658
Cartagena	19.4%	28.9%	35.1%	14.5%	2.1%	9657
Cartago	16.6%	29.0%	37.2%	14.7%	2.6%	1017
Casanare	17.2%	30.8%	36.2%	13.9%	2.0%	2177
Cauca	18.7%	32.0%	31.3%	15.7%	2.3%	8223
Cesar	19.5%	27.8%	35.8%	15.8%	1.2%	5409
Chocó	18.7%	31.1%	29.5%	18.2%	2.5%	2050
Chía	14.9%	23.2%	48.7%	11.6%	1.7%	1416
Ciénaga	21.2%	29.4%	28.6%	18.7%	2.2%	1059
Cundinamarca	15.6%	28.8%	41.8%	12.2%	1.6%	13371
Córdoba	18.9%	28.9%	32.5%	17.8%	1.9%	8943
Cúcuta	16.3%	28.9%	41.0%	12.6%	1.2%	5733
Dosquebradas	16.7%	29.6%	39.3%	13.0%	1.4%	1319
Duitama	13.4%	27.6%	48.4%	9.6%	1.0%	1251
Envigado	13.8%	26.1%	48.6%	10.2%	1.3%	1633
Facatativá	14.9%	30.8%	41.5%	11.8%	1.1%	1114
Florencia	17.8%	27.6%	40.3%	12.3%	2.0%	1382
Floridablanca	13.8%	27.0%	46.6%	10.6%	2.0%	1982
Fusagasugá	15.0%	29.1%	41.9%	12.5%	1.5%	1121
Girardot	18.9%	29.4%	35.4%	13.9%	2.4%	912

Continúa en la siguiente página

SABER 9 - MATEMÁTICAS

ETC/País	A	B	C	D	Omisión y multimarca	N° estudiantes
Girón	18.8%	28.3%	40.1%	12.1%	0.6%	1109
Guainía	14.2%	36.1%	35.5%	13.7%	0.5%	183
Guaviare	18.0%	31.9%	35.9%	13.0%	1.1%	621
Huila	17.0%	31.2%	36.2%	14.3%	1.3%	5194
Ibagué	16.5%	27.6%	39.9%	14.7%	1.4%	4714
Ipiales	16.6%	34.4%	36.4%	12.0%	0.6%	1066
Itagüí	18.4%	25.1%	39.1%	14.7%	2.7%	1746
Jamundí	18.3%	30.9%	36.0%	13.4%	1.4%	939
La Guajira	20.5%	29.0%	32.4%	16.7%	1.5%	2204
Lorica	19.8%	29.2%	30.4%	19.3%	1.3%	1329
Magangué	18.5%	30.2%	32.9%	16.5%	1.9%	1065
Magdalena	19.0%	29.4%	31.5%	18.1%	2.0%	5904
Maicao	20.4%	28.2%	34.0%	16.2%	1.2%	1178
Malambo	17.8%	26.3%	36.8%	16.9%	2.2%	786
Manizales	16.3%	30.0%	38.3%	13.6%	1.8%	2770
Medellín	18.1%	26.3%	38.5%	14.7%	2.4%	17124
Meta	18.5%	29.0%	37.2%	13.2%	2.0%	3789
Montería	19.4%	27.8%	36.1%	15.0%	1.8%	4177
Mosquera	16.3%	25.5%	45.0%	11.4%	1.8%	1158
Nariño	16.9%	30.7%	36.0%	14.8%	1.6%	6043
Neiva	17.3%	29.3%	40.0%	11.5%	1.9%	2951
Norte de Santander	17.5%	30.7%	36.9%	13.9%	1.1%	5090
Palmira	16.4%	30.4%	39.0%	11.7%	2.6%	2330
Pasto	15.0%	30.6%	41.0%	11.9%	1.4%	3211
Pereira	15.5%	28.0%	41.6%	13.1%	1.7%	3748
Piedecuesta	16.7%	26.1%	42.3%	12.9%	1.9%	1186
Pitalito	16.7%	28.3%	41.7%	12.5%	0.9%	1068
Popayán	15.4%	29.1%	41.0%	12.0%	2.5%	2459
Putumayo	16.1%	32.0%	36.1%	14.0%	1.8%	2703
Quibdó	20.7%	26.2%	31.1%	17.2%	4.8%	1087
Quindío	18.2%	27.4%	34.6%	18.4%	1.4%	2038
Riohacha	15.4%	28.9%	35.8%	18.0%	1.9%	1341
Rionegro	15.2%	27.7%	42.1%	13.7%	1.3%	1086
Risaralda	18.4%	28.0%	36.2%	15.2%	2.1%	1936
Sabaneta	16.1%	26.4%	44.0%	11.9%	1.6%	496
Sahagún	17.1%	29.0%	34.9%	17.9%	1.0%	1079
San Andrés	21.0%	28.0%	35.2%	14.0%	1.9%	529
Santa Marta	16.7%	29.1%	36.5%	15.4%	2.3%	4355
Santander	16.1%	28.5%	41.8%	12.4%	1.2%	6430

Continúa en la siguiente página



ETC/País	A	B	C	D	Omisión y multimarca	N° estudiantes
Sincelejo	20.3%	28.6%	33.3%	16.3%	1.4%	2695
Soacha	16.2%	29.8%	39.9%	12.3%	1.8%	4802
Sogamoso	15.2%	28.6%	45.2%	9.9%	1.1%	1267
Soledad	18.1%	28.0%	37.2%	14.4%	2.3%	4099
Sucre	20.2%	29.0%	31.9%	17.6%	1.3%	5462
Tolima	17.2%	29.4%	35.7%	16.1%	1.6%	6959
Tuluá	15.1%	31.2%	38.2%	13.4%	2.1%	1832
Tumaco	16.0%	32.5%	29.7%	18.7%	3.1%	1334
Tunja	13.9%	28.4%	45.1%	11.1%	1.5%	1740
Turbo	19.5%	27.8%	30.9%	19.5%	2.2%	1254
Uribe	21.8%	26.1%	30.9%	18.2%	2.9%	307
Valle del Cauca	17.9%	30.0%	35.8%	14.6%	1.7%	6250
Valledupar	17.3%	29.5%	36.6%	15.0%	1.6%	4092
Vichada	19.3%	29.0%	32.4%	14.9%	4.5%	404
Villavicencio	15.8%	27.8%	43.2%	11.7%	1.6%	4110
Yopal	15.6%	25.0%	46.1%	12.0%	1.2%	1395
Yumbo	17.8%	28.2%	36.9%	15.0%	2.1%	894
Zipaquirá	13.8%	29.5%	43.3%	11.9%	1.5%	1155
Colombia	17.2%	28.5%	38.5%	13.9%	1.9%	381883

*Es posible que los porcentajes mostrados no sumen exactamente 100 debido a aproximaciones decimales.

• **Pregunta 21.**

Angélica y Laura son jugadoras destacadas de tenis de mesa.

La tabla registra los partidos ganados y perdidos por cada una, en los últimos 20 enfrentamientos entre ellas.

Jugadora	Partido																			
	1	2	3	4	5	6	7	8	9	10	11	12	13	14	15	16	17	18	19	20
Angélica	P	G	G	G	P	G	G	P	G	P	G	G	G	G	G	P	G	G	G	G
Laura	G	P	P	P	G	P	P	G	P	G	P	P	P	P	P	G	P	P	P	P

P: partido perdido.

G: partido ganado.

Tabla

Según los resultados presentados en los 20 partidos, la probabilidad que tuvo Laura de ganar fue

- A. la tercera parte de la probabilidad que tuvo Angélica de ganar.
- B. la mitad de la probabilidad que tuvo Angélica de ganar.
- C. igual a la probabilidad que tuvo Angélica de ganar.
- D. tres veces la probabilidad que tuvo Angélica de ganar.

• **Estructura**

Competencia	Razonamiento
Componente	Aleatorio
Afirmación	Utilizar diferentes métodos y estrategias para calcular la probabilidad de eventos simples.
Nivel de desempeño	Satisfactorio
Respuesta Correcta	A

• Resultados a nivel nacional y de Entidad Territorial Certificada (ETC)

ETC/País	A	B	C	D	Omisión y multimarca	N° estudiantes
Amazonas	42.3%	19.5%	13.7%	22.8%	1.8%	627
Antioquia	50.4%	14.2%	13.4%	20.6%	1.4%	19242
Apartadó	52.3%	13.6%	14.2%	18.8%	1.0%	1088
Arauca	50.8%	13.2%	12.0%	23.7%	0.3%	1581
Armenia	56.6%	14.0%	11.2%	17.7%	0.5%	2587
Atlántico	48.3%	16.5%	13.4%	20.9%	0.8%	4931
Barrancabermeja	54.5%	13.0%	11.9%	19.9%	0.7%	1845
Barranquilla	56.8%	12.6%	11.2%	18.6%	0.7%	10592
Bello	56.9%	13.1%	12.1%	16.7%	1.2%	3031
Bogotá, D.C.	60.6%	10.4%	10.6%	17.9%	0.6%	62071
Bolívar	45.2%	17.2%	13.7%	22.8%	1.1%	7541
Boyacá	55.4%	11.8%	11.0%	21.5%	0.3%	7838
Bucaramanga	61.8%	8.5%	11.1%	17.9%	0.6%	4497
Buenaventura	45.7%	15.8%	15.0%	22.4%	1.1%	2787
Buga	53.8%	12.9%	10.4%	22.5%	0.5%	917
Caldas	51.2%	15.4%	12.8%	20.2%	0.4%	4429
Cali	56.3%	13.1%	11.4%	18.4%	0.8%	16580
Caquetá	47.2%	15.9%	13.3%	23.1%	0.4%	1657
Cartagena	52.6%	14.8%	12.6%	19.1%	0.9%	9659
Cartago	54.7%	12.5%	12.9%	19.5%	0.5%	1017
Casanare	51.2%	13.5%	10.7%	24.1%	0.6%	2177
Cauca	44.8%	16.1%	13.9%	24.2%	0.9%	8222
Cesar	47.9%	15.3%	14.8%	21.7%	0.3%	5409
Chocó	39.7%	17.2%	16.1%	26.0%	1.0%	2051
Chía	60.9%	10.4%	11.1%	16.9%	0.7%	1416
Ciénaga	42.8%	19.1%	14.4%	22.7%	0.9%	1060
Cundinamarca	55.6%	12.2%	10.6%	21.1%	0.6%	13372
Córdoba	45.7%	17.2%	14.2%	22.1%	0.8%	8943
Cúcuta	57.3%	11.8%	11.1%	18.9%	0.8%	5733
Dosquebradas	57.8%	12.4%	9.5%	19.6%	0.7%	1319
Duitama	63.4%	8.3%	10.1%	18.0%	0.2%	1251
Envigado	64.9%	8.8%	13.0%	12.7%	0.5%	1633
Facatativá	57.1%	8.8%	11.1%	22.7%	0.3%	1113
Florencia	49.5%	14.1%	13.4%	22.3%	0.7%	1383
Floridablanca	62.3%	9.2%	9.7%	17.9%	0.8%	1982
Fusagasugá	59.6%	10.1%	10.6%	18.9%	0.8%	1119
Girardot	50.1%	14.8%	13.4%	20.9%	0.8%	912

Continúa en la siguiente página

SABER 9 - MATEMÁTICAS

ETC/País	A	B	C	D	Omisión y multimarca	N° estudiantes
Girón	57.5%	11.6%	11.6%	19.0%	0.2%	1109
Guainía	47.0%	15.8%	15.3%	21.3%	0.5%	183
Guaviare	49.1%	13.8%	11.8%	24.3%	1.0%	621
Huila	51.2%	14.6%	11.2%	22.5%	0.5%	5192
Ibagué	56.4%	12.0%	11.3%	19.8%	0.4%	4714
Ipiales	54.8%	11.4%	11.4%	21.9%	0.7%	1066
Itagüí	58.6%	13.3%	12.2%	14.6%	1.3%	1746
Jamundí	49.4%	13.7%	14.2%	22.5%	0.2%	939
La Guajira	44.8%	17.4%	14.6%	22.6%	0.6%	2203
Lorica	45.0%	17.4%	14.4%	22.9%	0.3%	1329
Magangué	48.7%	16.9%	12.3%	21.0%	1.0%	1065
Magdalena	44.1%	17.9%	14.4%	22.5%	1.1%	5904
Maicao	47.0%	16.0%	12.9%	23.8%	0.3%	1178
Malambo	52.9%	16.0%	10.8%	19.7%	0.6%	787
Manizales	57.5%	13.3%	10.8%	17.8%	0.6%	2771
Medellín	56.9%	12.8%	12.3%	16.8%	1.2%	17124
Meta	52.5%	12.8%	11.5%	22.3%	0.8%	3790
Montería	53.4%	13.9%	13.2%	18.6%	0.9%	4178
Mosquera	62.8%	7.7%	9.8%	19.3%	0.5%	1158
Nariño	51.0%	12.2%	12.2%	23.8%	0.8%	6043
Neiva	57.2%	12.6%	10.0%	19.7%	0.5%	2950
Norte de Santander	52.9%	12.8%	10.8%	23.0%	0.5%	5090
Palmira	55.2%	12.6%	10.1%	21.6%	0.6%	2329
Pasto	59.3%	10.9%	11.3%	17.8%	0.7%	3212
Pereira	56.4%	11.6%	11.8%	19.9%	0.4%	3749
Piedecuesta	58.4%	9.7%	13.8%	17.1%	0.9%	1186
Pitalito	57.0%	11.5%	9.8%	21.0%	0.7%	1067
Popayán	58.0%	10.7%	11.3%	19.3%	0.8%	2459
Putumayo	50.7%	13.9%	11.5%	22.9%	1.0%	2701
Quibdó	42.1%	16.9%	16.0%	22.6%	2.4%	1086
Quindío	51.8%	15.3%	12.8%	19.7%	0.4%	2039
Riohacha	51.3%	11.6%	14.0%	22.1%	1.0%	1341
Rionegro	56.2%	13.0%	11.3%	18.9%	0.6%	1086
Risaralda	52.5%	15.2%	12.0%	20.0%	0.3%	1936
Sabaneta	59.1%	8.7%	13.1%	18.1%	1.0%	496
Sahagún	51.3%	14.4%	12.2%	21.6%	0.6%	1079
San Andrés	52.0%	17.0%	14.6%	16.1%	0.4%	529
Santa Marta	49.2%	16.1%	13.2%	20.5%	1.0%	4355
Santander	55.7%	11.2%	11.5%	21.1%	0.4%	6431

Continúa en la siguiente página



ETC/País	A	B	C	D	Omisión y multimarca	N° estudiantes
Sincelejo	52.3%	14.7%	14.1%	18.4%	0.4%	2696
Soacha	55.7%	12.7%	10.8%	19.7%	1.0%	4802
Sogamoso	60.0%	9.5%	11.0%	19.2%	0.4%	1267
Soledad	54.0%	12.7%	11.5%	20.7%	1.0%	4098
Sucre	44.8%	16.4%	15.1%	23.1%	0.5%	5462
Tolima	49.1%	14.8%	12.5%	23.1%	0.6%	6958
Tuluá	52.7%	14.2%	11.1%	21.5%	0.4%	1832
Tumaco	42.4%	16.3%	15.2%	25.4%	0.6%	1334
Tunja	62.4%	10.0%	10.6%	16.8%	0.2%	1740
Turbo	44.9%	15.5%	14.6%	24.3%	0.7%	1254
Uribe	37.9%	19.9%	13.7%	27.8%	0.7%	306
Valle del Cauca	50.6%	14.9%	12.9%	21.0%	0.5%	6252
Valledupar	51.1%	14.4%	13.3%	20.6%	0.7%	4092
Vichada	42.3%	17.1%	14.4%	26.0%	0.2%	404
Villavicencio	56.2%	11.2%	11.1%	21.1%	0.5%	4110
Yopal	57.1%	11.2%	10.8%	20.3%	0.6%	1395
Yumbo	55.6%	13.2%	10.4%	19.8%	1.0%	894
Zipaquirá	59.8%	10.2%	10.4%	18.8%	0.8%	1155
Colombia	54.0%	13.1%	12.0%	20.1%	0.7%	381884

*Es posible que los porcentajes mostrados no sumen exactamente 100 debido a aproximaciones decimales.

• **Pregunta 22.**

Una empresa que produce barras de chocolate empaca su producto en cajas como la que se muestra en la figura.

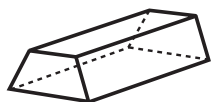

Figura

¿Con cuál de los siguientes moldes se puede armar la caja?

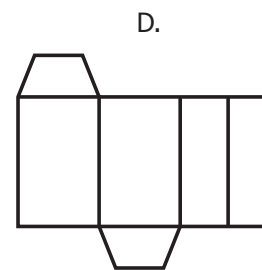
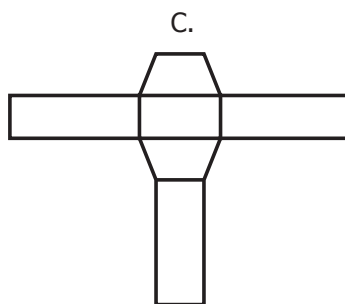
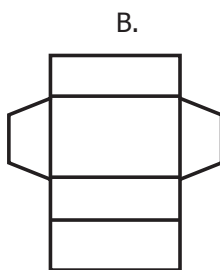
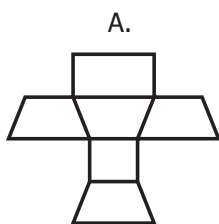

• **Estructura**

Competencia	Razonamiento
Componente	Espacial - métrico
Afirmación	Argumentar formal e informalmente sobre propiedades y relaciones de figuras planas y sólidos.
Nivel de desempeño	Mínimo
Respuesta Correcta	B

• Resultados a nivel nacional y de Entidad Territorial Certificada (ETC)

ETC/País	A	B	C	D	Omisión y multimarca	N° estudiantes
Amazonas	5.6%	77.5%	5.7%	9.6%	1.6%	627
Antioquia	8.4%	70.4%	7.6%	12.1%	1.4%	19242
Apartadó	9.8%	69.8%	8.4%	10.9%	1.1%	1088
Arauca	6.5%	74.4%	6.8%	11.7%	0.6%	1581
Armenia	5.9%	73.6%	8.2%	11.6%	0.6%	2587
Atlántico	9.3%	68.9%	7.3%	13.5%	1.0%	4931
Barrancabermeja	6.3%	73.0%	7.6%	12.5%	0.5%	1845
Barranquilla	6.2%	73.7%	7.3%	12.1%	0.7%	10592
Bello	6.6%	72.7%	8.0%	11.6%	1.1%	3031
Bogotá, D.C.	4.6%	78.8%	5.6%	10.4%	0.5%	62071
Bolívar	11.4%	64.5%	9.3%	13.4%	1.4%	7541
Boyacá	5.7%	76.4%	6.4%	11.1%	0.4%	7838
Bucaramanga	4.2%	78.3%	5.5%	11.4%	0.6%	4497
Buenaventura	10.3%	67.2%	8.1%	13.0%	1.4%	2787
Buga	6.0%	75.5%	7.0%	11.5%	0.1%	917
Caldas	8.6%	71.2%	7.7%	12.1%	0.4%	4429
Cali	5.6%	74.2%	7.4%	12.1%	0.8%	16580
Caquetá	8.3%	73.0%	6.5%	11.6%	0.7%	1657
Cartagena	8.4%	68.8%	8.7%	13.0%	1.1%	9659
Cartago	5.4%	74.2%	7.7%	12.5%	0.2%	1017
Casanare	6.4%	76.3%	6.5%	10.4%	0.4%	2177
Cauca	7.3%	72.1%	6.7%	13.2%	0.8%	8222
Cesar	9.8%	68.4%	8.6%	12.5%	0.7%	5409
Chocó	11.5%	66.9%	8.8%	11.1%	1.7%	2051
Chía	3.7%	82.5%	3.1%	10.3%	0.4%	1416
Ciénaga	11.1%	67.0%	6.7%	14.5%	0.7%	1060
Cundinamarca	5.6%	77.2%	5.8%	11.0%	0.5%	13372
Córdoba	10.6%	65.4%	8.5%	14.5%	1.0%	8943
Cúcuta	5.4%	76.1%	6.5%	11.3%	0.7%	5733
Dosquebradas	4.9%	74.7%	7.5%	12.1%	0.8%	1319
Duitama	3.0%	83.9%	4.1%	8.9%	0.1%	1251
Envigado	3.9%	79.9%	5.7%	10.2%	0.3%	1633
Facatativá	3.5%	81.2%	4.9%	10.1%	0.4%	1113
Florencia	5.4%	75.3%	6.4%	12.1%	0.9%	1383
Floridablanca	3.9%	77.8%	5.9%	11.6%	0.9%	1982
Fusagasugá	5.3%	76.3%	5.9%	11.7%	0.8%	1119
Girardot	9.4%	72.0%	7.0%	11.0%	0.5%	912

Continúa en la siguiente página

SABER 9 - MATEMÁTICAS

ETC/País	A	B	C	D	Omisión y multimarca	N° estudiantes
Girón	5.4%	76.1%	6.2%	11.9%	0.4%	1109
Guainía	4.4%	79.2%	4.9%	10.4%	1.1%	183
Guaviare	7.2%	75.4%	5.5%	11.1%	0.8%	621
Huila	6.9%	76.2%	5.8%	10.7%	0.4%	5192
Ibagué	5.7%	75.5%	6.4%	12.0%	0.4%	4714
Ipiales	6.7%	77.7%	6.7%	8.6%	0.4%	1066
Itagüí	6.4%	68.7%	10.6%	13.0%	1.3%	1746
Jamundí	6.7%	71.9%	7.0%	14.3%	0.1%	939
La Guajira	10.8%	68.0%	8.5%	11.4%	1.1%	2203
Lorica	11.4%	64.2%	9.3%	14.6%	0.5%	1329
Magangué	8.8%	67.9%	8.3%	13.5%	1.5%	1065
Magdalena	10.5%	66.9%	7.8%	13.5%	1.4%	5904
Maicao	8.2%	68.8%	8.0%	14.7%	0.3%	1178
Malambo	6.0%	76.5%	6.5%	10.5%	0.5%	787
Manizales	6.4%	73.3%	6.6%	13.2%	0.6%	2771
Medellín	6.4%	72.8%	7.9%	11.6%	1.3%	17124
Meta	6.3%	75.3%	6.6%	10.8%	0.9%	3790
Montería	8.3%	69.3%	8.5%	12.9%	1.0%	4178
Mosquera	5.6%	79.8%	4.4%	9.8%	0.3%	1158
Nariño	5.4%	76.8%	6.5%	10.7%	0.6%	6043
Neiva	5.7%	76.3%	5.6%	12.2%	0.3%	2950
Norte de Santander	6.4%	75.6%	7.1%	10.4%	0.6%	5090
Palmira	4.9%	76.3%	7.4%	11.0%	0.3%	2329
Pasto	4.7%	79.5%	5.3%	9.9%	0.6%	3212
Pereira	4.3%	77.1%	6.5%	11.6%	0.4%	3749
Piedecuesta	5.0%	75.6%	7.1%	11.2%	1.1%	1186
Pitalito	5.1%	79.0%	6.3%	8.9%	0.7%	1067
Popayán	4.8%	76.0%	7.2%	11.6%	0.4%	2459
Putumayo	7.3%	76.2%	5.8%	9.8%	0.9%	2701
Quibdó	10.5%	66.5%	9.3%	11.0%	2.7%	1086
Quindío	8.0%	70.0%	8.5%	13.0%	0.5%	2039
Riohacha	8.1%	71.1%	8.0%	11.6%	1.2%	1341
Rionegro	5.7%	75.5%	8.0%	10.3%	0.5%	1086
Risaralda	7.9%	72.7%	7.2%	11.8%	0.5%	1936
Sabaneta	4.6%	78.2%	6.0%	10.1%	1.0%	496
Sahagún	10.4%	68.2%	8.7%	12.2%	0.5%	1079
San Andrés	7.2%	69.6%	8.7%	14.6%	0.0%	529
Santa Marta	7.2%	69.3%	9.2%	13.2%	1.2%	4355
Santander	6.5%	76.1%	6.4%	10.8%	0.2%	6431

Continúa en la siguiente página

ETC/País	A	B	C	D	Omisión y multimarca	N° estudiantes
Sincelejo	7.5%	71.8%	8.6%	11.6%	0.5%	2696
Soacha	5.3%	75.2%	7.4%	11.0%	1.0%	4802
Sogamoso	4.2%	82.4%	4.7%	8.4%	0.2%	1267
Soledad	7.2%	72.3%	7.6%	11.9%	0.9%	4098
Sucre	10.1%	67.4%	8.3%	13.5%	0.6%	5462
Tolima	8.2%	72.0%	6.9%	12.3%	0.6%	6958
Tuluá	5.5%	75.1%	6.7%	12.3%	0.5%	1832
Tumaco	10.0%	69.6%	7.0%	12.1%	1.3%	1334
Tunja	4.0%	81.2%	4.4%	10.3%	0.1%	1740
Turbo	13.1%	65.2%	7.5%	13.3%	1.0%	1254
Uribe	9.5%	71.2%	7.5%	10.5%	1.3%	306
Valle del Cauca	7.5%	72.3%	7.7%	12.0%	0.6%	6252
Valledupar	7.0%	71.4%	8.0%	12.9%	0.8%	4092
Vichada	7.7%	75.0%	4.5%	12.4%	0.5%	404
Villavicencio	5.6%	75.3%	7.7%	10.9%	0.5%	4110
Yopal	5.4%	77.3%	5.7%	11.5%	0.1%	1395
Yumbo	5.6%	72.9%	6.2%	14.7%	0.7%	894
Zipaquirá	3.9%	81.3%	4.7%	10.0%	0.2%	1155
Colombia	6.7%	73.9%	7.0%	11.7%	0.7%	381884

*Es posible que los porcentajes mostrados no sumen exactamente 100 debido a aproximaciones decimales.

• **Pregunta 23.**

En la gráfica se representa la distribución de los estudiantes de una escuela de natación en 4 niveles: principiante, básico, medio y alto, al iniciar el curso de vacaciones.

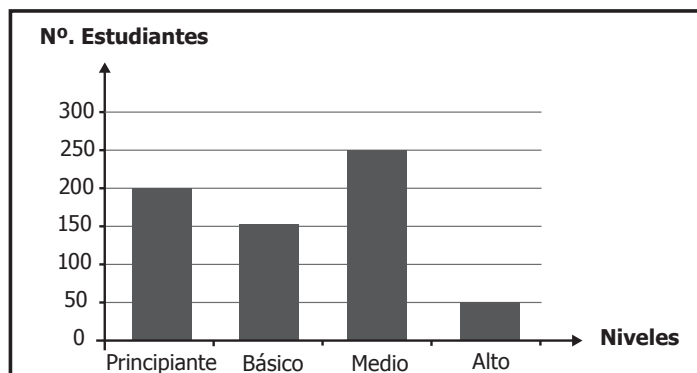

Gráfica

Transcurridas dos semanas del curso, el 30% de los estudiantes que estaban en nivel medio, es decir, 75 estudiantes, ascendió al nivel alto. ¿Cuántos estudiantes quedaron en el nivel alto?

- A. 75
- B. 80
- C. 125
- D. 175

• **Estructura**

Competencia	Resolución
Componente	Aleatorio
Afirmación	Resolver y formular problemas a partir de un conjunto de datos presentado en tablas, diagramas de barras y diagrama circular
Nivel de desempeño	Satisfactorio
Respuesta Correcta	C

• Resultados a nivel nacional y de Entidad Territorial Certificada (ETC)

ETC/País	A	B	C	D	Omisión y multimarca	Nº estudiantes
Amazonas	30.0%	10.4%	45.8%	11.5%	2.4%	627
Antioquia	21.9%	12.1%	54.8%	9.7%	1.5%	19242
Apartadó	22.4%	12.9%	53.1%	10.7%	0.9%	1088
Arauca	23.5%	12.8%	55.7%	7.5%	0.4%	1581
Armenia	19.7%	11.1%	58.9%	9.0%	1.3%	2587
Atlántico	25.9%	13.1%	49.2%	10.5%	1.3%	4931
Barrancabermeja	20.4%	12.1%	56.9%	9.6%	0.9%	1845
Barranquilla	19.5%	11.2%	59.1%	9.1%	1.0%	10592
Bello	19.5%	11.3%	59.6%	8.6%	1.0%	3031
Bogotá, D.C.	18.2%	9.5%	64.7%	6.9%	0.7%	62071
Bolívar	27.5%	13.7%	46.0%	11.2%	1.5%	7541
Boyacá	20.0%	10.1%	61.3%	8.2%	0.4%	7838
Bucaramanga	15.4%	8.6%	68.2%	7.0%	0.8%	4497
Buenaventura	28.7%	13.0%	45.0%	11.9%	1.4%	2787
Buga	21.0%	9.8%	61.3%	7.5%	0.3%	917
Caldas	22.7%	12.2%	55.4%	9.2%	0.5%	4429
Cali	19.7%	10.7%	60.2%	8.5%	0.9%	16580
Caquetá	26.1%	11.8%	52.7%	8.5%	1.0%	1657
Cartagena	22.9%	13.9%	51.6%	10.4%	1.2%	9659
Cartago	19.6%	10.8%	61.0%	8.2%	0.5%	1017
Casanare	23.0%	9.6%	58.5%	8.5%	0.5%	2177
Cauca	28.2%	11.4%	49.1%	10.3%	1.0%	8222
Cesar	26.4%	13.7%	49.1%	10.0%	0.8%	5409
Chocó	26.1%	14.0%	46.1%	12.1%	1.7%	2051
Chía	14.1%	7.1%	72.4%	5.6%	0.8%	1416
Ciénaga	29.6%	14.2%	42.5%	12.5%	1.2%	1060
Cundinamarca	20.0%	9.4%	62.7%	7.4%	0.5%	13372
Córdoba	27.1%	14.1%	47.3%	10.5%	1.1%	8943
Cúcuta	20.8%	9.7%	60.5%	8.0%	1.0%	5733
Dosquebradas	18.6%	9.9%	61.6%	9.3%	0.6%	1319
Duitama	12.1%	9.3%	72.3%	6.0%	0.3%	1251
Envigado	13.8%	8.0%	70.5%	7.2%	0.6%	1633
Facatativá	18.5%	9.6%	63.3%	7.9%	0.7%	1113
Florencia	23.2%	10.8%	57.3%	7.7%	1.0%	1383
Floridablanca	15.3%	8.7%	68.0%	7.0%	1.0%	1982
Fusagasugá	20.0%	9.3%	61.4%	8.5%	0.8%	1119
Girardot	26.0%	13.6%	51.4%	7.9%	1.1%	912

Continúa en la siguiente página

SABER 9 - MATEMÁTICAS

ETC/País	A	B	C	D	Omisión y multimarca	N° estudiantes
Girón	22.3%	9.0%	61.3%	7.0%	0.4%	1109
Guainía	32.2%	15.3%	43.7%	7.1%	1.6%	183
Guaviare	23.0%	10.5%	55.7%	9.8%	1.0%	621
Huila	23.4%	11.3%	56.9%	7.9%	0.5%	5192
Ibagué	19.3%	10.0%	61.7%	8.4%	0.6%	4714
Ipiales	18.1%	10.5%	62.4%	8.4%	0.6%	1066
Itagüí	19.8%	14.2%	54.5%	10.0%	1.5%	1746
Jamundí	22.4%	10.8%	58.0%	8.0%	0.9%	939
La Guajira	27.4%	13.6%	46.3%	11.9%	0.8%	2203
Lorica	28.3%	14.4%	43.9%	12.6%	0.7%	1329
Magangué	27.3%	14.6%	45.6%	10.9%	1.5%	1065
Magdalena	29.9%	13.3%	44.2%	11.4%	1.2%	5904
Maicao	25.8%	13.0%	50.2%	10.5%	0.5%	1178
Malambo	22.2%	13.2%	54.1%	9.7%	0.8%	787
Manizales	18.6%	9.7%	62.5%	8.5%	0.7%	2771
Medellín	18.8%	11.3%	59.4%	9.0%	1.4%	17124
Meta	22.5%	11.0%	57.4%	8.4%	0.8%	3790
Montería	22.7%	14.1%	53.2%	9.0%	1.1%	4178
Mosquera	17.5%	9.6%	65.5%	6.8%	0.5%	1158
Nariño	21.4%	10.7%	57.3%	9.8%	0.9%	6043
Neiva	20.6%	10.5%	61.4%	6.9%	0.6%	2950
Norte de Santander	21.3%	11.4%	58.1%	8.5%	0.7%	5090
Palmira	18.2%	9.9%	62.9%	8.2%	0.7%	2329
Pasto	17.6%	9.7%	64.4%	7.4%	0.9%	3212
Pereira	18.3%	9.7%	64.1%	7.6%	0.4%	3749
Piedecuesta	17.1%	8.9%	65.5%	7.4%	1.1%	1186
Pitalito	21.2%	8.3%	61.8%	7.8%	0.9%	1067
Popayán	17.5%	10.8%	62.7%	8.3%	0.7%	2459
Putumayo	23.0%	9.5%	56.8%	9.6%	1.1%	2701
Quibdó	29.6%	12.9%	43.9%	11.0%	2.7%	1086
Quindío	23.8%	13.1%	53.4%	9.0%	0.7%	2039
Riohacha	25.9%	13.9%	49.7%	9.5%	1.0%	1341
Rionegro	14.5%	8.7%	67.4%	9.1%	0.3%	1086
Risaralda	25.5%	10.3%	55.5%	7.8%	0.9%	1936
Sabaneta	13.5%	7.9%	71.8%	5.4%	1.4%	496
Sahagún	25.0%	13.1%	49.9%	11.5%	0.6%	1079
San Andrés	21.9%	16.6%	49.7%	11.0%	0.8%	529
Santa Marta	25.0%	13.2%	51.1%	9.4%	1.2%	4355
Santander	19.1%	9.6%	62.4%	8.4%	0.5%	6431

Continúa en la siguiente página



ETC/País	A	B	C	D	Omisión y multimarca	N° estudiantes
Sincelejo	22.2%	13.1%	54.7%	9.6%	0.4%	2696
Soacha	21.5%	11.4%	58.5%	7.5%	1.1%	4802
Sogamoso	16.1%	8.2%	68.0%	7.6%	0.2%	1267
Soledad	21.9%	12.6%	54.9%	9.3%	1.3%	4098
Sucre	25.8%	14.3%	48.0%	11.2%	0.7%	5462
Tolima	26.1%	11.1%	52.3%	9.7%	0.7%	6958
Tuluá	21.3%	12.0%	58.7%	7.7%	0.4%	1832
Tumaco	30.2%	13.3%	43.3%	12.2%	1.0%	1334
Tunja	16.3%	8.5%	69.8%	5.3%	0.1%	1740
Turbo	29.3%	13.2%	45.5%	10.6%	1.4%	1254
Uribe	34.0%	12.7%	42.5%	10.1%	0.7%	306
Valle del Cauca	23.3%	11.8%	55.2%	9.0%	0.7%	6252
Valledupar	26.3%	12.1%	52.2%	8.7%	0.8%	4092
Vichada	30.2%	8.9%	47.5%	12.6%	0.7%	404
Villavicencio	18.9%	10.2%	62.9%	7.5%	0.5%	4110
Yopal	18.3%	10.9%	63.8%	6.4%	0.6%	1395
Yumbo	21.4%	11.6%	57.0%	8.9%	1.0%	894
Zipaquirá	17.1%	8.5%	69.4%	4.6%	0.5%	1155
Colombia	21.5%	11.2%	57.8%	8.7%	0.9%	381884

*Es posible que los porcentajes mostrados no sumen exactamente 100 debido a aproximaciones decimales.

• **Pregunta 24.**

La figura muestra la longitud inicial de un resorte (en cm), y la que alcanza este resorte cuando sostiene bloques de distintas masas (en g).

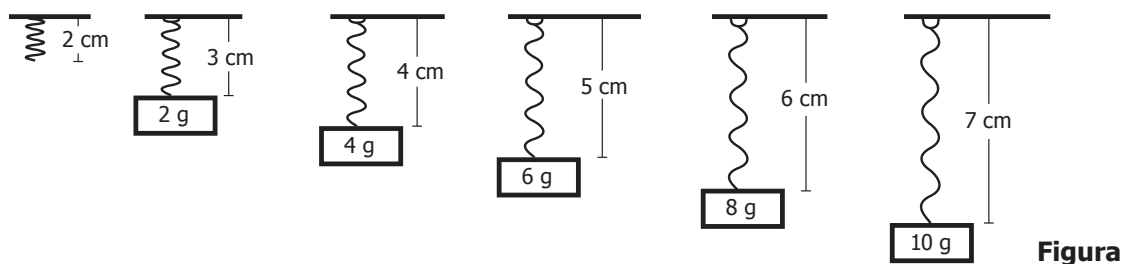

¿Cuál de las siguientes gráficas representa correctamente la relación entre la masa del bloque y la longitud del resorte?

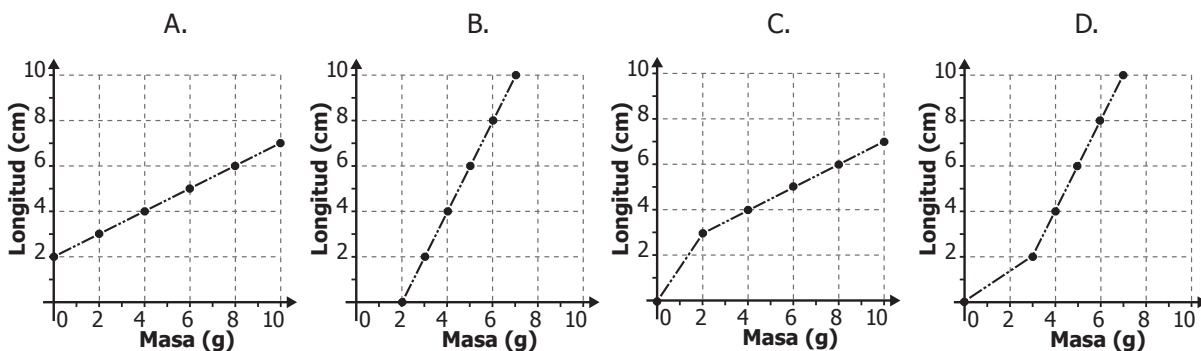

• **Estructura**

Competencia	Comunicación
Componente	Espacial - métrico
Afirmación	Usar y relacionar diferentes representaciones para modelar situaciones de variación.
Nivel de desempeño	Satisfactorio
Respuesta Correcta	A

• **Resultados a nivel nacional y de Entidad Territorial Certificada (ETC)**

ETC/País	A	B	C	D	Omisión y multimarca	N° estudiantes
Amazonas	36.0%	26.5%	19.0%	15.3%	3.2%	627
Antioquia	43.5%	21.2%	20.5%	13.3%	1.6%	19242
Apartadó	39.2%	22.0%	22.9%	14.7%	1.3%	1088
Arauca	49.7%	19.9%	20.2%	9.8%	0.4%	1581
Armenia	50.4%	17.5%	19.5%	11.8%	0.7%	2587
Atlántico	40.1%	23.7%	20.5%	14.6%	1.1%	4931
Barrancabermeja	48.7%	19.0%	19.8%	11.7%	0.9%	1845
Barranquilla	48.3%	18.9%	19.9%	12.1%	0.8%	10592
Bello	47.3%	18.7%	20.1%	12.6%	1.3%	3031
Bogotá, D.C.	55.6%	15.5%	18.8%	9.5%	0.6%	62071
Bolívar	36.7%	25.8%	21.1%	15.1%	1.3%	7541
Boyacá	56.1%	16.0%	18.1%	9.3%	0.5%	7838
Bucaramanga	59.8%	13.0%	18.4%	8.1%	0.6%	4497
Buenaventura	37.9%	24.3%	21.2%	14.7%	1.8%	2787
Buga	52.3%	16.1%	19.3%	11.9%	0.3%	917
Caldas	45.3%	21.7%	19.6%	13.1%	0.4%	4429
Cali	50.3%	18.1%	20.0%	10.6%	0.9%	16580
Caquetá	44.4%	21.2%	21.8%	11.9%	0.7%	1657
Cartagena	41.9%	22.5%	20.8%	13.6%	1.2%	9659
Cartago	51.2%	17.2%	19.6%	11.9%	0.1%	1017
Casanare	51.4%	17.3%	21.2%	9.6%	0.6%	2177
Cauca	43.9%	22.1%	20.5%	12.5%	1.0%	8222
Cesar	42.0%	22.5%	19.9%	15.0%	0.7%	5409
Chocó	33.6%	29.0%	19.7%	15.7%	2.0%	2051
Chía	64.0%	11.9%	17.1%	6.7%	0.3%	1416
Ciénaga	33.0%	26.2%	22.4%	17.5%	0.9%	1060
Cundinamarca	55.0%	15.7%	20.0%	8.9%	0.6%	13372
Córdoba	36.7%	25.7%	20.8%	15.7%	1.2%	8943
Cúcuta	54.8%	16.3%	18.4%	9.8%	0.8%	5733
Dosquebradas	53.5%	17.1%	18.8%	10.2%	0.4%	1319
Duitama	63.5%	12.2%	17.1%	6.8%	0.5%	1251
Envigado	59.1%	12.6%	18.3%	9.4%	0.6%	1633
Facatativá	59.9%	13.2%	18.5%	8.1%	0.3%	1113
Florencia	49.8%	17.3%	21.3%	10.8%	0.9%	1383
Floridablanca	61.0%	12.0%	17.4%	8.6%	1.1%	1982
Fusagasugá	52.7%	17.8%	20.1%	8.5%	0.9%	1119
Girardot	45.0%	20.4%	23.4%	10.6%	0.7%	912

Continúa en la siguiente página

SABER 9 - MATEMÁTICAS

ETC/País	A	B	C	D	Omisión y multimarca	N° estudiantes
Girón	54.8%	16.3%	18.5%	10.2%	0.2%	1109
Guainía	39.9%	26.2%	23.0%	10.4%	0.5%	183
Guaviare	47.2%	23.5%	17.1%	11.6%	0.6%	621
Huila	53.7%	17.4%	18.9%	9.4%	0.6%	5192
Ibagué	53.6%	16.3%	18.9%	10.6%	0.5%	4714
Ipiales	61.6%	13.6%	18.5%	6.2%	0.1%	1066
Itagüí	43.6%	20.3%	20.6%	14.0%	1.4%	1746
Jamundí	47.5%	22.5%	19.8%	9.8%	0.4%	939
La Guajira	36.5%	26.7%	20.9%	15.0%	0.9%	2203
Lorica	34.2%	27.6%	22.3%	15.3%	0.6%	1329
Magangué	38.7%	24.7%	20.3%	14.9%	1.4%	1065
Magdalena	34.3%	26.2%	22.2%	16.0%	1.3%	5904
Maicao	40.2%	23.8%	21.0%	14.6%	0.5%	1178
Malambo	45.6%	19.1%	20.2%	14.4%	0.8%	787
Manizales	47.1%	18.4%	22.1%	11.7%	0.8%	2771
Medellín	47.1%	18.6%	19.7%	13.3%	1.4%	17124
Meta	49.4%	17.6%	21.3%	10.9%	0.9%	3790
Montería	44.1%	19.6%	20.8%	14.6%	0.9%	4178
Mosquera	60.4%	13.0%	18.1%	8.2%	0.3%	1158
Nariño	51.8%	17.9%	20.5%	9.1%	0.7%	6043
Neiva	59.6%	14.1%	17.5%	8.5%	0.3%	2950
Norte de Santander	51.8%	17.7%	19.7%	10.1%	0.6%	5090
Palmira	56.3%	14.1%	19.2%	9.9%	0.5%	2329
Pasto	61.5%	13.6%	16.6%	7.5%	0.8%	3212
Pereira	54.2%	16.3%	19.2%	9.9%	0.4%	3749
Piedecuesta	56.2%	14.5%	19.3%	8.7%	1.3%	1186
Pitalito	54.2%	14.9%	22.1%	7.9%	0.9%	1067
Popayán	57.1%	14.7%	19.2%	8.5%	0.7%	2459
Putumayo	52.0%	17.7%	19.4%	9.9%	1.0%	2701
Quibdó	29.3%	27.2%	23.6%	17.2%	2.8%	1086
Quindío	43.5%	19.7%	22.5%	13.8%	0.6%	2039
Riohacha	43.8%	21.9%	20.4%	12.7%	1.1%	1341
Rionegro	52.4%	16.7%	20.7%	9.7%	0.6%	1086
Risaralda	42.7%	22.2%	21.0%	13.2%	0.9%	1936
Sabaneta	57.3%	13.7%	18.5%	9.5%	1.0%	496
Sahagún	42.7%	20.9%	21.6%	14.1%	0.6%	1079
San Andrés	38.9%	22.5%	23.8%	14.6%	0.2%	529
Santa Marta	39.3%	20.9%	23.2%	15.2%	1.4%	4355
Santander	56.0%	15.9%	18.4%	9.3%	0.5%	6431

Continúa en la siguiente página



ETC/País	A	B	C	D	Omisión y multimarca	N° estudiantes
Sincelejo	46.6%	21.0%	18.9%	12.8%	0.7%	2696
Soacha	50.5%	18.0%	19.9%	10.4%	1.1%	4802
Sogamoso	62.8%	11.6%	18.5%	6.7%	0.3%	1267
Soledad	46.7%	19.3%	20.2%	12.8%	1.1%	4098
Sucre	39.0%	25.9%	20.8%	13.4%	0.8%	5462
Tolima	45.5%	20.8%	20.5%	12.4%	0.8%	6958
Tuluá	46.2%	18.3%	24.0%	11.1%	0.4%	1832
Tumaco	32.5%	28.6%	20.7%	16.9%	1.3%	1334
Tunja	59.1%	13.6%	17.9%	8.9%	0.5%	1740
Turbo	30.8%	31.3%	20.3%	16.2%	1.4%	1254
Uribe	40.8%	25.5%	17.3%	15.7%	0.7%	306
Valle del Cauca	47.0%	20.1%	20.4%	11.7%	0.8%	6252
Valledupar	45.0%	21.3%	20.5%	12.7%	0.5%	4092
Vichada	41.1%	25.5%	18.8%	13.9%	0.7%	404
Villavicencio	56.0%	15.3%	19.1%	8.8%	0.8%	4110
Yopal	57.1%	16.3%	18.2%	8.1%	0.2%	1395
Yumbo	50.7%	17.9%	19.5%	11.0%	1.0%	894
Zipaquirá	61.2%	13.9%	18.2%	6.3%	0.4%	1155
Colombia	49.1%	18.8%	19.8%	11.4%	0.9%	381884

*Es posible que los porcentajes mostrados no sumen exactamente 100 debido a aproximaciones decimales.

• **Pregunta 25.**

Alberto va a participar en un torneo de tiro al blanco con lanzamiento de dardos, utilizando un tablero como el que aparece en la ilustración.

En una de sus prácticas, Alberto registró las veces que cayó el dardo en cada zona.

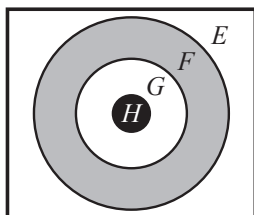

Figura

Zona del tablero	Aciertos
<i>E</i>	
<i>F</i>	
<i>G</i>	
<i>H</i>	

Tabla

De acuerdo con las observaciones si el dardo cayó en el tablero, la probabilidad de que haya caído en la zona *E* fue

- A. igual que la probabilidad de que haya caído en la zona *F* o en la *H*.
- B. mayor que la probabilidad de que haya caído en la zona *G* o en la *H*.
- C. igual que la probabilidad de que haya caído en la zona *H*.
- D. menor que la probabilidad de que haya caído en la zona *G*.

• **Estructura**

Competencia	Razonamiento
Componente	Aleatorio
Afirmación	Utilizar diferentes métodos y estrategias para calcular la probabilidad de eventos simples.
Nivel de desempeño	Satisfactorio
Respuesta Correcta	B

• **Resultados a nivel nacional y de Entidad Territorial Certificada (ETC)**

ETC/País	A	B	C	D	Omisión y multimarca	N° estudiantes
Amazonas	18.7%	49.8%	14.5%	14.7%	2.4%	627
Antioquia	16.4%	58.2%	12.5%	11.6%	1.3%	19242
Apartadó	18.3%	52.3%	14.3%	14.2%	0.8%	1088
Arauca	13.6%	61.9%	11.8%	12.3%	0.3%	1581
Armenia	15.0%	63.3%	10.6%	10.4%	0.8%	2587
Atlántico	17.2%	53.1%	15.0%	13.7%	1.0%	4931
Barrancabermeja	14.0%	61.7%	12.7%	10.8%	0.8%	1845
Barranquilla	14.8%	61.8%	11.1%	11.6%	0.7%	10592
Bello	13.8%	62.8%	11.5%	10.8%	1.2%	3031
Bogotá, D.C.	13.4%	68.4%	8.6%	9.1%	0.5%	62071
Bolívar	19.2%	50.2%	15.5%	13.9%	1.2%	7541
Boyacá	13.3%	65.6%	9.5%	11.4%	0.3%	7838
Bucaramanga	11.4%	70.9%	8.5%	8.6%	0.6%	4497
Buenaventura	18.2%	52.7%	14.0%	14.0%	1.0%	2787
Buga	16.6%	63.1%	9.9%	9.9%	0.4%	917
Caldas	16.6%	59.1%	11.6%	12.3%	0.3%	4429
Cali	14.9%	63.1%	10.5%	10.7%	0.8%	16580
Caquetá	17.2%	53.5%	14.8%	14.1%	0.4%	1657
Cartagena	17.2%	57.0%	12.9%	11.9%	0.9%	9659
Cartago	14.1%	66.8%	8.9%	9.9%	0.3%	1017
Casanare	15.4%	60.8%	10.5%	12.9%	0.4%	2177
Cauca	18.5%	53.4%	13.1%	14.2%	0.8%	8222
Cesar	17.0%	54.0%	15.5%	13.0%	0.5%	5409
Chocó	18.0%	48.0%	16.3%	15.8%	1.9%	2051
Chía	10.7%	74.6%	6.5%	7.7%	0.4%	1416
Ciénaga	19.2%	49.7%	15.1%	15.0%	1.0%	1060
Cundinamarca	13.6%	67.2%	8.9%	9.9%	0.4%	13372
Córdoba	18.6%	51.3%	15.1%	14.1%	0.9%	8943
Cúcuta	13.8%	64.8%	10.4%	10.3%	0.7%	5733
Dosquebradas	12.7%	69.5%	8.4%	9.0%	0.4%	1319
Duitama	11.4%	73.1%	7.7%	7.7%	0.2%	1251
Envigado	11.6%	71.8%	9.2%	7.2%	0.2%	1633
Facatativá	14.2%	68.0%	7.4%	10.2%	0.3%	1113
Florencia	15.0%	61.0%	10.4%	12.9%	0.7%	1383
Floridablanca	10.8%	72.1%	7.7%	8.4%	1.0%	1982
Fusagasugá	13.4%	67.4%	9.1%	9.6%	0.5%	1119
Girardot	18.0%	58.4%	10.3%	12.6%	0.7%	912

Continúa en la siguiente página

SABER 9 - MATEMÁTICAS

ETC/País	A	B	C	D	Omisión y multimarca	N° estudiantes
Girón	13.3%	66.7%	9.8%	9.7%	0.5%	1109
Guainía	17.5%	49.7%	12.6%	18.0%	2.2%	183
Guaviare	15.0%	58.5%	12.7%	13.0%	0.8%	621
Huila	14.9%	62.1%	10.0%	12.5%	0.4%	5192
Ibagué	14.3%	65.6%	10.0%	9.6%	0.5%	4714
Ipiales	12.5%	65.0%	9.7%	12.2%	0.7%	1066
Itagüí	16.7%	60.0%	12.3%	9.8%	1.1%	1746
Jamundí	19.1%	60.3%	9.4%	10.8%	0.5%	939
La Guajira	18.5%	51.1%	16.6%	13.1%	0.7%	2203
Lorica	20.0%	47.7%	17.3%	14.7%	0.3%	1329
Magangué	18.6%	53.1%	12.2%	14.9%	1.2%	1065
Magdalena	18.1%	50.4%	15.5%	14.8%	1.3%	5904
Maicao	19.7%	55.0%	13.1%	11.7%	0.5%	1178
Malambo	19.9%	53.2%	12.6%	13.3%	0.9%	787
Manizales	14.7%	63.0%	11.4%	10.3%	0.5%	2771
Medellín	15.4%	61.9%	11.4%	10.1%	1.2%	17124
Meta	15.2%	62.0%	10.9%	11.3%	0.6%	3790
Montería	16.0%	59.2%	12.1%	11.9%	0.8%	4178
Mosquera	13.1%	69.9%	7.8%	8.9%	0.3%	1158
Nariño	13.5%	63.9%	9.5%	12.4%	0.7%	6043
Neiva	13.7%	67.2%	8.3%	10.3%	0.4%	2950
Norte de Santander	14.5%	63.4%	9.8%	11.7%	0.6%	5090
Palmira	12.8%	68.1%	9.4%	9.4%	0.3%	2329
Pasto	14.1%	66.5%	8.1%	10.6%	0.6%	3212
Pereira	13.7%	67.0%	10.0%	8.7%	0.7%	3749
Piedecuesta	11.8%	66.8%	10.5%	9.9%	0.9%	1186
Pitalito	12.8%	68.1%	9.1%	9.4%	0.6%	1067
Popayán	14.9%	64.5%	10.4%	9.9%	0.4%	2459
Putumayo	14.8%	61.1%	11.2%	12.0%	1.0%	2701
Quibdó	16.6%	50.1%	15.3%	15.2%	2.9%	1086
Quindío	16.9%	58.2%	12.3%	12.2%	0.5%	2039
Riohacha	15.3%	59.7%	11.3%	12.8%	1.0%	1341
Rionegro	12.2%	67.2%	9.9%	10.2%	0.5%	1086
Risaralda	17.2%	59.0%	9.7%	13.5%	0.7%	1936
Sabaneta	10.3%	74.2%	7.9%	6.7%	1.0%	496
Sahagún	15.8%	54.9%	14.3%	14.8%	0.3%	1079
San Andrés	18.9%	51.4%	16.8%	12.9%	0.0%	529
Santa Marta	17.2%	57.1%	13.1%	11.5%	1.1%	4355
Santander	13.2%	65.7%	10.0%	10.8%	0.3%	6431

Continúa en la siguiente página



ETC/País	A	B	C	D	Omisión y multimarca	N° estudiantes
Sincelejo	16.2%	60.3%	12.6%	10.5%	0.4%	2696
Soacha	16.3%	62.7%	10.1%	9.9%	0.9%	4802
Sogamoso	12.2%	70.6%	8.1%	8.9%	0.2%	1267
Soledad	16.8%	60.2%	11.3%	10.6%	1.2%	4098
Sucre	18.2%	52.7%	14.2%	14.3%	0.6%	5462
Tolima	18.0%	56.3%	11.9%	13.1%	0.7%	6958
Tuluá	15.7%	62.2%	10.6%	10.9%	0.6%	1832
Tumaco	20.5%	47.8%	15.7%	15.1%	1.0%	1334
Tunja	11.3%	73.0%	7.8%	7.8%	0.0%	1740
Turbo	20.3%	48.8%	15.2%	14.9%	0.9%	1254
Uribe	19.9%	51.3%	16.0%	12.4%	0.3%	306
Valle del Cauca	17.3%	58.6%	11.3%	12.2%	0.6%	6252
Valledupar	16.1%	59.8%	10.8%	12.7%	0.7%	4092
Vichada	16.8%	54.0%	12.1%	16.8%	0.2%	404
Villavicencio	14.5%	65.2%	9.5%	10.2%	0.5%	4110
Yopal	15.1%	66.8%	9.2%	8.5%	0.4%	1395
Yumbo	17.1%	60.3%	10.9%	10.9%	0.9%	894
Zipaquirá	10.4%	72.4%	6.9%	10.1%	0.2%	1155
Colombia	15.3%	61.8%	11.0%	11.2%	0.7%	381884

*Es posible que los porcentajes mostrados no sumen exactamente 100 debido a aproximaciones decimales.

• **Pregunta 26.**

A continuación se presenta una gráfica publicada por la UNICEF que relaciona edad (en meses) de los niños y peso (en kilogramos) mínimo y máximo esperado.

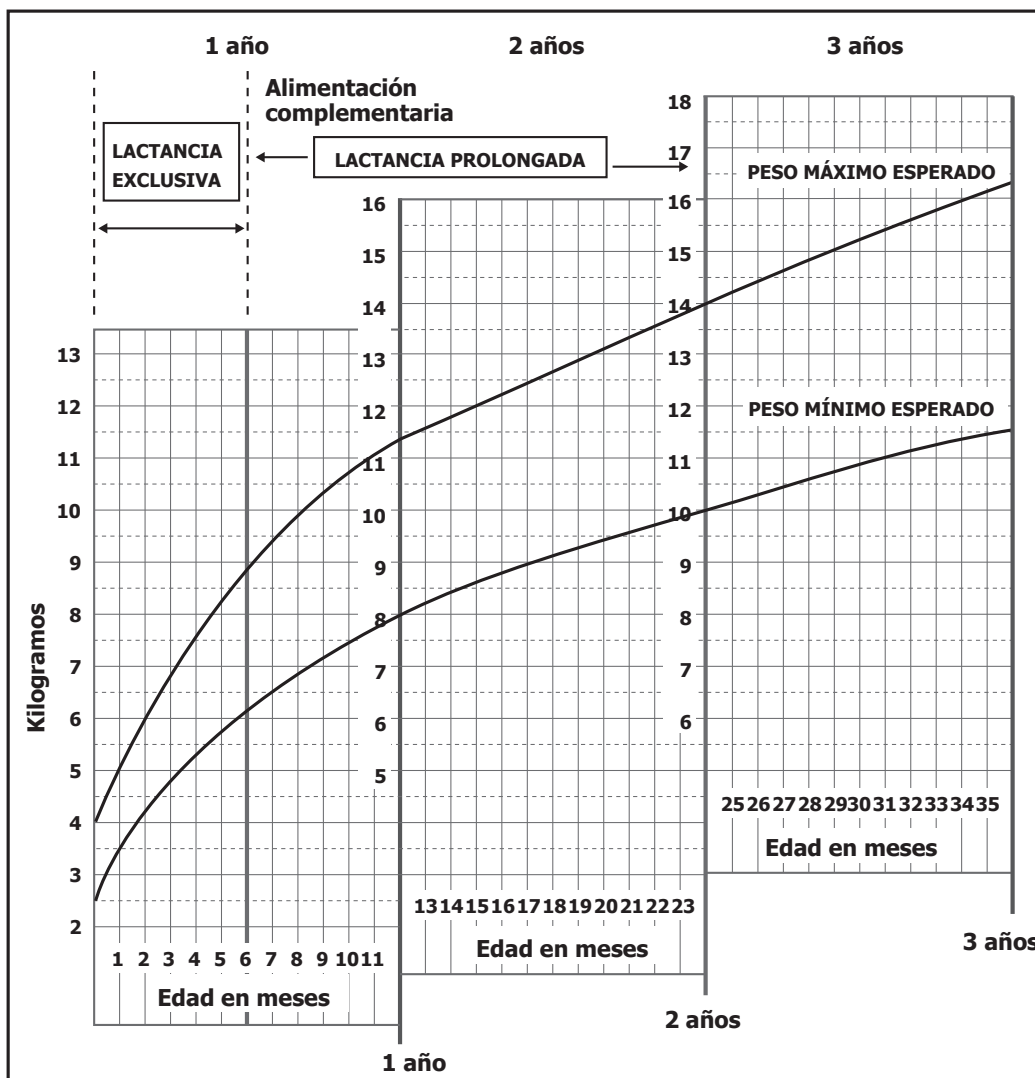

Gráfica

De la información presentada en la gráfica, es correcto concluir que

- A. de los 0 a los 3 años, el peso mínimo de un niño debería duplicarse.
- B. entre 1 y 2 años el aumento de peso máximo esperado es 14 kilos.
- C. a los 6 meses un niño debería pesar entre 6 y 9 kilos.
- D. a los 2 años, un niño debería pesar mínimo 14 kilos.

- **Estructura**

Competencia	Comunicación
Componente	Espacial - métrico
Afirmación	Identificar relaciones entre distintas unidades utilizadas para medir cantidades de la misma magnitud.
Nivel de desempeño	Avanzado
Respuesta Correcta	C

- **Resultados a nivel nacional y de Entidad Territorial Certificada (ETC)**

ETC/País	A	B	C	D	Omisión y multimarca	Nº estudiantes
Amazonas	19.6%	26.5%	30.0%	21.4%	2.6%	627
Antioquia	20.0%	25.9%	32.2%	20.3%	1.7%	19242
Apartadó	22.3%	27.6%	30.9%	17.8%	1.4%	1088
Arauca	17.6%	28.8%	33.1%	20.1%	0.4%	1581
Armenia	19.2%	25.4%	37.8%	16.6%	1.0%	2587
Atlántico	19.8%	27.6%	30.7%	20.2%	1.7%	4931
Barrancabermeja	19.9%	26.3%	35.2%	17.7%	0.8%	1845
Barranquilla	19.5%	26.9%	35.3%	17.1%	1.2%	10592
Bello	20.4%	27.6%	34.8%	15.5%	1.7%	3031
Bogotá, D.C.	17.4%	26.0%	41.3%	14.5%	0.9%	62071
Bolívar	19.2%	26.7%	29.7%	22.8%	1.6%	7541
Boyacá	15.6%	26.6%	38.2%	19.0%	0.7%	7838
Bucaramanga	15.6%	26.1%	43.6%	13.8%	0.9%	4497
Buenaventura	20.1%	28.0%	27.8%	22.0%	2.1%	2787
Buga	19.0%	26.3%	34.9%	18.9%	1.0%	917
Caldas	19.8%	26.0%	32.5%	21.2%	0.5%	4429
Cali	19.1%	26.2%	36.5%	16.8%	1.3%	16580
Caquetá	20.3%	28.6%	28.0%	22.0%	1.1%	1657
Cartagena	20.3%	27.5%	31.9%	18.7%	1.5%	9659
Cartago	18.2%	27.3%	36.9%	17.0%	0.6%	1017
Casanare	19.9%	28.6%	31.5%	19.4%	0.6%	2177
Cauca	18.7%	27.3%	30.6%	22.0%	1.3%	8222
Cesar	19.4%	27.5%	31.2%	21.3%	0.7%	5409
Chocó	22.6%	25.7%	25.6%	24.1%	2.0%	2051
Chía	14.3%	23.5%	48.0%	13.6%	0.7%	1416
Ciénaga	23.2%	27.1%	23.9%	24.7%	1.1%	1060

Continúa en la siguiente página

SABER 9 - MATEMÁTICAS

ETC/País	A	B	C	D	Omisión y multimarca	N° estudiantes
Cundinamarca	16.4%	26.9%	39.3%	16.6%	0.8%	13372
Córdoba	18.5%	27.1%	30.3%	22.8%	1.3%	8943
Cúcuta	16.4%	26.9%	38.0%	17.4%	1.3%	5733
Dosquebradas	17.6%	25.0%	37.8%	18.8%	0.8%	1319
Duitama	13.7%	26.2%	48.8%	11.0%	0.2%	1251
Envigado	16.6%	23.8%	47.9%	11.1%	0.6%	1633
Facatativá	17.6%	26.4%	38.7%	16.8%	0.4%	1113
Florencia	16.8%	29.3%	33.3%	19.5%	1.1%	1383
Floridablanca	15.7%	26.9%	43.0%	13.6%	0.8%	1982
Fusagasugá	19.0%	24.1%	41.5%	14.7%	0.7%	1119
Girardot	19.3%	29.4%	30.4%	19.8%	1.1%	912
Girón	20.7%	25.8%	36.3%	16.5%	0.6%	1109
Guainía	21.9%	31.1%	27.3%	19.1%	0.5%	183
Guaviare	19.6%	26.6%	30.4%	22.5%	0.8%	621
Huila	17.2%	28.6%	33.8%	19.8%	0.6%	5192
Ibagué	18.1%	26.5%	37.7%	17.0%	0.7%	4714
Ipiales	14.3%	28.0%	40.1%	17.0%	0.7%	1066
Itagüí	20.0%	24.9%	37.8%	15.6%	1.6%	1746
Jamundí	18.4%	31.0%	31.6%	18.3%	0.6%	939
La Guajira	21.5%	26.7%	29.6%	21.0%	1.2%	2203
Lorica	19.0%	27.4%	27.2%	25.7%	0.8%	1329
Magangué	19.9%	27.3%	29.7%	21.4%	1.7%	1065
Magdalena	20.5%	26.2%	28.3%	23.3%	1.7%	5904
Maicao	18.8%	27.2%	27.9%	24.4%	1.6%	1178
Malambo	20.1%	29.6%	30.1%	19.1%	1.1%	787
Manizales	18.7%	25.3%	37.2%	17.8%	1.0%	2771
Medellín	20.0%	25.5%	36.0%	16.9%	1.6%	17124
Meta	17.9%	27.6%	35.2%	18.3%	1.0%	3790
Montería	18.8%	26.5%	33.9%	19.6%	1.2%	4178
Mosquera	19.2%	22.4%	43.3%	14.5%	0.7%	1158
Nariño	15.8%	26.7%	35.7%	20.7%	1.1%	6043
Neiva	15.9%	28.8%	37.9%	16.6%	0.7%	2950
Norte de Santander	17.6%	26.4%	35.0%	20.3%	0.7%	5090
Palmira	17.1%	28.3%	38.5%	15.1%	1.0%	2329
Pasto	16.9%	26.4%	39.3%	16.3%	1.1%	3212
Pereira	18.1%	25.6%	38.1%	17.2%	1.0%	3749
Piedecuesta	15.4%	26.3%	39.7%	17.1%	1.4%	1186
Pitalito	17.0%	31.1%	36.4%	15.0%	0.6%	1067
Popayán	18.5%	26.8%	36.6%	16.8%	1.3%	2459

Continúa en la siguiente página



ETC/País	A	B	C	D	Omisión y multimarca	N° estudiantes
Putumayo	17.3%	27.9%	33.7%	19.8%	1.3%	2701
Quibdó	19.0%	27.3%	26.9%	23.7%	3.1%	1086
Quindío	17.5%	28.2%	34.3%	19.2%	0.7%	2039
Riohacha	19.2%	30.0%	30.1%	19.6%	1.1%	1341
Rionegro	18.2%	26.2%	39.0%	16.2%	0.5%	1086
Risaralda	19.7%	25.2%	33.4%	20.9%	0.9%	1936
Sabaneta	16.7%	25.4%	43.1%	13.5%	1.2%	496
Sahagún	16.1%	28.4%	33.1%	21.9%	0.6%	1079
San Andrés	19.7%	32.7%	28.0%	18.5%	1.1%	529
Santa Marta	20.5%	26.8%	32.1%	19.1%	1.5%	4355
Santander	16.5%	27.4%	37.0%	18.5%	0.6%	6431
Sincelejo	21.1%	26.5%	32.0%	19.5%	0.9%	2696
Soacha	19.2%	27.3%	35.8%	16.3%	1.4%	4802
Sogamoso	15.0%	28.1%	43.9%	12.9%	0.2%	1267
Soledad	19.2%	27.1%	34.3%	17.8%	1.6%	4098
Sucre	19.4%	26.7%	29.2%	24.0%	0.8%	5462
Tolima	18.8%	27.6%	32.2%	20.4%	1.0%	6958
Tuluá	18.4%	24.7%	37.6%	18.3%	1.0%	1832
Tumaco	22.4%	25.0%	26.2%	24.1%	2.2%	1334
Tunja	15.6%	25.1%	42.5%	16.3%	0.5%	1740
Turbo	22.4%	26.3%	26.6%	23.3%	1.4%	1254
Uribe	17.3%	24.8%	32.7%	23.5%	1.6%	306
Valle del Cauca	19.7%	26.6%	32.4%	20.4%	1.0%	6252
Valledupar	21.0%	26.6%	32.2%	19.0%	1.2%	4092
Vichada	22.0%	20.8%	32.4%	23.0%	1.7%	404
Villavicencio	16.8%	28.3%	38.3%	15.6%	0.9%	4110
Yopal	15.4%	26.1%	41.4%	16.5%	0.6%	1395
Yumbo	20.6%	27.2%	31.7%	19.4%	1.2%	894
Zipaquirá	17.5%	26.4%	41.5%	14.0%	0.6%	1155
Colombia	18.4%	26.6%	35.7%	18.1%	1.1%	381884

*Es posible que los porcentajes mostrados no sumen exactamente 100 debido a aproximaciones decimales.

• **Pregunta 27.**

La figura muestra los tres primeros pasos de una secuencia de construcción de cuadrados:

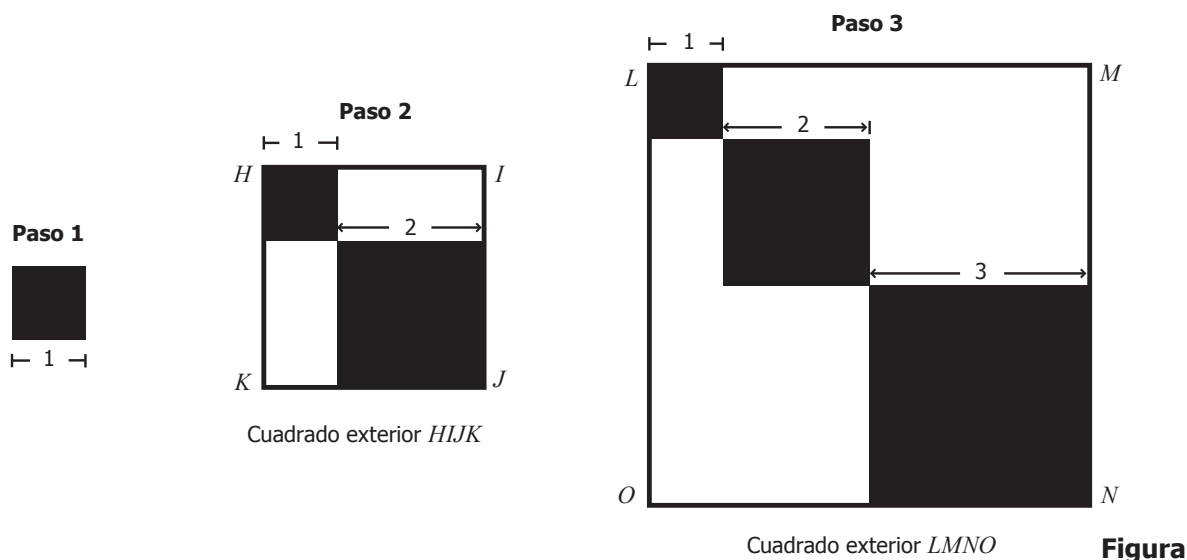

Si continua la secuencia, ¿cuánto mide el lado del cuadrado exterior en el paso 4?

- A. 8
- B. 9
- C. 10
- D. 12

• **Estructura**

Competencia	Razonamiento
Componente	Espacial - métrico
Afirmación	Argumentar formal e informalmente sobre propiedades y relaciones de figuras planas y sólidos.
Nivel de desempeño	Avanzado
Respuesta Correcta	C

• Resultados a nivel nacional y de Entidad Territorial Certificada (ETC)

ETC/País	A	B	C	D	Omisión y multimarca	N° estudiantes
Amazonas	32.7%	15.6%	27.1%	22.0%	2.6%	627
Antioquia	29.3%	18.2%	30.7%	20.1%	1.7%	19242
Apartadó	27.8%	21.0%	31.3%	19.0%	0.8%	1088
Arauca	26.9%	20.2%	33.0%	19.5%	0.4%	1581
Armenia	26.6%	18.1%	37.0%	17.3%	1.0%	2587
Atlántico	29.2%	19.8%	30.4%	19.0%	1.6%	4931
Barrancabermeja	25.4%	19.3%	38.0%	16.3%	1.0%	1845
Barranquilla	27.5%	19.3%	34.5%	17.5%	1.2%	10592
Bello	28.1%	19.1%	35.2%	16.3%	1.3%	3031
Bogotá, D.C.	24.9%	16.4%	43.2%	14.8%	0.7%	62071
Bolívar	28.1%	19.8%	27.6%	23.1%	1.4%	7541
Boyacá	27.4%	18.0%	34.7%	19.5%	0.4%	7838
Bucaramanga	24.5%	15.8%	44.2%	14.7%	0.7%	4497
Buenaventura	29.5%	18.2%	28.1%	22.2%	1.9%	2787
Buga	24.3%	19.4%	39.3%	16.5%	0.5%	917
Caldas	29.6%	17.7%	31.4%	20.8%	0.5%	4429
Cali	26.1%	18.6%	37.7%	16.6%	1.0%	16580
Caquetá	28.4%	18.1%	31.9%	20.9%	0.7%	1657
Cartagena	28.1%	20.1%	32.9%	17.6%	1.3%	9659
Cartago	25.7%	17.5%	37.4%	18.7%	0.8%	1017
Casanare	29.1%	18.0%	33.4%	18.8%	0.6%	2177
Cauca	29.5%	18.7%	28.8%	21.9%	1.2%	8222
Cesar	30.4%	20.6%	28.2%	20.1%	0.6%	5409
Chocó	29.7%	18.9%	25.0%	24.6%	1.8%	2051
Chía	20.3%	14.3%	50.9%	13.8%	0.7%	1416
Ciénaga	31.5%	17.5%	27.6%	21.3%	2.0%	1060
Cundinamarca	27.0%	16.6%	38.9%	17.0%	0.6%	13372
Córdoba	28.1%	19.9%	27.7%	23.0%	1.3%	8943
Cúcuta	26.7%	18.0%	37.1%	17.1%	1.0%	5733
Dosquebradas	26.8%	17.3%	36.0%	19.3%	0.6%	1319
Duitama	24.7%	14.6%	44.9%	15.6%	0.2%	1251
Envigado	19.5%	17.6%	47.9%	14.5%	0.4%	1633
Facatativá	25.6%	18.8%	40.2%	14.9%	0.5%	1113
Florencia	29.1%	18.7%	33.6%	17.9%	0.8%	1383
Floridablanca	22.5%	14.9%	47.9%	14.1%	0.6%	1982
Fusagasugá	25.4%	19.7%	38.6%	15.5%	0.8%	1119
Girardot	27.6%	18.6%	34.9%	18.0%	0.9%	912

Continúa en la siguiente página

SABER 9 - MATEMÁTICAS

ETC/País	A	B	C	D	Omisión y multimarca	N° estudiantes
Girón	29.1%	17.2%	34.4%	18.8%	0.5%	1109
Guainía	26.8%	23.0%	31.1%	18.0%	1.1%	183
Guaviare	30.0%	16.3%	30.8%	22.5%	0.5%	621
Huila	29.5%	18.2%	33.2%	18.6%	0.5%	5192
Ibagué	27.6%	17.0%	37.9%	17.0%	0.5%	4714
Ipiales	25.1%	19.9%	35.6%	19.0%	0.3%	1066
Itagüí	30.1%	19.9%	30.0%	18.8%	1.3%	1746
Jamundí	30.4%	19.9%	30.9%	18.2%	0.6%	939
La Guajira	28.4%	19.4%	28.9%	22.0%	1.3%	2203
Lorica	32.6%	20.8%	25.1%	21.1%	0.5%	1329
Magangué	29.8%	20.8%	28.5%	19.1%	1.8%	1065
Magdalena	28.0%	20.2%	27.9%	22.4%	1.4%	5904
Maicao	33.0%	17.6%	27.8%	20.7%	0.9%	1178
Malambo	25.7%	15.1%	39.1%	19.1%	1.0%	787
Manizales	28.9%	17.5%	34.9%	18.0%	0.6%	2771
Medellín	27.1%	18.5%	35.7%	17.2%	1.5%	17124
Meta	27.0%	19.1%	34.2%	18.8%	0.9%	3790
Montería	28.2%	18.8%	31.5%	20.4%	1.0%	4178
Mosquera	22.0%	18.1%	44.2%	15.2%	0.4%	1158
Nariño	27.0%	17.6%	33.8%	20.9%	0.7%	6043
Neiva	25.7%	18.3%	38.6%	16.6%	0.7%	2950
Norte de Santander	30.5%	17.4%	33.2%	18.3%	0.7%	5090
Palmira	24.5%	17.0%	41.9%	16.0%	0.7%	2329
Pasto	26.0%	17.3%	40.0%	16.0%	0.8%	3212
Pereira	26.9%	17.6%	39.9%	15.2%	0.5%	3749
Piedecuesta	26.9%	16.1%	38.2%	17.5%	1.3%	1186
Pitalito	28.0%	17.7%	35.3%	18.1%	0.8%	1067
Popayán	24.2%	17.9%	41.1%	16.1%	0.7%	2459
Putumayo	27.3%	18.7%	32.9%	20.0%	1.1%	2701
Quibdó	31.9%	17.2%	26.2%	21.3%	3.5%	1086
Quindío	28.0%	19.6%	31.6%	20.0%	0.8%	2039
Riohacha	25.7%	19.6%	32.5%	20.9%	1.3%	1341
Rionegro	25.8%	17.5%	38.4%	17.7%	0.6%	1086
Risaralda	30.7%	18.8%	30.5%	19.1%	0.9%	1936
Sabaneta	23.8%	18.1%	42.3%	14.5%	1.2%	496
Sahagún	29.3%	19.9%	28.6%	21.5%	0.6%	1079
San Andrés	31.2%	22.3%	25.1%	20.8%	0.6%	529
Santa Marta	28.8%	19.0%	32.3%	18.3%	1.6%	4355
Santander	27.3%	18.3%	35.8%	18.3%	0.3%	6431

Continúa en la siguiente página



ETC/País	A	B	C	D	Omisión y multimarca	N° estudiantes
Sincelejo	28.7%	20.0%	31.2%	19.4%	0.7%	2696
Soacha	27.3%	18.0%	38.5%	15.0%	1.2%	4802
Sogamoso	28.8%	16.6%	39.4%	14.8%	0.5%	1267
Soledad	29.0%	18.9%	33.7%	17.1%	1.3%	4098
Sucre	28.6%	19.2%	27.5%	23.7%	0.9%	5462
Tolima	30.0%	18.2%	31.4%	19.5%	0.9%	6958
Tuluá	25.6%	17.9%	39.1%	16.4%	0.9%	1832
Tumaco	27.7%	18.0%	30.1%	22.6%	1.6%	1334
Tunja	24.7%	16.3%	43.9%	14.9%	0.2%	1740
Turbo	31.8%	20.7%	26.1%	20.1%	1.3%	1254
Uribe	33.3%	13.4%	24.5%	28.4%	0.3%	306
Valle del Cauca	28.1%	18.9%	32.1%	20.2%	0.8%	6252
Valledupar	29.3%	19.6%	31.9%	18.3%	0.9%	4092
Vichada	29.5%	17.1%	26.0%	26.5%	1.0%	404
Villavicencio	24.7%	18.4%	40.4%	15.8%	0.6%	4110
Yopal	26.9%	15.9%	40.3%	16.7%	0.2%	1395
Yumbo	27.7%	17.1%	35.9%	17.8%	1.5%	894
Zipaquirá	22.9%	13.7%	50.2%	13.1%	0.2%	1155
Colombia	27.3%	18.1%	35.6%	18.1%	0.9%	381884

*Es posible que los porcentajes mostrados no sumen exactamente 100 debido a aproximaciones decimales.

• **Pregunta 28.**

La montaña submarina más alta del mundo está ubicada cerca de Nueva Zelanda. La montaña tiene una altura de 8.690 metros y sobresale 300 metros fuera del agua. Para encontrar la altura sumergida (h) de la montaña, cuatro estudiantes plantearon las siguientes ecuaciones:

- Laura: $h - 8.690 = 300$
 Alejandro: $8.690 - h = 300$
 Vanesa: $h + 300 = 8.690$
 Camilo: $h + 8.690 = 300$



¿Cuáles estudiantes formularon correctamente las ecuaciones para hallar el valor de h ?

- A. Alejandro y Vanesa.
- B. Laura y Vanesa.
- C. Alejandro y Camilo.
- D. Laura y Camilo.

• **Estructura**

Competencia	Resolución
Componente	Numérico - variacional
Afirmación	Resuelve problemas en situaciones aditivas y multiplicativas en el conjunto de los números reales.
Nivel de desempeño	Avanzado
Respuesta Correcta	A

• Resultados a nivel nacional y de Entidad Territorial Certificada (ETC)

ETC/País	A	B	C	D	Omisión y multimarca	N° estudiantes
Amazonas	24.4%	23.9%	19.8%	29.7%	2.2%	627
Antioquia	28.2%	26.5%	18.2%	25.8%	1.4%	19242
Apartadó	27.5%	27.8%	17.8%	26.0%	0.9%	1088
Arauca	26.0%	26.9%	16.8%	29.7%	0.6%	1581
Armenia	30.8%	28.1%	17.3%	23.0%	0.9%	2587
Atlántico	28.0%	26.5%	17.3%	27.2%	1.0%	4931
Barrancabermeja	32.9%	27.8%	15.3%	23.1%	0.9%	1845
Barranquilla	32.6%	26.7%	16.8%	23.1%	0.8%	10592
Bello	32.7%	28.0%	16.6%	21.4%	1.3%	3031
Bogotá, D.C.	34.7%	28.1%	15.5%	21.0%	0.7%	62071
Bolívar	25.9%	25.1%	18.3%	29.3%	1.4%	7541
Boyacá	29.8%	27.9%	17.1%	24.6%	0.5%	7838
Bucaramanga	36.7%	28.1%	15.2%	19.2%	0.8%	4497
Buenaventura	26.1%	26.7%	18.0%	27.8%	1.3%	2787
Buga	30.5%	28.7%	16.9%	23.4%	0.4%	917
Caldas	27.6%	26.9%	18.3%	26.7%	0.5%	4429
Cali	32.4%	27.6%	16.7%	22.2%	1.0%	16580
Caquetá	26.8%	28.4%	20.1%	24.1%	0.6%	1657
Cartagena	31.4%	26.2%	16.1%	25.3%	1.1%	9659
Cartago	29.7%	28.3%	16.9%	24.4%	0.7%	1017
Casanare	28.0%	26.6%	17.7%	27.1%	0.6%	2177
Cauca	27.1%	25.9%	18.4%	27.6%	1.0%	8222
Cesar	28.5%	25.8%	17.6%	27.7%	0.3%	5409
Chocó	24.6%	22.6%	21.1%	30.4%	1.4%	2051
Chía	38.6%	27.6%	15.0%	18.2%	0.6%	1416
Ciénaga	27.2%	25.3%	18.0%	28.5%	1.0%	1060
Cundinamarca	32.1%	27.2%	16.2%	24.0%	0.5%	13372
Córdoba	26.2%	24.8%	19.0%	29.1%	0.8%	8943
Cúcuta	32.8%	26.6%	15.4%	24.3%	0.9%	5733
Dosquebradas	29.5%	27.7%	18.3%	23.9%	0.6%	1319
Duitama	36.3%	29.0%	15.0%	19.3%	0.3%	1251
Envigado	42.8%	25.0%	14.4%	17.3%	0.4%	1633
Facatativá	31.0%	29.8%	15.5%	23.2%	0.5%	1113
Florencia	28.9%	28.9%	17.0%	24.3%	0.9%	1383
Floridablanca	37.7%	27.4%	14.0%	19.9%	1.0%	1982
Fusagasugá	30.5%	29.2%	17.6%	22.0%	0.7%	1119
Girardot	26.0%	27.0%	18.4%	27.7%	0.9%	912

Continúa en la siguiente página

SABER 9 - MATEMÁTICAS

ETC/País	A	B	C	D	Omisión y multimarca	N° estudiantes
Girón	32.5%	25.7%	16.4%	25.0%	0.5%	1109
Guainía	20.8%	27.9%	19.1%	32.2%	0.0%	183
Guaviare	26.1%	25.1%	18.4%	29.8%	0.6%	621
Huila	26.5%	26.4%	18.0%	28.5%	0.6%	5192
Ibagué	30.3%	27.9%	16.6%	24.6%	0.6%	4714
Ipiales	29.0%	31.9%	17.1%	21.6%	0.5%	1066
Itagüí	33.8%	27.9%	14.5%	22.5%	1.3%	1746
Jamundí	29.7%	26.4%	17.9%	25.5%	0.5%	939
La Guajira	27.2%	25.2%	17.0%	29.6%	0.9%	2203
Lorica	22.6%	26.5%	19.6%	30.4%	0.8%	1329
Magangué	25.5%	21.8%	20.6%	30.4%	1.7%	1065
Magdalena	26.6%	24.3%	18.4%	29.4%	1.3%	5904
Maicao	26.7%	25.8%	19.0%	27.9%	0.6%	1178
Malambo	33.3%	23.4%	15.5%	26.9%	0.9%	787
Manizales	29.4%	28.6%	17.6%	23.8%	0.5%	2771
Medellín	33.1%	27.4%	16.0%	22.1%	1.4%	17124
Meta	28.5%	27.5%	17.3%	26.0%	0.8%	3790
Montería	30.6%	25.9%	16.8%	25.5%	1.1%	4178
Mosquera	36.2%	26.9%	15.8%	20.3%	0.9%	1158
Nariño	30.0%	26.7%	18.4%	24.1%	0.9%	6043
Neiva	31.4%	26.7%	16.7%	24.5%	0.7%	2950
Norte de Santander	29.2%	26.2%	17.2%	26.8%	0.6%	5090
Palmira	33.8%	26.8%	16.1%	22.6%	0.8%	2329
Pasto	35.1%	27.6%	15.1%	21.5%	0.7%	3212
Pereira	31.5%	28.2%	17.6%	22.2%	0.5%	3749
Piedecuesta	33.9%	30.4%	16.0%	18.5%	1.1%	1186
Pitalito	30.7%	27.0%	18.2%	23.5%	0.6%	1067
Popayán	34.2%	28.6%	16.1%	20.3%	0.8%	2459
Putumayo	26.8%	26.4%	19.0%	26.5%	1.3%	2701
Quibdó	23.4%	26.7%	19.2%	27.7%	3.0%	1086
Quindío	28.5%	26.5%	16.9%	27.3%	0.7%	2039
Riohacha	28.3%	26.8%	17.6%	26.3%	1.0%	1341
Rionegro	33.1%	28.4%	16.9%	21.4%	0.4%	1086
Risaralda	26.8%	27.5%	17.4%	27.9%	0.4%	1936
Sabaneta	34.9%	30.0%	18.1%	16.1%	0.8%	496
Sahagún	27.6%	24.7%	20.8%	26.2%	0.7%	1079
San Andrés	30.4%	23.6%	17.8%	28.0%	0.2%	529
Santa Marta	29.5%	27.0%	16.9%	25.4%	1.2%	4355
Santander	31.5%	27.8%	17.2%	23.1%	0.5%	6431

Continúa en la siguiente página



ETC/País	A	B	C	D	Omisión y multimarca	N° estudiantes
Sincelejo	28.0%	26.1%	18.0%	27.4%	0.5%	2696
Soacha	29.8%	26.6%	18.2%	24.5%	0.9%	4802
Sogamoso	34.9%	29.5%	13.5%	22.0%	0.1%	1267
Soledad	32.4%	27.2%	15.8%	23.3%	1.3%	4098
Sucre	25.6%	23.9%	19.8%	30.1%	0.5%	5462
Tolima	25.7%	26.9%	17.8%	28.9%	0.7%	6958
Tuluá	27.3%	27.7%	18.1%	26.4%	0.5%	1832
Tumaco	24.8%	23.9%	17.5%	32.5%	1.2%	1334
Tunja	34.9%	29.7%	16.0%	19.3%	0.2%	1740
Turbo	22.4%	25.1%	21.0%	30.7%	0.8%	1254
Uribe	23.9%	22.2%	19.0%	33.7%	1.3%	306
Valle del Cauca	27.3%	27.0%	17.8%	27.3%	0.6%	6252
Valledupar	28.3%	28.5%	15.3%	27.0%	0.9%	4092
Vichada	22.8%	27.5%	19.1%	30.0%	0.7%	404
Villavicencio	33.1%	28.0%	16.8%	21.3%	0.7%	4110
Yopal	32.3%	29.7%	15.1%	22.8%	0.1%	1395
Yumbo	28.9%	26.4%	19.0%	24.5%	1.2%	894
Zipaquirá	35.8%	24.9%	16.6%	22.4%	0.3%	1155
Colombia	30.7%	27.0%	17.0%	24.4%	0.9%	381884

*Es posible que los porcentajes mostrados no sumen exactamente 100 debido a aproximaciones decimales.

• **Pregunta 29.**

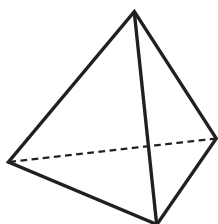

Tetraedro

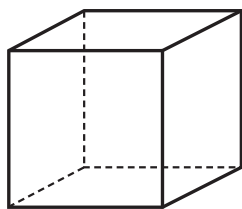

Hexaedro

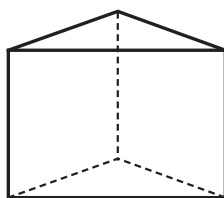

Prisma triangular

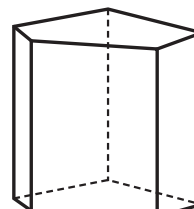

Heptaedro

¿Cuál de los anteriores sólidos tiene igual número de vértices que de caras?

- A. Tetraedro.
- B. Hexaedro.
- C. Prisma triangular.
- D. Heptaedro.

• **Estructura**

Competencia	Comunicación
Componente	Espacial - métrico
Afirmación	Representar y describir propiedades de objetos tridimensionales desde diferentes posiciones y vistas.
Nivel de desempeño	Avanzado
Respuesta Correcta	A

• Resultados a nivel nacional y de Entidad Territorial Certificada (ETC)

ETC/País	A	B	C	D	Omisión y multimarca	N° estudiantes
Amazonas	19.9%	38.1%	21.4%	18.3%	2.2%	627
Antioquia	30.5%	34.3%	20.1%	13.5%	1.6%	19242
Apartadó	29.3%	35.8%	19.0%	14.6%	1.3%	1088
Arauca	28.5%	35.2%	21.9%	13.9%	0.6%	1581
Armenia	33.4%	31.6%	21.3%	12.9%	0.9%	2587
Atlántico	25.7%	35.9%	22.8%	14.4%	1.3%	4931
Barrancabermeja	33.3%	33.0%	19.7%	13.1%	0.9%	1845
Barranquilla	33.2%	33.1%	20.7%	11.9%	1.1%	10592
Bello	36.8%	31.7%	19.2%	11.1%	1.3%	3031
Bogotá, D.C.	40.7%	29.1%	18.4%	11.1%	0.7%	62071
Bolívar	21.0%	38.2%	23.8%	15.5%	1.5%	7541
Boyacá	34.8%	33.5%	18.3%	13.0%	0.5%	7838
Bucaramanga	44.5%	26.8%	17.5%	10.3%	1.0%	4497
Buenaventura	23.6%	39.8%	21.6%	13.8%	1.2%	2787
Buga	35.9%	30.5%	18.4%	14.7%	0.4%	917
Caldas	29.5%	35.0%	20.4%	14.7%	0.5%	4429
Cali	35.3%	30.9%	20.1%	12.7%	1.0%	16580
Caquetá	27.5%	38.3%	19.7%	13.5%	1.1%	1657
Cartagena	27.7%	35.0%	22.6%	13.6%	1.2%	9659
Cartago	34.2%	30.9%	21.7%	12.6%	0.6%	1017
Casanare	29.1%	37.3%	19.7%	13.4%	0.5%	2177
Cauca	25.8%	37.4%	20.5%	15.2%	1.1%	8222
Cesar	24.8%	36.6%	22.4%	15.6%	0.5%	5409
Chocó	21.3%	37.7%	23.9%	15.0%	2.0%	2051
Chía	46.8%	26.7%	15.1%	10.7%	0.7%	1416
Ciénaga	19.8%	38.2%	24.8%	15.8%	1.4%	1060
Cundinamarca	37.1%	32.3%	17.8%	12.2%	0.5%	13372
Córdoba	23.0%	37.8%	22.2%	15.8%	1.3%	8943
Cúcuta	34.3%	33.7%	18.8%	12.2%	1.0%	5733
Dosquebradas	37.8%	29.9%	19.9%	11.8%	0.7%	1319
Duitama	49.0%	25.7%	14.9%	10.2%	0.2%	1251
Envigado	51.6%	22.5%	15.7%	9.6%	0.6%	1633
Facatativá	39.7%	28.7%	19.0%	12.0%	0.5%	1113
Florencia	28.9%	33.8%	21.5%	14.9%	0.8%	1383
Floridablanca	44.1%	28.2%	16.4%	10.4%	0.8%	1982
Fusagasugá	39.1%	32.0%	17.7%	10.5%	0.7%	1119
Girardot	30.0%	33.4%	21.5%	13.7%	1.3%	912

Continúa en la siguiente página

SABER 9 - MATEMÁTICAS

ETC/País	A	B	C	D	Omisión y multimarca	N° estudiantes
Girón	32.9%	32.9%	21.0%	12.7%	0.5%	1109
Guainía	25.1%	36.1%	20.8%	16.9%	1.1%	183
Guaviare	28.3%	35.1%	20.9%	15.0%	0.6%	621
Huila	31.1%	36.2%	18.9%	13.3%	0.6%	5192
Ibagué	34.1%	32.6%	20.3%	12.3%	0.6%	4714
Ipiales	33.3%	36.2%	17.5%	12.4%	0.6%	1066
Itagüí	37.1%	29.9%	19.6%	11.9%	1.5%	1746
Jamundí	28.9%	34.4%	22.3%	13.4%	1.1%	939
La Guajira	25.1%	38.4%	23.6%	12.2%	0.8%	2203
Lorica	21.6%	37.6%	24.5%	15.9%	0.4%	1329
Magangué	23.3%	39.1%	22.0%	14.2%	1.5%	1065
Magdalena	22.1%	37.3%	23.8%	15.3%	1.5%	5904
Maicao	25.5%	36.8%	22.2%	14.9%	0.6%	1178
Malambo	32.1%	32.3%	21.0%	13.2%	1.4%	787
Manizales	33.5%	31.8%	21.0%	12.9%	0.8%	2771
Medellín	36.5%	30.0%	19.8%	12.4%	1.3%	17124
Meta	30.4%	35.8%	19.6%	13.3%	0.9%	3790
Montería	29.8%	33.5%	21.3%	14.5%	0.9%	4178
Mosquera	47.2%	25.0%	16.0%	11.4%	0.4%	1158
Nariño	28.1%	38.5%	19.2%	13.2%	0.9%	6043
Neiva	35.5%	32.7%	19.5%	11.6%	0.7%	2950
Norte de Santander	31.7%	34.3%	19.4%	13.8%	0.8%	5090
Palmira	42.0%	28.4%	17.5%	11.1%	0.9%	2329
Pasto	36.5%	33.7%	17.1%	11.9%	0.7%	3212
Pereira	36.7%	30.6%	19.6%	12.5%	0.6%	3749
Piedecuesta	36.7%	29.0%	20.7%	12.2%	1.3%	1186
Pitalito	39.2%	29.8%	19.7%	10.7%	0.7%	1067
Popayán	36.2%	31.5%	19.3%	12.3%	0.7%	2459
Putumayo	29.3%	38.2%	18.4%	12.8%	1.2%	2701
Quibdó	21.1%	39.5%	22.9%	13.6%	2.9%	1086
Quindío	28.8%	33.8%	21.8%	14.8%	0.7%	2039
Riohacha	28.9%	35.6%	21.2%	13.0%	1.4%	1341
Rionegro	38.9%	30.4%	19.1%	10.9%	0.8%	1086
Risaralda	27.1%	34.1%	22.3%	15.8%	0.7%	1936
Sabaneta	50.2%	25.6%	15.5%	7.7%	1.0%	496
Sahagún	30.7%	33.3%	19.1%	16.4%	0.6%	1079
San Andrés	29.5%	34.2%	22.9%	13.0%	0.4%	529
Santa Marta	26.1%	34.4%	24.2%	13.9%	1.4%	4355
Santander	36.3%	32.0%	18.8%	12.4%	0.5%	6431

Continúa en la siguiente página



ETC/País	A	B	C	D	Omisión y multimarca	N° estudiantes
Sincelejo	28.4%	35.7%	21.6%	13.8%	0.5%	2696
Soacha	33.5%	32.6%	20.6%	12.1%	1.2%	4802
Sogamoso	40.5%	30.5%	17.3%	11.2%	0.5%	1267
Soledad	30.5%	33.7%	22.4%	12.1%	1.2%	4098
Sucre	22.3%	39.5%	22.4%	15.0%	0.8%	5462
Tolima	27.0%	36.5%	21.1%	14.6%	0.8%	6958
Tuluá	35.7%	31.2%	20.5%	11.7%	0.9%	1832
Tumaco	19.9%	38.9%	24.5%	15.1%	1.6%	1334
Tunja	46.5%	26.6%	16.4%	9.9%	0.5%	1740
Turbo	21.3%	35.6%	25.1%	16.7%	1.2%	1254
Uribe	19.6%	42.8%	22.2%	14.7%	0.7%	306
Valle del Cauca	29.0%	34.5%	21.2%	14.7%	0.7%	6252
Valledupar	28.9%	36.0%	22.0%	12.2%	0.9%	4092
Vichada	26.0%	37.1%	20.8%	14.4%	1.7%	404
Villavicencio	36.0%	31.7%	19.6%	12.0%	0.7%	4110
Yopal	37.5%	32.4%	18.6%	11.2%	0.3%	1395
Yumbo	33.7%	31.9%	19.5%	13.9%	1.1%	894
Zipaquirá	43.6%	28.1%	17.0%	11.1%	0.3%	1155
Colombia	33.1%	33.0%	20.1%	12.9%	0.9%	381884

*Es posible que los porcentajes mostrados no sumen exactamente 100 debido a aproximaciones decimales.

• **Pregunta 30.**

La siguiente gráfica presenta información referida al género de película preferido por los estudiantes de un colegio.

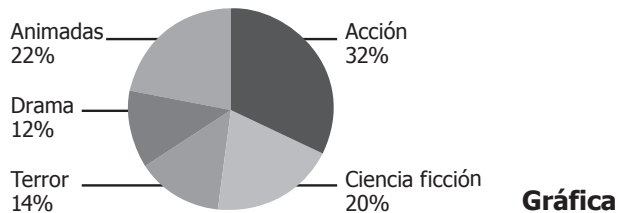

Sesenta y tres estudiantes prefieren las películas de terror. ¿Cuántos prefieren las de ciencia ficción?

- A. 20
- B. 90
- C. 97
- D. 105

• **Estructura**

Competencia	Resolución
Componente	Aleatorio
Afirmación	Resolver y formular problemas a partir de un conjunto de datos presentado en tablas, diagramas de barras y diagrama circular
Nivel de desempeño	Avanzado
Respuesta Correcta	B

• Resultados a nivel nacional y de Entidad Territorial Certificada (ETC)

ETC/País	A	B	C	D	Omisión y multimarca	N° estudiantes
Amazonas	33.7%	26.5%	23.9%	13.2%	2.7%	627
Antioquia	24.8%	31.3%	28.1%	14.0%	1.7%	19242
Apartadó	26.8%	30.1%	27.7%	14.2%	1.2%	1088
Arauca	23.7%	28.3%	30.7%	16.7%	0.6%	1581
Armenia	20.0%	33.2%	31.1%	14.4%	1.3%	2587
Atlántico	31.1%	28.8%	24.9%	13.4%	1.7%	4931
Barrancabermeja	23.4%	33.8%	26.7%	14.9%	1.3%	1845
Barranquilla	22.5%	33.5%	28.7%	14.1%	1.3%	10592
Bello	17.8%	36.3%	30.2%	14.1%	1.6%	3031
Bogotá, D.C.	15.3%	39.3%	30.5%	14.0%	0.9%	62071
Bolívar	35.7%	25.7%	22.8%	13.8%	1.9%	7541
Boyacá	20.6%	34.5%	29.2%	15.2%	0.6%	7838
Bucaramanga	14.1%	38.9%	30.5%	15.5%	1.0%	4497
Buenaventura	34.6%	27.2%	23.8%	12.4%	2.1%	2787
Buga	18.2%	36.1%	30.4%	14.8%	0.4%	917
Caldas	26.6%	32.3%	26.3%	14.1%	0.7%	4429
Cali	20.5%	36.0%	28.2%	14.1%	1.3%	16580
Caquetá	30.8%	29.8%	23.7%	14.6%	1.1%	1657
Cartagena	27.0%	31.4%	26.6%	13.7%	1.3%	9659
Cartago	20.7%	33.7%	31.1%	13.6%	0.9%	1017
Casanare	22.5%	32.9%	29.6%	14.5%	0.5%	2177
Cauca	34.3%	29.8%	21.9%	12.6%	1.4%	8222
Cesar	32.2%	28.3%	26.1%	12.8%	0.6%	5409
Chocó	37.4%	26.5%	21.1%	13.0%	2.0%	2051
Chía	12.4%	42.7%	32.2%	11.9%	0.8%	1416
Ciénaga	37.2%	23.9%	23.2%	13.9%	1.9%	1060
Cundinamarca	18.7%	35.6%	29.9%	14.9%	0.9%	13372
Córdoba	33.8%	27.2%	24.1%	13.7%	1.2%	8943
Cúcuta	20.6%	33.8%	28.8%	15.8%	1.0%	5733
Dosquebradas	17.1%	35.9%	30.7%	15.5%	0.7%	1319
Duitama	9.9%	42.0%	32.6%	15.0%	0.4%	1251
Envigado	11.7%	44.3%	30.4%	13.0%	0.5%	1633
Facatativá	15.6%	38.6%	33.1%	12.0%	0.6%	1113
Florencia	25.1%	31.6%	27.8%	14.5%	1.0%	1383
Floridablanca	13.8%	41.6%	29.4%	14.1%	1.1%	1982
Fusagasugá	15.5%	35.7%	31.3%	16.4%	1.2%	1119
Girardot	26.6%	30.2%	29.5%	12.9%	0.8%	912

Continúa en la siguiente página

SABER 9 - MATEMÁTICAS

ETC/País	A	B	C	D	Omisión y multimarca	N° estudiantes
Girón	18.3%	32.0%	32.5%	16.6%	0.6%	1109
Guainía	27.3%	31.7%	26.8%	13.7%	0.5%	183
Guaviare	26.2%	28.8%	29.6%	14.5%	0.8%	621
Huila	25.8%	31.5%	27.0%	14.9%	0.9%	5192
Ibagué	19.8%	33.4%	31.6%	14.2%	1.0%	4714
Ipiales	20.4%	33.5%	30.1%	15.3%	0.8%	1066
Itagüí	18.9%	37.5%	28.6%	13.7%	1.3%	1746
Jamundí	24.6%	33.8%	27.9%	12.9%	0.9%	939
La Guajira	32.5%	27.2%	24.9%	14.3%	1.1%	2203
Lorica	33.2%	28.1%	23.5%	14.0%	1.2%	1329
Magangué	33.5%	28.1%	24.2%	12.5%	1.7%	1065
Magdalena	36.2%	25.4%	22.6%	13.9%	1.9%	5904
Maicao	33.4%	26.2%	25.0%	14.7%	0.8%	1178
Malambo	29.4%	34.9%	24.1%	10.2%	1.4%	787
Manizales	19.7%	35.8%	29.8%	14.0%	0.8%	2771
Medellín	18.6%	35.4%	30.1%	14.3%	1.6%	17124
Meta	23.3%	31.9%	28.0%	15.7%	1.1%	3790
Montería	27.1%	30.9%	25.4%	15.2%	1.4%	4178
Mosquera	12.8%	40.3%	31.6%	14.8%	0.5%	1158
Nariño	26.4%	32.9%	25.5%	14.1%	1.1%	6043
Neiva	19.5%	35.7%	29.3%	14.7%	0.9%	2950
Norte de Santander	24.0%	32.4%	28.3%	14.6%	0.7%	5090
Palmira	19.1%	37.2%	28.0%	14.4%	1.3%	2329
Pasto	18.4%	38.3%	27.0%	15.3%	1.0%	3212
Pereira	17.1%	38.3%	29.0%	15.0%	0.5%	3749
Piedecuesta	14.2%	35.2%	33.1%	16.2%	1.3%	1186
Pitalito	18.6%	34.3%	27.8%	18.7%	0.6%	1067
Popayán	19.1%	34.0%	30.5%	15.0%	1.3%	2459
Putumayo	24.3%	30.4%	27.8%	15.9%	1.6%	2701
Quibdó	34.7%	26.2%	23.2%	12.7%	3.2%	1086
Quindío	24.3%	31.5%	29.1%	14.3%	0.8%	2039
Riohacha	28.9%	27.8%	27.1%	15.1%	1.2%	1341
Rionegro	15.6%	41.0%	29.1%	13.8%	0.6%	1086
Risaralda	27.2%	31.9%	25.5%	14.7%	0.6%	1936
Sabaneta	11.9%	42.5%	32.1%	12.5%	1.0%	496
Sahagún	29.7%	28.3%	26.4%	14.8%	0.8%	1079
San Andrés	25.7%	31.2%	28.4%	14.0%	0.8%	529
Santa Marta	27.1%	30.4%	25.9%	14.6%	1.9%	4355
Santander	19.2%	35.0%	29.8%	15.2%	0.8%	6431

Continúa en la siguiente página



ETC/País	A	B	C	D	Omisión y multimarca	N° estudiantes
Sincelejo	27.5%	31.3%	26.1%	14.2%	0.9%	2696
Soacha	20.4%	35.3%	28.8%	14.2%	1.2%	4802
Sogamoso	13.1%	39.8%	32.9%	13.7%	0.6%	1267
Soledad	24.2%	33.6%	27.6%	13.4%	1.2%	4098
Sucre	35.7%	25.0%	23.6%	14.3%	1.3%	5462
Tolima	31.0%	28.0%	25.4%	14.8%	0.9%	6958
Tuluá	23.2%	32.7%	28.7%	14.6%	0.8%	1832
Tumaco	38.2%	24.4%	21.1%	14.4%	1.9%	1334
Tunja	11.6%	40.6%	32.4%	15.0%	0.3%	1740
Turbo	38.0%	24.0%	23.8%	13.1%	1.2%	1254
Uribe	42.2%	19.9%	23.9%	13.7%	0.3%	306
Valle del Cauca	26.9%	31.7%	26.7%	13.8%	0.9%	6252
Valledupar	28.5%	31.6%	25.2%	13.6%	1.2%	4092
Vichada	32.7%	28.2%	25.7%	11.6%	1.7%	404
Villavicencio	18.0%	37.5%	29.4%	14.2%	0.8%	4110
Yopal	14.8%	37.2%	31.5%	16.1%	0.4%	1395
Yumbo	23.8%	35.7%	23.5%	14.9%	2.1%	894
Zipaquirá	13.2%	42.3%	31.2%	12.7%	0.7%	1155
Colombia	22.9%	33.7%	28.0%	14.2%	1.1%	381884

*Es posible que los porcentajes mostrados no sumen exactamente 100 debido a aproximaciones decimales.

• **Pregunta 31.**

La figura representa la disposición de las sillas de algunas de las 7 primeras filas de un auditorio. En la figura falta la información de las filas 4 y 5.

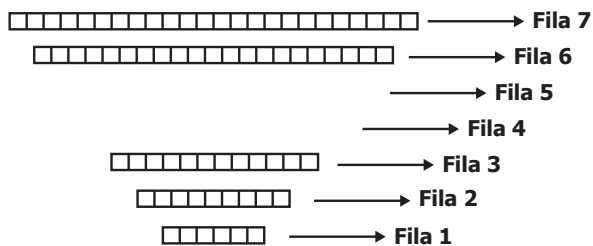

Escenario

Figura

La disposición de las sillas determina una secuencia. ¿Cuántas sillas en total hay en las filas 4 y 5?

- A. 9
- B. 26
- C. 33
- D. 72

• **Estructura**

Competencia	Comunicación
Componente	Numérico - variacional
Afirmación	Reconocer reglas de formación de términos en una sucesión, a partir de la anterior (adición y producto).
Nivel de desempeño	Mínimo
Respuesta Correcta	C

• **Resultados a nivel nacional y de Entidad Territorial Certificada (ETC)**

ETC/País	A	B	C	D	Omisión y multimarca	N° estudiantes
Amazonas	8.9%	19.0%	60.6%	8.5%	3.0%	627
Antioquia	7.1%	17.1%	68.2%	6.0%	1.5%	19242
Apartadó	9.5%	18.1%	63.1%	7.8%	1.6%	1088
Arauca	4.6%	13.2%	76.2%	5.6%	0.4%	1581
Armenia	5.5%	16.5%	70.8%	6.2%	0.9%	2587
Atlántico	10.2%	19.7%	60.2%	8.6%	1.4%	4931
Barrancabermeja	5.6%	18.1%	70.0%	5.5%	0.8%	1845
Barranquilla	6.4%	17.1%	69.2%	6.3%	1.0%	10592
Bello	5.7%	16.8%	71.4%	5.0%	1.2%	3031
Bogotá, D.C.	3.4%	13.2%	78.9%	3.9%	0.6%	62071
Bolívar	12.1%	20.3%	57.2%	8.8%	1.7%	7541
Boyacá	4.1%	13.0%	78.9%	3.5%	0.5%	7838
Bucaramanga	3.8%	11.8%	79.9%	3.8%	0.7%	4497
Buenaventura	10.3%	19.7%	60.0%	7.8%	2.1%	2787
Buga	5.7%	17.4%	71.3%	4.8%	0.8%	917
Caldas	5.8%	17.6%	70.3%	5.7%	0.5%	4429
Cali	5.8%	16.7%	71.2%	5.5%	0.8%	16580
Caquetá	7.2%	17.7%	67.4%	6.6%	1.1%	1657
Cartagena	8.8%	19.8%	62.9%	7.3%	1.1%	9659
Cartago	4.6%	18.0%	72.2%	4.6%	0.6%	1017
Casanare	4.6%	14.2%	76.1%	4.8%	0.3%	2177
Cauca	8.2%	17.9%	66.3%	6.5%	1.2%	8222
Cesar	9.3%	18.8%	63.9%	7.5%	0.5%	5409
Chocó	13.8%	19.0%	54.9%	10.4%	1.9%	2051
Chía	1.1%	10.2%	85.3%	3.0%	0.4%	1416
Ciénaga	11.9%	22.8%	54.2%	9.3%	1.7%	1060
Cundinamarca	3.3%	14.6%	77.8%	3.8%	0.6%	13372
Córdoba	9.8%	20.8%	59.3%	8.8%	1.3%	8943
Cúcuta	5.2%	15.3%	74.5%	4.1%	0.9%	5733
Dosquebradas	4.2%	13.2%	76.2%	5.8%	0.6%	1319
Duitama	2.1%	12.1%	83.1%	2.7%	0.1%	1251
Envigado	4.8%	12.5%	78.6%	3.7%	0.4%	1633
Facatativá	2.4%	11.6%	83.1%	2.6%	0.3%	1113
Florencia	4.4%	15.7%	74.8%	4.6%	0.6%	1383
Floridablanca	4.1%	11.2%	79.9%	3.9%	0.9%	1982
Fusagasugá	3.1%	13.4%	79.3%	3.6%	0.6%	1119
Girardot	6.7%	21.6%	63.9%	6.8%	1.0%	912

Continúa en la siguiente página

SABER 9 - MATEMÁTICAS

ETC/País	A	B	C	D	Omisión y multimarca	N° estudiantes
Girón	3.3%	13.6%	77.5%	5.3%	0.2%	1109
Guainía	9.3%	15.3%	67.2%	6.6%	1.6%	183
Guaviare	5.6%	17.4%	69.2%	6.8%	1.0%	621
Huila	5.0%	16.1%	73.7%	4.5%	0.6%	5192
Ibagué	4.7%	14.8%	74.7%	5.3%	0.6%	4714
Ipiales	4.0%	12.6%	80.0%	3.2%	0.2%	1066
Itagüí	7.6%	18.5%	64.9%	7.3%	1.6%	1746
Jamundí	5.3%	17.9%	69.8%	6.1%	1.0%	939
La Guajira	10.3%	19.7%	58.9%	10.2%	0.9%	2203
Lorica	11.6%	24.0%	54.0%	9.6%	0.8%	1329
Magangué	9.4%	20.8%	62.0%	6.4%	1.4%	1065
Magdalena	10.7%	22.4%	56.4%	9.0%	1.5%	5904
Maicao	12.7%	20.4%	58.6%	7.7%	0.6%	1178
Malambo	7.9%	17.9%	65.7%	7.1%	1.4%	787
Manizales	5.0%	14.7%	74.1%	5.5%	0.7%	2771
Medellín	6.0%	16.5%	69.8%	6.3%	1.4%	17124
Meta	5.5%	17.2%	70.4%	6.0%	0.9%	3790
Montería	8.8%	18.8%	64.9%	6.4%	1.1%	4178
Mosquera	2.9%	11.4%	81.4%	3.8%	0.4%	1158
Nariño	5.5%	14.6%	74.5%	4.4%	1.0%	6043
Neiva	4.0%	13.6%	77.6%	4.0%	0.8%	2950
Norte de Santander	5.0%	14.9%	74.3%	5.0%	0.8%	5090
Palmira	3.3%	14.3%	77.4%	4.4%	0.6%	2329
Pasto	3.8%	12.7%	79.8%	3.2%	0.6%	3212
Pereira	3.6%	15.5%	75.5%	4.9%	0.5%	3749
Piedecuesta	3.7%	12.9%	78.2%	4.0%	1.2%	1186
Pitalito	4.0%	13.3%	76.9%	4.8%	0.9%	1067
Popayán	5.0%	14.4%	76.5%	3.5%	0.7%	2459
Putumayo	5.2%	15.9%	73.9%	4.0%	1.0%	2701
Quibdó	11.3%	18.5%	57.7%	9.2%	3.2%	1086
Quindío	6.9%	19.7%	66.7%	6.0%	0.7%	2039
Riohacha	8.5%	18.4%	64.4%	7.3%	1.4%	1341
Rionegro	3.1%	15.2%	77.4%	3.9%	0.4%	1086
Risaralda	6.6%	18.9%	69.1%	4.8%	0.7%	1936
Sabaneta	4.2%	9.9%	80.2%	4.8%	0.8%	496
Sahagún	9.2%	16.6%	66.5%	6.7%	1.0%	1079
San Andrés	9.1%	22.5%	57.7%	9.6%	1.1%	529
Santa Marta	8.0%	19.7%	63.3%	7.7%	1.3%	4355
Santander	4.0%	13.5%	77.8%	4.1%	0.5%	6431

Continúa en la siguiente página



ETC/País	A	B	C	D	Omisión y multimarca	N° estudiantes
Sincelejo	9.2%	18.8%	64.2%	6.9%	0.8%	2696
Soacha	4.0%	15.1%	74.6%	5.2%	1.0%	4802
Sogamoso	2.4%	11.8%	82.4%	3.2%	0.1%	1267
Soledad	6.8%	16.8%	67.8%	7.1%	1.5%	4098
Sucre	11.0%	21.0%	58.8%	8.2%	1.0%	5462
Tolima	7.1%	18.0%	68.6%	5.6%	0.7%	6958
Tuluá	5.5%	16.6%	72.1%	4.9%	0.9%	1832
Tumaco	13.1%	20.6%	55.0%	9.5%	1.7%	1334
Tunja	3.3%	11.2%	82.4%	2.8%	0.3%	1740
Turbo	10.0%	21.5%	58.1%	9.2%	1.3%	1254
Uribe	9.8%	20.9%	60.8%	8.2%	0.3%	306
Valle del Cauca	6.3%	19.2%	67.7%	6.1%	0.6%	6252
Valledupar	7.4%	17.7%	67.9%	6.3%	0.7%	4092
Vichada	8.4%	13.6%	69.8%	6.4%	1.7%	404
Villavicencio	4.2%	13.2%	77.4%	4.5%	0.6%	4110
Yopal	3.7%	11.9%	81.1%	2.9%	0.3%	1395
Yumbo	6.0%	16.6%	69.7%	6.7%	1.0%	894
Zipaquirá	2.1%	11.6%	82.9%	3.1%	0.3%	1155
Colombia	6.0%	16.2%	71.3%	5.6%	0.9%	381884

*Es posible que los porcentajes mostrados no sumen exactamente 100 debido a aproximaciones decimales.

• Pregunta 32.

En nuestro planeta, la superficie ocupada por los océanos es de aproximadamente $3,6 \times 10^{14} \text{ m}^2$ y su profundidad promedio es de $3,7 \times 10^3 \text{ m}$.

$$\text{volumen} = \text{área superficie} \times \text{altura}$$

¿Cuál de las siguientes expresiones representa el volumen aproximado, en m^3 , de agua oceánica en el planeta?

- A. $(3,6 \times 3,7) \times 10^3$
- B. $(3,6 \times 3,7) \times 10^6$
- C. $(3,6 \times 3,7) \times 10^{17}$
- D. $(3,6 \times 3,7) \times 10^{42}$

• Estructura

Competencia	Resolución
Componente	Numérico - variacional
Afirmación	Utilizar propiedades y relaciones de los números reales para resolver problemas.
Nivel de desempeño	Avanzado
Respuesta Correcta	C

• Resultados a nivel nacional y de Entidad Territorial Certificada (ETC)

ETC/País	A	B	C	D	Omisión y multimarca	N° estudiantes
Amazonas	34.4%	19.3%	27.1%	14.7%	4.5%	627
Antioquia	29.2%	19.7%	34.7%	14.5%	1.9%	19242
Apartadó	25.8%	21.1%	33.4%	17.7%	1.9%	1088
Arauca	31.3%	17.7%	35.8%	14.6%	0.6%	1581
Armenia	27.3%	19.1%	37.5%	14.9%	1.2%	2587
Atlántico	30.9%	19.1%	32.4%	16.1%	1.5%	4931
Barrancabermeja	26.2%	18.3%	39.6%	14.6%	1.4%	1845
Barranquilla	25.9%	18.4%	41.0%	13.2%	1.5%	10592
Bello	27.3%	18.5%	38.8%	13.4%	2.0%	3031
Bogotá, D.C.	24.5%	17.3%	44.5%	12.6%	1.1%	62071
Bolívar	29.9%	19.9%	32.4%	16.0%	1.8%	7541
Boyacá	29.9%	17.0%	40.0%	12.4%	0.7%	7838
Bucaramanga	23.7%	15.9%	46.8%	12.4%	1.3%	4497
Buenaventura	28.0%	18.6%	35.3%	15.7%	2.4%	2787
Buga	24.9%	16.8%	43.6%	13.5%	1.2%	917

Continúa en la siguiente página



ETC/País	A	B	C	D	Omisión y multimarca	N° estudiantes
Caldas	31.6%	19.1%	34.5%	14.0%	0.7%	4429
Cali	25.8%	18.5%	41.0%	13.3%	1.4%	16580
Caquetá	32.3%	19.6%	33.2%	13.8%	1.1%	1657
Cartagena	27.1%	19.0%	37.3%	15.1%	1.5%	9659
Cartago	27.7%	18.4%	38.5%	13.9%	1.5%	1017
Casanare	31.2%	19.8%	36.0%	12.2%	0.7%	2177
Cauca	32.6%	19.4%	32.8%	13.6%	1.6%	8222
Cesar	30.1%	20.2%	33.8%	15.2%	0.7%	5409
Chocó	28.7%	19.1%	32.4%	17.6%	2.1%	2051
Chía	20.9%	13.9%	51.6%	12.8%	0.8%	1416
Ciénaga	32.1%	19.6%	30.4%	15.9%	2.0%	1060
Cundinamarca	28.5%	16.5%	41.7%	12.4%	0.9%	13372
Córdoba	30.9%	19.9%	31.0%	16.5%	1.7%	8943
Cúcuta	25.3%	16.2%	44.5%	12.7%	1.3%	5733
Dosquebradas	26.9%	20.8%	40.1%	11.7%	0.5%	1319
Duitama	21.3%	15.4%	51.4%	11.4%	0.6%	1251
Envigado	20.5%	17.0%	47.2%	14.5%	0.9%	1633
Facatativá	24.4%	14.0%	48.1%	12.8%	0.7%	1113
Florencia	28.7%	17.5%	39.8%	12.9%	1.1%	1383
Floridablanca	22.7%	14.6%	51.3%	10.2%	1.2%	1982
Fusagasugá	28.8%	19.0%	39.0%	11.8%	1.4%	1119
Girardot	30.9%	20.8%	32.3%	14.4%	1.5%	912
Girón	28.2%	17.9%	38.8%	14.6%	0.5%	1109
Guainía	31.1%	18.6%	37.2%	12.6%	0.5%	183
Guaviare	36.1%	18.0%	31.6%	13.0%	1.3%	621
Huila	30.9%	18.5%	37.3%	12.3%	1.0%	5192
Ibagué	27.4%	18.1%	39.9%	13.6%	1.0%	4714
Ipiales	30.0%	15.5%	43.1%	10.6%	0.8%	1066
Itagüí	27.0%	19.0%	35.6%	16.8%	1.7%	1746
Jamundí	28.4%	18.8%	38.0%	13.5%	1.2%	939
La Guajira	30.6%	20.7%	31.7%	15.9%	1.0%	2203
Lórica	31.7%	20.9%	28.3%	18.3%	0.8%	1329
Magangué	33.9%	16.7%	31.5%	16.2%	1.7%	1065
Magdalena	30.0%	20.7%	31.8%	15.7%	1.8%	5904
Maicao	30.9%	17.8%	35.1%	15.2%	1.0%	1178
Malambo	25.4%	16.0%	43.3%	13.2%	2.0%	787
Manizales	26.9%	19.1%	40.2%	13.1%	0.8%	2771
Medellín	26.3%	19.6%	37.4%	14.7%	1.9%	17124
Meta	31.5%	19.6%	34.9%	13.0%	1.1%	3790
Montería	26.7%	18.4%	38.2%	15.3%	1.4%	4178

Continúa en la siguiente página

SABER 9 - MATEMÁTICAS

ETC/País	A	B	C	D	Omisión y multimarca	Nº estudiantes
Mosquera	26.8%	16.1%	43.6%	12.6%	0.9%	1158
Nariño	30.1%	16.5%	39.9%	12.2%	1.3%	6043
Neiva	26.1%	17.1%	44.6%	11.0%	1.2%	2950
Norte de Santander	27.7%	17.4%	39.9%	14.0%	0.9%	5090
Palmira	24.5%	15.5%	47.5%	11.1%	1.4%	2329
Pasto	25.2%	17.0%	45.0%	11.7%	1.1%	3212
Pereira	26.8%	17.7%	42.4%	12.3%	0.8%	3749
Piedecuesta	24.6%	19.1%	42.8%	11.8%	1.7%	1186
Pitalito	28.5%	15.3%	42.5%	12.8%	0.9%	1067
Popayán	27.2%	15.9%	42.6%	12.8%	1.4%	2459
Putumayo	29.7%	19.0%	37.7%	12.0%	1.6%	2701
Quibdó	27.2%	20.1%	32.5%	16.6%	3.7%	1086
Quindío	31.1%	20.6%	33.6%	13.6%	1.0%	2039
Riohacha	29.4%	19.8%	35.2%	13.6%	1.9%	1341
Rionegro	25.2%	17.8%	43.2%	12.7%	1.1%	1086
Risaralda	30.9%	18.5%	35.2%	14.5%	0.9%	1936
Sabaneta	22.2%	17.7%	47.2%	11.7%	1.2%	496
Sahagún	27.7%	21.0%	34.2%	15.7%	1.4%	1079
San Andrés	24.4%	22.7%	33.3%	18.3%	1.3%	529
Santa Marta	27.4%	19.8%	35.3%	15.7%	1.8%	4355
Santander	27.8%	16.3%	41.7%	13.5%	0.8%	6431
Sincelejo	29.4%	18.1%	35.8%	15.8%	0.9%	2696
Soacha	28.5%	18.5%	38.7%	13.1%	1.3%	4802
Sogamoso	25.0%	14.4%	49.1%	10.9%	0.6%	1267
Soledad	26.7%	19.0%	38.0%	14.5%	1.7%	4098
Sucre	31.3%	19.5%	32.8%	15.3%	1.1%	5462
Tolima	30.6%	19.4%	35.2%	13.7%	1.2%	6958
Tuluá	29.0%	18.6%	36.9%	14.5%	1.0%	1832
Tumaco	29.5%	18.1%	31.5%	18.6%	2.2%	1334
Tunja	23.4%	14.9%	49.4%	11.7%	0.5%	1740
Turbo	31.6%	21.5%	31.2%	13.8%	1.9%	1254
Uribe	37.9%	18.3%	25.8%	17.6%	0.3%	306
Valle del Cauca	30.9%	18.5%	35.6%	14.0%	1.0%	6252
Valledupar	27.2%	18.5%	38.0%	15.2%	1.1%	4092
Vichada	34.7%	19.1%	29.5%	14.6%	2.2%	404
Villavicencio	25.4%	18.2%	42.2%	13.2%	1.0%	4110
Yopal	27.1%	18.6%	40.7%	13.2%	0.4%	1395
Yumbo	28.7%	17.4%	40.0%	11.9%	1.9%	894
Zipaquirá	26.7%	13.0%	48.0%	11.5%	0.9%	1155
Colombia	27.6%	18.3%	39.1%	13.7%	1.3%	381884

*Es posible que los porcentajes mostrados no sumen exactamente 100 debido a aproximaciones decimales.

• **Pregunta 33.**

Un turista pagó un total de 180 dólares en un hotel. La cuenta incluye el costo de tres noches de hospedaje y 75 dólares de alimentación.

El siguiente procedimiento permite determinar cuántos dólares pagó el turista, por cada noche de hospedaje.

$$\begin{aligned} 3x + 75 &= 180 \\ 3x + 75 - 75 &= 180 - 75 \\ 3x &= 105 \\ \boxed{} \\ x &= 35 \end{aligned}$$

¿Cuál de los siguientes pasos completa correctamente el procedimiento?

- A. $3x - 3 = 105 - 3$
- B. $3x + 3 = 105 + 3$
- C. $3.(3x) = (3).105$
- D. $\frac{3x}{3} = \frac{105}{3}$

• **Estructura**

Competencia	Razonamiento
Componente	Numérico - variacional
Afirmación	Interpretar y usar expresiones algebraicas equivalentes.
Nivel de desempeño	Satisfactorio
Respuesta Correcta	D

• Resultados a nivel nacional y de Entidad Territorial Certificada (ETC)

ETC/País	A	B	C	D	Omisión y multimarca	N° estudiantes
Amazonas	17.5%	20.4%	20.9%	38.1%	3.0%	627
Antioquia	17.1%	21.5%	17.7%	42.1%	1.6%	19242
Apartadó	18.8%	25.2%	15.7%	38.6%	1.7%	1088
Arauca	16.6%	19.0%	16.3%	47.6%	0.4%	1581
Armenia	18.3%	20.8%	15.6%	44.6%	0.8%	2587
Atlántico	18.9%	22.4%	18.1%	39.3%	1.3%	4931
Barrancabermeja	20.5%	20.3%	15.8%	42.9%	0.5%	1845
Barranquilla	17.9%	19.1%	14.6%	47.4%	1.0%	10592
Bello	19.0%	20.6%	15.4%	43.5%	1.5%	3031
Bogotá, D.C.	14.8%	16.5%	12.5%	55.3%	0.9%	62071
Bolívar	18.6%	22.7%	21.3%	36.1%	1.4%	7541
Boyacá	14.7%	17.1%	15.7%	52.0%	0.4%	7838
Bucaramanga	13.3%	14.6%	11.6%	59.5%	0.9%	4497
Buenaventura	19.9%	22.4%	21.6%	34.6%	1.4%	2787
Buga	16.9%	19.6%	15.2%	47.5%	0.8%	917
Caldas	15.9%	21.5%	18.7%	43.1%	0.7%	4429
Cali	18.4%	18.4%	14.3%	47.7%	1.2%	16580
Caquetá	15.7%	20.9%	18.6%	44.2%	0.5%	1657
Cartagena	21.4%	21.0%	17.0%	39.5%	1.1%	9659
Cartago	14.7%	17.0%	14.4%	52.7%	1.2%	1017
Casanare	15.9%	19.2%	14.9%	49.3%	0.6%	2177
Cauca	14.9%	19.3%	18.6%	46.0%	1.2%	8222
Cesar	18.8%	20.9%	19.6%	40.2%	0.5%	5409
Chocó	17.5%	23.9%	21.2%	36.0%	1.4%	2051
Chía	12.5%	13.4%	9.4%	63.9%	0.8%	1416
Ciénaga	20.6%	25.1%	19.9%	33.3%	1.1%	1060
Cundinamarca	14.2%	17.1%	14.4%	53.6%	0.7%	13372
Córdoba	17.0%	22.9%	21.2%	37.8%	1.1%	8943
Cúcuta	15.4%	17.5%	15.9%	50.3%	0.9%	5733
Dosquebradas	14.6%	17.6%	13.7%	53.4%	0.6%	1319
Duitama	13.8%	14.4%	9.6%	62.0%	0.2%	1251
Envigado	14.5%	16.2%	10.7%	57.9%	0.7%	1633
Facatativá	12.6%	14.5%	10.1%	62.2%	0.7%	1113
Florencia	16.7%	20.7%	14.5%	47.2%	0.9%	1383
Floridablanca	11.6%	14.1%	11.1%	62.4%	0.9%	1982
Fusagasugá	15.7%	18.1%	14.1%	51.4%	0.6%	1119
Girardot	19.2%	21.2%	18.0%	40.8%	0.9%	912

Continúa en la siguiente página



ETC/País	A	B	C	D	Omisión y multimarca	N° estudiantes
Girón	19.3%	18.1%	15.2%	47.2%	0.2%	1109
Guainía	6.6%	16.9%	13.7%	62.8%	0.0%	183
Guaviare	16.6%	21.9%	17.9%	42.8%	0.8%	621
Huila	15.0%	20.2%	15.4%	48.7%	0.6%	5192
Ibagué	15.1%	16.5%	14.0%	53.6%	0.8%	4714
Ipiales	13.5%	14.1%	11.6%	60.1%	0.7%	1066
Itagüí	22.9%	20.9%	17.8%	37.0%	1.4%	1746
Jamundí	17.0%	17.7%	17.4%	47.2%	0.7%	939
La Guajira	18.8%	20.7%	21.3%	38.3%	0.9%	2203
Lorica	16.3%	24.0%	22.6%	36.6%	0.5%	1329
Magangué	17.7%	19.0%	20.3%	41.7%	1.4%	1065
Magdalena	18.8%	22.7%	21.3%	35.7%	1.6%	5904
Maicao	20.1%	22.1%	20.0%	37.1%	0.7%	1178
Malambo	20.6%	20.7%	17.0%	40.7%	1.0%	787
Manizales	16.2%	17.3%	15.6%	50.1%	0.8%	2771
Medellín	18.5%	19.7%	14.9%	45.3%	1.6%	17124
Meta	17.4%	21.4%	17.9%	42.3%	0.9%	3790
Montería	18.8%	19.4%	17.7%	43.2%	0.9%	4178
Mosquera	13.4%	14.4%	12.7%	59.1%	0.4%	1158
Nariño	11.7%	15.8%	14.1%	57.4%	1.0%	6043
Neiva	15.8%	16.0%	14.1%	53.3%	0.8%	2950
Norte de Santander	15.0%	18.1%	15.5%	50.8%	0.6%	5090
Palmira	14.7%	15.5%	13.1%	55.6%	1.0%	2329
Pasto	12.8%	14.4%	10.9%	61.3%	0.6%	3212
Pereira	15.8%	18.4%	14.5%	50.4%	0.8%	3749
Piedecuesta	15.4%	15.3%	12.9%	54.8%	1.5%	1186
Pitalito	11.2%	13.4%	16.0%	58.5%	0.9%	1067
Popayán	12.8%	14.2%	10.3%	61.9%	0.8%	2459
Putumayo	11.8%	17.3%	16.0%	53.4%	1.4%	2701
Quibdó	20.1%	25.5%	20.6%	30.5%	3.3%	1086
Quindío	17.0%	23.0%	17.8%	41.5%	0.7%	2039
Riohacha	18.6%	21.6%	15.8%	42.8%	1.2%	1341
Rionegro	14.5%	18.8%	12.8%	53.1%	0.8%	1086
Risaralda	15.8%	21.2%	19.0%	43.4%	0.6%	1936
Sabaneta	14.1%	15.1%	13.5%	56.7%	0.6%	496
Sahagún	17.4%	20.7%	19.3%	42.0%	0.6%	1079
San Andrés	21.2%	25.0%	15.7%	37.2%	0.9%	529
Santa Marta	19.7%	21.9%	17.7%	39.1%	1.5%	4355
Santander	13.9%	16.3%	14.4%	54.8%	0.5%	6431

Continúa en la siguiente página

ETC/País	A	B	C	D	Omisión y multimarca	N° estudiantes
Sincelejo	22.0%	19.2%	17.8%	40.2%	0.8%	2696
Soacha	19.0%	19.7%	15.5%	44.6%	1.2%	4802
Sogamoso	13.5%	13.0%	12.2%	61.2%	0.2%	1267
Soledad	20.0%	18.2%	16.0%	44.6%	1.3%	4098
Sucre	17.5%	21.4%	20.7%	39.6%	0.8%	5462
Tolima	16.3%	20.5%	18.0%	44.5%	0.8%	6958
Tuluá	17.8%	20.1%	14.5%	46.5%	1.1%	1832
Tumaco	19.6%	20.9%	20.8%	36.7%	1.9%	1334
Tunja	12.6%	14.1%	11.0%	62.1%	0.2%	1740
Turbo	18.8%	26.1%	19.1%	34.8%	1.2%	1254
Uribe	10.8%	26.5%	21.9%	40.2%	0.7%	306
Valle del Cauca	17.5%	21.4%	17.1%	43.1%	0.9%	6252
Valledupar	17.7%	18.0%	17.9%	45.6%	0.8%	4092
Vichada	16.3%	19.3%	17.8%	45.0%	1.5%	404
Villavicencio	17.0%	17.9%	14.3%	49.9%	0.9%	4110
Yopal	16.0%	16.6%	14.0%	53.1%	0.4%	1395
Yumbo	17.2%	19.8%	13.9%	47.5%	1.6%	894
Zipaquirá	12.6%	12.4%	12.2%	62.2%	0.6%	1155
Colombia	16.5%	18.9%	15.7%	47.9%	1.0%	381884

*Es posible que los porcentajes mostrados no sumen exactamente 100 debido a aproximaciones decimales.

• **Pregunta 34.**

El siguiente aviso se encuentra en la entrada de un parque deportivo.

CANCHA DE MICROFÚTBOL	
Alquiler por partido	\$60.000
Servicio de ducha por persona	\$2.000

La expresión que permite determinar el valor que debe pagar un grupo por el alquiler de la cancha de microfútbol, para un partido, dependiendo del número de jugadores que utilice la ducha es $a = 2.000j + 60.000$, donde a representa el valor a pagar y j el número de jugadores que usan el servicio de ducha.

¿En cuál de las siguientes tablas se representa correctamente la relación entre el costo por pagar y el número de jugadores que utilizan la ducha?

A.

No j de jugadores que usan la ducha	Valor a por pagar (\$)
0	62.000
1	62.000
2	62.000
3	62.000
4	62.000
5	62.000

B.

No j de jugadores que usan la ducha	Valor a por pagar (\$)
0	60.000
1	62.000
2	64.000
3	66.000
4	68.000
5	70.000

C.

No j de jugadores que usan la ducha	Valor a por pagar (\$)
0	2.000
1	62.000
2	122.000
3	182.000
4	242.000
5	302.000

D.

No j de jugadores que usan la ducha	Valor a por pagar (\$)
0	0
1	62.000
2	124.000
3	186.000
4	248.000
5	400.000

• **Estructura**

Competencia	Comunicación
Componente	Numérico - variacional
Afirmación	Usar y relacionar diferentes representaciones para modelar situaciones de variación.
Nivel de desempeño	Satisfactorio
Respuesta Correcta	B

• Resultados a nivel nacional y de Entidad Territorial Certificada (ETC)

ETC/País	A	B	C	D	Omisión y multimarca	N° estudiantes
Amazonas	20.6%	35.7%	17.2%	22.0%	4.5%	627
Antioquia	16.8%	42.6%	15.2%	23.6%	1.8%	19242
Apartadó	20.9%	36.9%	19.7%	21.6%	1.0%	1088
Arauca	13.6%	42.3%	15.2%	28.3%	0.6%	1581
Armenia	13.6%	48.8%	14.7%	22.0%	0.9%	2587
Atlántico	17.8%	40.7%	17.6%	22.6%	1.3%	4931
Barrancabermeja	15.2%	46.2%	13.6%	23.7%	1.2%	1845
Barranquilla	13.8%	47.0%	13.7%	24.2%	1.2%	10592
Bello	14.0%	48.0%	13.1%	23.2%	1.7%	3031
Bogotá, D.C.	11.3%	51.8%	11.1%	24.8%	0.9%	62071
Bolívar	20.7%	33.3%	20.7%	23.5%	1.8%	7541
Boyacá	14.2%	45.3%	12.3%	27.6%	0.5%	7838
Bucaramanga	9.7%	57.0%	10.2%	22.0%	1.2%	4497
Buenaventura	18.3%	35.9%	18.2%	25.6%	2.1%	2787
Buga	12.9%	50.5%	12.8%	23.3%	0.5%	917
Caldas	16.6%	43.0%	15.5%	24.3%	0.7%	4429
Cali	15.0%	46.3%	13.6%	23.9%	1.2%	16580
Caquetá	17.5%	37.8%	17.6%	26.5%	0.7%	1657
Cartagena	17.8%	41.2%	16.6%	23.2%	1.2%	9659
Cartago	15.7%	45.8%	11.9%	25.4%	1.2%	1017
Casanare	14.3%	43.3%	14.8%	27.0%	0.6%	2177
Cauca	20.0%	35.9%	16.4%	26.2%	1.4%	8222
Cesar	19.4%	38.2%	17.2%	24.4%	0.7%	5409
Chocó	23.9%	37.3%	18.2%	19.0%	1.6%	2051
Chía	8.6%	59.0%	7.4%	24.0%	0.9%	1416
Ciénaga	21.2%	36.9%	19.5%	21.0%	1.3%	1060
Cundinamarca	13.6%	48.0%	11.7%	25.9%	0.7%	13372
Córdoba	20.1%	35.2%	19.4%	24.1%	1.3%	8943
Cúcuta	14.7%	47.5%	13.1%	23.8%	1.0%	5733
Dosquebradas	14.0%	49.1%	13.3%	23.2%	0.3%	1319
Duitama	8.1%	60.9%	9.5%	21.3%	0.2%	1251
Envigado	9.6%	58.4%	9.9%	21.9%	0.2%	1633
Facatativá	10.6%	51.4%	8.5%	29.1%	0.4%	1113
Florencia	14.2%	46.5%	15.0%	23.4%	0.9%	1383
Floridablanca	7.8%	55.4%	10.5%	25.2%	1.1%	1982
Fusagasugá	12.7%	52.8%	10.7%	23.1%	0.7%	1119
Girardot	19.2%	41.1%	13.9%	25.0%	0.8%	912

Continúa en la siguiente página



ETC/País	A	B	C	D	Omisión y multimarca	N° estudiantes
Girón	13.3%	46.9%	14.2%	24.9%	0.6%	1109
Guainía	19.7%	36.1%	17.5%	24.0%	2.7%	183
Guaviare	16.1%	45.6%	13.0%	24.6%	0.6%	621
Huila	16.6%	41.2%	14.4%	27.3%	0.5%	5192
Ibagué	13.1%	49.2%	12.2%	24.9%	0.6%	4714
Ipiales	12.3%	46.2%	11.4%	29.4%	0.7%	1066
Itagüí	14.6%	48.2%	13.8%	22.1%	1.4%	1746
Jamundí	15.1%	43.6%	13.8%	26.5%	1.0%	939
La Guajira	19.1%	36.3%	19.0%	24.3%	1.2%	2203
Lorica	21.9%	34.0%	20.5%	22.5%	1.1%	1329
Magangué	22.5%	33.8%	17.8%	24.2%	1.6%	1065
Magdalena	20.9%	34.6%	19.9%	22.8%	1.8%	5904
Maicao	19.7%	38.0%	19.1%	22.8%	0.4%	1178
Malambo	16.9%	42.7%	13.7%	25.5%	1.1%	787
Manizales	12.2%	47.3%	12.8%	27.0%	0.8%	2771
Medellín	14.1%	47.4%	14.5%	22.4%	1.6%	17124
Meta	14.7%	43.0%	14.7%	26.6%	0.9%	3790
Montería	16.5%	41.2%	16.1%	25.0%	1.1%	4178
Mosquera	10.4%	54.6%	9.2%	25.3%	0.5%	1158
Nariño	15.7%	41.1%	13.1%	29.0%	1.1%	6043
Neiva	13.7%	48.6%	10.9%	25.9%	0.8%	2950
Norte de Santander	15.1%	45.7%	13.0%	25.2%	1.0%	5090
Palmira	13.3%	49.0%	11.6%	25.0%	1.1%	2329
Pasto	11.5%	51.4%	10.6%	25.7%	0.8%	3212
Pereira	12.7%	49.2%	12.7%	24.8%	0.6%	3749
Piedecuesta	13.7%	53.5%	11.0%	20.9%	0.9%	1186
Pitalito	14.3%	48.8%	11.8%	24.2%	0.8%	1067
Popayán	12.9%	49.8%	11.5%	25.0%	0.9%	2459
Putumayo	15.6%	40.8%	13.8%	28.5%	1.3%	2701
Quibdó	19.2%	34.1%	19.7%	23.8%	3.3%	1086
Quindío	17.3%	41.2%	17.2%	23.6%	0.7%	2039
Riohacha	19.0%	37.0%	17.3%	25.1%	1.6%	1341
Rionegro	12.3%	53.0%	11.3%	22.3%	1.0%	1086
Risaralda	17.6%	43.7%	12.6%	25.6%	0.6%	1936
Sabaneta	10.3%	55.6%	12.7%	20.4%	1.0%	496
Sahagún	19.8%	39.7%	16.3%	23.7%	0.5%	1079
San Andrés	14.4%	39.3%	19.8%	25.7%	0.8%	529
Santa Marta	16.0%	42.3%	16.0%	24.0%	1.7%	4355
Santander	13.0%	48.7%	11.4%	26.5%	0.5%	6431

Continúa en la siguiente página

ETC/País	A	B	C	D	Omisión y multimarca	N° estudiantes
Sincelejo	17.0%	43.2%	16.4%	22.5%	0.8%	2696
Soacha	15.1%	44.5%	12.7%	26.7%	1.1%	4802
Sogamoso	10.4%	58.1%	7.3%	23.8%	0.4%	1267
Soledad	14.2%	44.2%	13.8%	26.3%	1.5%	4098
Sucre	20.5%	34.2%	19.4%	25.1%	0.9%	5462
Tolima	18.7%	39.8%	14.8%	25.9%	0.9%	6958
Tuluá	14.2%	49.2%	12.4%	23.1%	1.1%	1832
Tumaco	23.0%	31.6%	19.9%	23.5%	2.0%	1334
Tunja	9.5%	54.7%	10.3%	25.2%	0.2%	1740
Turbo	20.6%	33.9%	19.2%	24.6%	1.7%	1254
Uribe	27.8%	24.8%	19.0%	27.8%	0.7%	306
Valle del Cauca	17.7%	42.4%	14.7%	24.3%	0.9%	6252
Valledupar	17.4%	43.8%	15.3%	22.7%	0.9%	4092
Vichada	19.3%	36.1%	15.3%	27.2%	2.0%	404
Villavicencio	12.5%	49.3%	11.5%	25.9%	0.8%	4110
Yopal	12.5%	52.7%	11.5%	22.7%	0.5%	1395
Yumbo	17.9%	42.6%	15.4%	22.1%	1.9%	894
Zipaquirá	10.0%	54.4%	9.0%	26.1%	0.5%	1155
Colombia	15.1%	45.2%	14.0%	24.6%	1.1%	381884

*Es posible que los porcentajes mostrados no sumen exactamente 100 debido a aproximaciones decimales.

• **Pregunta 35.**

A continuación se presenta el desarrollo plano de un sólido.

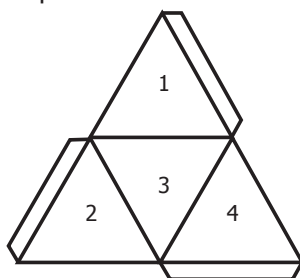

Del sólido que se puede construir con este desarrollo plano, es **correcto** afirmar que tiene en total

- A. 1 vértice.
- B. 2 bases.
- C. 3 aristas.
- D. 4 caras.

• **Estructura**

Competencia	Razonamiento
Componente	Espacial - métrico
Afirmación	Representar y describir propiedades de objetos tridimensionales desde diferentes posiciones y vistas.
Nivel de desempeño	Mínimo
Respuesta Correcta	D

• Resultados a nivel nacional y de Entidad Territorial Certificada (ETC)

ETC/País	A	B	C	D	Omisión y multimarca	N° estudiantes
Amazonas	7.3%	7.0%	20.6%	61.9%	3.2%	627
Antioquia	7.9%	9.4%	21.1%	59.8%	1.9%	19242
Apartadó	10.7%	13.1%	19.6%	55.2%	1.5%	1088
Arauca	7.3%	7.5%	21.3%	63.3%	0.6%	1581
Armenia	9.1%	9.1%	19.2%	61.3%	1.3%	2587
Atlántico	10.1%	11.2%	21.5%	55.5%	1.8%	4931
Barrancabermeja	9.0%	9.9%	22.8%	57.2%	1.0%	1845
Barranquilla	8.4%	10.1%	20.6%	59.6%	1.4%	10592
Bello	7.4%	8.3%	19.7%	63.2%	1.4%	3031
Bogotá, D.C.	5.7%	5.6%	18.1%	69.6%	0.9%	62071
Bolívar	10.3%	13.2%	21.6%	53.0%	2.0%	7541
Boyacá	5.1%	5.7%	20.3%	68.3%	0.7%	7838
Bucaramanga	6.2%	5.4%	17.1%	70.1%	1.1%	4497
Buenaventura	11.6%	12.3%	20.5%	53.4%	2.2%	2787
Buga	7.1%	9.3%	18.3%	64.4%	0.9%	917
Caldas	7.0%	8.3%	21.2%	62.9%	0.6%	4429
Cali	8.1%	9.0%	18.9%	62.7%	1.3%	16580
Caquetá	8.0%	9.3%	22.8%	58.3%	1.6%	1657
Cartagena	10.4%	12.7%	21.5%	54.2%	1.3%	9659
Cartago	6.4%	8.3%	21.7%	61.8%	1.8%	1017
Casanare	6.4%	8.1%	20.3%	64.5%	0.6%	2177
Cauca	7.4%	9.3%	18.7%	63.1%	1.4%	8222
Cesar	9.3%	12.2%	22.4%	55.2%	0.9%	5409
Chocó	10.5%	14.2%	21.0%	52.1%	2.1%	2051
Chía	3.7%	4.3%	17.7%	73.4%	0.8%	1416
Ciénaga	11.2%	13.7%	22.3%	50.9%	1.9%	1060
Cundinamarca	5.6%	6.0%	19.2%	68.4%	0.8%	13372
Córdoba	9.4%	11.7%	21.3%	56.3%	1.5%	8943
Cúcuta	6.9%	7.8%	20.8%	63.5%	1.0%	5733
Dosquebradas	6.7%	6.5%	18.1%	68.2%	0.5%	1319
Duitama	4.0%	4.8%	18.4%	72.5%	0.3%	1251
Envigado	5.5%	7.4%	15.4%	71.1%	0.6%	1633
Facatativá	4.9%	4.7%	19.8%	70.2%	0.4%	1113
Florencia	7.5%	8.0%	19.7%	63.3%	1.5%	1383
Floridablanca	5.5%	5.7%	18.6%	69.2%	1.0%	1982
Fusagasugá	5.6%	4.5%	20.5%	68.8%	0.6%	1119
Girardot	8.3%	8.4%	21.8%	60.9%	0.5%	912

Continúa en la siguiente página



ETC/País	A	B	C	D	Omisión y multimarca	N° estudiantes
Girón	6.4%	6.9%	20.1%	65.9%	0.6%	1109
Guainía	4.9%	7.1%	21.9%	64.5%	1.6%	183
Guaviare	7.2%	7.6%	20.1%	63.1%	1.9%	621
Huila	6.1%	6.9%	18.7%	67.5%	0.8%	5192
Ibagué	7.3%	7.7%	22.0%	62.2%	0.8%	4714
Ipiales	7.1%	7.0%	14.8%	70.4%	0.7%	1066
Itagüí	10.9%	10.8%	20.3%	56.5%	1.6%	1746
Jamundí	8.1%	8.6%	18.4%	64.0%	0.9%	939
La Guajira	10.8%	13.1%	21.3%	53.4%	1.4%	2203
Lorica	9.9%	13.5%	20.2%	54.9%	1.4%	1329
Magangué	9.3%	12.1%	18.0%	58.9%	1.7%	1065
Magdalena	9.9%	12.5%	21.8%	53.9%	1.9%	5904
Maicao	11.9%	10.4%	20.3%	56.0%	1.4%	1178
Malambo	9.5%	11.4%	16.5%	61.5%	1.0%	787
Manizales	6.5%	7.4%	19.5%	65.9%	0.8%	2771
Medellín	8.3%	9.3%	18.3%	62.4%	1.7%	17124
Meta	6.9%	8.0%	20.9%	62.9%	1.2%	3790
Montería	9.3%	10.8%	20.9%	57.8%	1.1%	4178
Mosquera	5.4%	4.1%	18.1%	71.8%	0.4%	1158
Nariño	6.8%	7.2%	19.4%	65.6%	1.0%	6043
Neiva	6.0%	6.7%	20.1%	66.4%	0.7%	2950
Norte de Santander	7.3%	7.8%	20.0%	64.1%	0.8%	5090
Palmira	5.2%	5.4%	17.0%	71.4%	1.2%	2329
Pasto	5.8%	5.2%	17.7%	70.4%	0.9%	3212
Pereira	6.7%	6.8%	18.3%	67.6%	0.6%	3749
Piedecuesta	7.5%	7.0%	17.5%	66.7%	1.3%	1186
Pitalito	5.6%	6.8%	19.2%	67.2%	1.1%	1067
Popayán	6.1%	5.8%	17.8%	69.4%	0.9%	2459
Putumayo	6.1%	7.7%	19.2%	65.8%	1.2%	2701
Quibdó	9.7%	16.2%	20.3%	50.3%	3.5%	1086
Quindío	7.7%	11.2%	19.8%	60.3%	1.0%	2039
Riohacha	8.4%	11.5%	19.4%	59.2%	1.6%	1341
Rionegro	6.2%	4.8%	17.3%	71.0%	0.7%	1086
Risaralda	7.1%	7.5%	20.4%	64.3%	0.7%	1936
Sabaneta	6.7%	8.3%	12.7%	71.4%	1.0%	496
Sahagún	8.1%	10.9%	24.0%	55.8%	1.2%	1079
San Andrés	11.9%	12.9%	21.7%	52.9%	0.6%	529
Santa Marta	9.9%	11.8%	22.4%	54.1%	1.8%	4355
Santander	5.9%	6.5%	19.0%	67.9%	0.7%	6431

Continúa en la siguiente página

ETC/País	A	B	C	D	Omisión y multimarca	N° estudiantes
Sincelejo	9.4%	10.8%	22.1%	57.0%	0.7%	2696
Soacha	6.8%	7.2%	18.5%	66.4%	1.1%	4802
Sogamoso	5.1%	3.0%	21.8%	69.9%	0.2%	1267
Soledad	9.1%	9.8%	20.1%	59.4%	1.6%	4098
Sucre	8.3%	10.9%	22.6%	57.0%	1.2%	5462
Tolima	7.3%	8.3%	20.9%	62.4%	1.0%	6958
Tuluá	6.9%	6.7%	19.6%	65.7%	1.1%	1832
Tumaco	11.7%	13.6%	20.8%	51.3%	2.5%	1334
Tunja	4.3%	4.9%	19.5%	70.9%	0.5%	1740
Turbo	10.8%	13.5%	19.5%	54.7%	1.5%	1254
Uribe	8.5%	12.4%	19.0%	59.8%	0.3%	306
Valle del Cauca	8.1%	8.5%	19.4%	62.9%	1.1%	6252
Valledupar	9.2%	10.4%	22.2%	57.3%	0.9%	4092
Vichada	5.4%	7.2%	21.5%	62.6%	3.2%	404
Villavicencio	7.6%	6.9%	20.5%	64.2%	0.9%	4110
Yopal	6.2%	6.6%	19.9%	66.4%	0.9%	1395
Yumbo	7.7%	8.2%	19.1%	62.3%	2.7%	894
Zipaquirá	4.2%	4.8%	18.9%	71.2%	0.9%	1155
Colombia	7.5%	8.4%	19.7%	63.2%	1.2%	381884

*Es posible que los porcentajes mostrados no sumen exactamente 100 debido a aproximaciones decimales.

• **Pregunta 36.**

La gráfica muestra el número de estudiantes que asistió a una biblioteca escolar durante una semana.

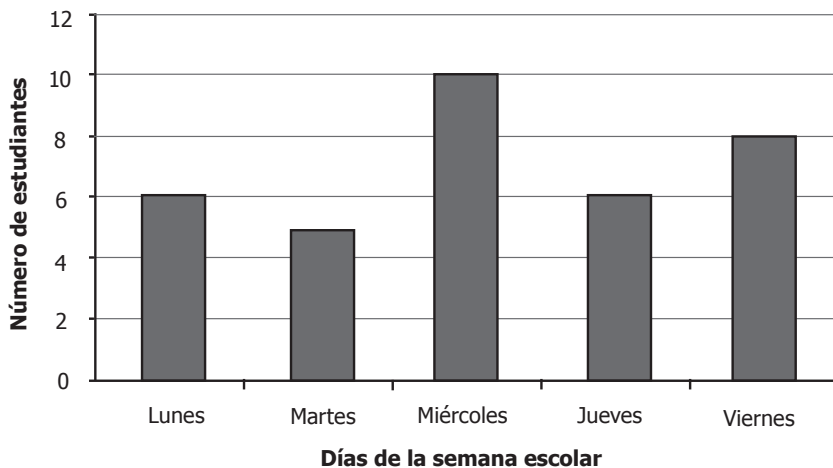

Gráfica

¿Cuál es el promedio diario de asistencia a la biblioteca durante esta semana?

- A. 6
- B. 7
- C. 8
- D. 10

• **Estructura**

Competencia	Comunicación
Componente	Aleatorio
Afirmación	Reconocer la media, mediana y moda con base en la representación de un conjunto de datos y explicar sus diferencias en distribuciones diferentes.
Nivel de desempeño	Avanzado
Respuesta Correcta	B

• Resultados a nivel nacional y de Entidad Territorial Certificada (ETC)

ETC/País	A	B	C	D	Omisión y multimarca	N° estudiantes
Amazonas	23.4%	13.9%	12.4%	47.0%	3.2%	627
Antioquia	30.8%	19.5%	11.8%	35.9%	1.8%	19242
Apartadó	28.8%	18.8%	14.0%	37.1%	1.4%	1088
Arauca	31.9%	19.8%	12.8%	35.0%	0.5%	1581
Armenia	34.0%	21.9%	11.6%	31.3%	1.1%	2587
Atlántico	23.9%	18.1%	13.2%	43.2%	1.6%	4931
Barrancabermeja	29.4%	22.4%	11.7%	35.4%	1.2%	1845
Barranquilla	31.5%	23.1%	11.6%	32.3%	1.4%	10592
Bello	35.5%	21.3%	9.9%	31.7%	1.6%	3031
Bogotá, D.C.	37.4%	26.5%	9.4%	25.8%	0.9%	62071
Bolívar	20.9%	17.0%	14.4%	45.8%	1.9%	7541
Boyacá	31.5%	26.1%	10.2%	31.5%	0.7%	7838
Bucaramanga	35.3%	31.3%	9.6%	22.9%	0.9%	4497
Buenaventura	22.7%	17.5%	13.6%	43.8%	2.4%	2787
Buga	35.8%	20.8%	11.9%	30.9%	0.7%	917
Caldas	30.7%	18.6%	12.3%	37.7%	0.8%	4429
Cali	33.2%	23.0%	11.1%	31.5%	1.2%	16580
Caquetá	30.1%	20.8%	13.6%	34.5%	1.0%	1657
Cartagena	27.4%	21.4%	13.2%	36.6%	1.4%	9659
Cartago	33.0%	22.9%	9.7%	33.1%	1.2%	1017
Casanare	31.3%	21.5%	11.8%	34.7%	0.6%	2177
Cauca	25.1%	17.3%	11.5%	44.7%	1.4%	8222
Cesar	25.3%	19.1%	13.0%	41.7%	1.0%	5409
Chocó	21.4%	19.4%	12.4%	44.5%	2.3%	2051
Chía	40.2%	30.6%	7.6%	20.9%	0.7%	1416
Ciénaga	22.5%	16.0%	13.2%	45.6%	2.6%	1060
Cundinamarca	33.0%	25.3%	9.6%	31.4%	0.8%	13372
Córdoba	25.1%	16.5%	13.6%	43.5%	1.4%	8943
Cúcuta	30.3%	25.2%	10.1%	33.4%	1.0%	5733
Dosquebradas	37.8%	23.5%	10.0%	28.1%	0.6%	1319
Duitama	36.1%	35.4%	8.3%	20.0%	0.2%	1251
Envigado	37.3%	35.1%	9.3%	17.7%	0.6%	1633
Facatativá	37.6%	23.1%	7.9%	30.5%	0.9%	1113
Florencia	29.6%	24.9%	10.3%	33.7%	1.4%	1383
Floridablanca	35.8%	31.9%	8.3%	23.2%	0.8%	1982
Fusagasugá	40.8%	20.7%	9.8%	27.8%	0.9%	1119
Girardot	29.4%	19.2%	10.6%	39.9%	0.9%	912

Continúa en la siguiente página



ETC/País	A	B	C	D	Omisión y multimarca	N° estudiantes
Girón	38.6%	21.2%	10.3%	29.5%	0.5%	1109
Guainía	28.4%	14.8%	10.4%	44.3%	2.2%	183
Guaviare	33.7%	19.8%	10.0%	35.4%	1.1%	621
Huila	29.4%	20.1%	11.2%	38.6%	0.7%	5192
Ibagué	35.2%	24.4%	10.5%	29.2%	0.7%	4714
Ipiales	30.2%	25.7%	12.5%	31.1%	0.5%	1066
Itagüí	31.1%	23.3%	12.5%	31.7%	1.5%	1746
Jamundí	30.9%	21.5%	12.8%	33.9%	1.0%	939
La Guajira	23.2%	19.6%	14.3%	41.4%	1.5%	2203
Lorica	20.7%	15.7%	15.1%	47.2%	1.4%	1329
Magangué	23.3%	16.2%	13.3%	45.4%	1.8%	1065
Magdalena	21.3%	16.3%	14.1%	46.3%	2.0%	5904
Maicao	24.0%	18.3%	12.2%	44.7%	0.8%	1178
Malambo	22.0%	26.8%	10.5%	39.3%	1.4%	787
Manizales	36.0%	23.1%	11.3%	28.8%	0.8%	2771
Medellín	34.7%	22.8%	11.8%	29.0%	1.7%	17124
Meta	33.9%	20.8%	10.8%	33.4%	1.1%	3790
Montería	27.6%	21.3%	12.1%	38.2%	0.9%	4178
Mosquera	39.6%	22.6%	9.9%	26.8%	1.0%	1158
Nariño	26.4%	23.2%	11.2%	38.0%	1.3%	6043
Neiva	32.3%	24.4%	9.5%	33.1%	0.7%	2950
Norte de Santander	32.0%	22.0%	10.6%	34.6%	0.8%	5090
Palmira	33.2%	27.6%	10.3%	27.9%	1.0%	2329
Pasto	30.0%	28.1%	8.6%	32.4%	0.9%	3212
Pereira	38.2%	23.3%	11.0%	26.8%	0.7%	3749
Piedecuesta	38.4%	25.5%	9.8%	24.8%	1.5%	1186
Pitalito	34.4%	26.7%	11.2%	27.1%	0.6%	1067
Popayán	33.2%	26.1%	9.0%	30.5%	1.1%	2459
Putumayo	30.0%	20.7%	11.3%	36.4%	1.7%	2701
Quibdó	23.1%	17.5%	12.5%	43.2%	3.7%	1086
Quindío	30.0%	21.0%	12.6%	35.4%	1.0%	2039
Riohacha	27.3%	19.2%	12.5%	39.5%	1.5%	1341
Rionegro	36.6%	24.8%	10.3%	27.4%	0.8%	1086
Risaralda	32.3%	19.9%	10.8%	35.8%	1.1%	1936
Sabaneta	36.3%	32.9%	8.1%	21.8%	1.0%	496
Sahagún	31.0%	17.1%	11.6%	39.4%	0.9%	1079
San Andrés	31.6%	18.1%	13.6%	35.7%	0.9%	529
Santa Marta	30.5%	19.3%	13.2%	35.1%	1.8%	4355
Santander	32.4%	27.0%	9.7%	30.2%	0.7%	6431

Continúa en la siguiente página

ETC/País	A	B	C	D	Omisión y multimarca	N° estudiantes
Sincelejo	29.3%	19.3%	13.0%	37.6%	0.8%	2696
Soacha	34.6%	19.8%	10.5%	33.8%	1.3%	4802
Sogamoso	35.2%	33.5%	8.4%	22.7%	0.3%	1267
Soledad	29.6%	20.2%	12.4%	36.3%	1.5%	4098
Sucre	23.9%	16.3%	13.2%	45.6%	1.0%	5462
Tolima	27.8%	18.2%	12.0%	40.8%	1.2%	6958
Tuluá	33.4%	23.4%	11.1%	31.2%	0.9%	1832
Tumaco	19.2%	15.8%	15.1%	47.0%	2.9%	1334
Tunja	37.8%	30.7%	9.4%	21.7%	0.3%	1740
Turbo	25.8%	13.8%	13.7%	44.6%	2.1%	1254
Uribe	20.6%	14.1%	12.4%	52.3%	0.7%	306
Valle del Cauca	30.3%	20.2%	11.5%	36.9%	1.0%	6252
Valledupar	29.6%	20.5%	12.0%	36.9%	1.1%	4092
Vichada	25.0%	20.8%	11.4%	40.6%	2.2%	404
Villavicencio	34.7%	25.7%	10.9%	27.8%	0.9%	4110
Yopal	33.5%	28.0%	9.2%	28.4%	0.9%	1395
Yumbo	28.3%	20.0%	13.4%	36.2%	2.0%	894
Zipaquirá	35.2%	30.2%	8.8%	25.0%	0.8%	1155
Colombia	31.5%	22.6%	11.2%	33.5%	1.2%	381884

*Es posible que los porcentajes mostrados no sumen exactamente 100 debido a aproximaciones decimales.

• **Pregunta 37.**

Para seleccionar los géneros musicales con los cuales se va a animar una fiesta de 15 años, se realizó una encuesta sobre preferencias, a un grupo de jóvenes.

La gráfica muestra información obtenida en la encuesta.

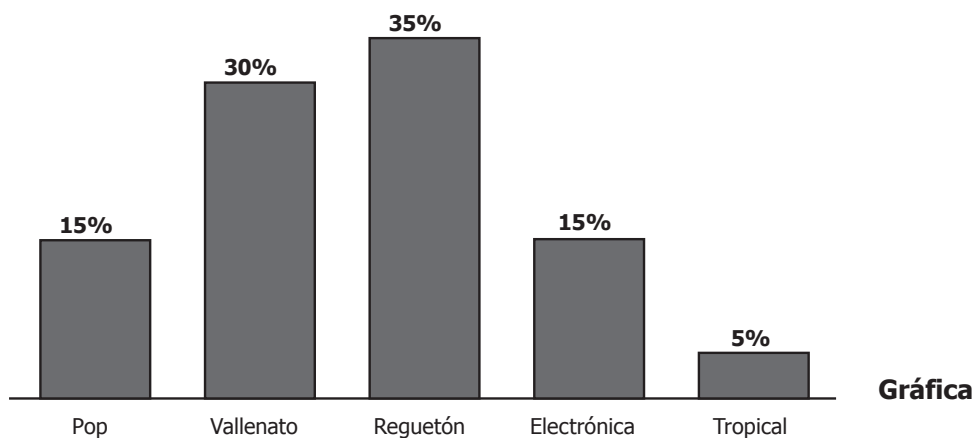

De la información anterior se puede concluir que en la fiesta debería predominar

- A. la música tropical.
- B. el reguetón.
- C. el vallenato.
- D. la música electrónica.

• **Estructura**

Competencia	Comunicación
Componente	Aleatorio
Afirmación	Reconocer la media, mediana y moda con base en la representación de un conjunto de datos y explicar sus diferencias en distribuciones diferentes.
Nivel de desempeño	Mínimo
Respuesta Correcta	B

• Resultados a nivel nacional y de Entidad Territorial Certificada (ETC)

ETC/País	A	B	C	D	Omisión y multimarca	N° estudiantes
Amazonas	9.1%	74.2%	8.5%	4.6%	3.7%	627
Antioquia	6.9%	78.7%	7.6%	5.1%	1.7%	19242
Apartadó	7.5%	73.3%	9.9%	8.4%	0.9%	1088
Arauca	6.2%	82.4%	8.0%	3.1%	0.4%	1581
Armenia	6.6%	77.7%	8.7%	5.8%	1.2%	2587
Atlántico	8.1%	75.5%	8.6%	6.4%	1.4%	4931
Barrancabermeja	7.4%	76.7%	9.7%	5.3%	0.9%	1845
Barranquilla	6.5%	79.3%	7.8%	5.2%	1.2%	10592
Bello	6.5%	79.1%	7.9%	5.0%	1.6%	3031
Bogotá, D.C.	4.7%	83.8%	7.3%	3.2%	0.9%	62071
Bolívar	9.3%	71.6%	10.3%	7.3%	1.5%	7541
Boyacá	6.1%	83.6%	6.6%	3.1%	0.6%	7838
Bucaramanga	4.6%	84.0%	6.8%	3.6%	1.0%	4497
Buenaventura	10.3%	72.2%	8.4%	7.2%	1.8%	2787
Buga	4.4%	84.6%	6.0%	4.5%	0.5%	917
Caldas	6.6%	81.4%	7.2%	4.1%	0.6%	4429
Cali	6.3%	79.7%	8.1%	4.9%	1.0%	16580
Caquetá	8.3%	77.2%	8.9%	4.6%	0.9%	1657
Cartagena	8.0%	74.3%	9.6%	6.9%	1.1%	9659
Cartago	6.4%	81.7%	7.6%	2.9%	1.5%	1017
Casanare	5.9%	82.1%	7.2%	3.9%	0.9%	2177
Cauca	7.8%	78.9%	7.0%	4.8%	1.5%	8222
Cesar	7.8%	76.2%	9.6%	5.7%	0.7%	5409
Chocó	8.7%	72.8%	9.5%	6.9%	2.0%	2051
Chía	3.7%	87.4%	5.9%	2.4%	0.6%	1416
Ciénaga	9.2%	70.8%	11.3%	7.1%	1.5%	1060
Cundinamarca	5.0%	84.8%	6.5%	3.0%	0.7%	13372
Córdoba	7.4%	76.7%	8.8%	5.8%	1.3%	8943
Cúcuta	5.8%	81.7%	7.3%	4.3%	0.9%	5733
Dosquebradas	3.3%	84.2%	7.6%	4.3%	0.6%	1319
Duitama	4.6%	86.3%	7.1%	1.8%	0.2%	1251
Envigado	4.8%	83.0%	6.7%	4.8%	0.7%	1633
Facatativá	4.4%	87.2%	5.7%	1.7%	1.0%	1113
Florencia	6.7%	79.8%	8.0%	4.6%	1.0%	1383
Floridablanca	3.8%	85.2%	7.2%	3.0%	0.9%	1982
Fusagasugá	4.5%	84.6%	6.2%	3.7%	1.1%	1119
Girardot	5.6%	80.6%	8.6%	4.6%	0.7%	912

Continúa en la siguiente página



ETC/País	A	B	C	D	Omisión y multimarca	N° estudiantes
Girón	6.1%	81.2%	8.4%	3.5%	0.8%	1109
Guainía	5.5%	86.3%	3.3%	2.7%	2.2%	183
Guaviare	6.6%	80.5%	8.2%	2.9%	1.8%	621
Huila	6.2%	83.5%	6.3%	3.4%	0.6%	5192
Ibagué	4.8%	82.3%	8.1%	4.1%	0.7%	4714
Ipiales	4.9%	84.9%	6.5%	3.2%	0.6%	1066
Itagüí	9.5%	72.5%	10.0%	6.8%	1.3%	1746
Jamundí	6.0%	80.2%	8.4%	4.7%	0.7%	939
La Guajira	9.0%	71.9%	10.4%	7.4%	1.1%	2203
Lorica	6.5%	75.8%	9.6%	7.2%	1.0%	1329
Magangué	6.4%	78.3%	8.0%	5.4%	1.9%	1065
Magdalena	7.8%	73.9%	10.3%	6.3%	1.7%	5904
Maicao	7.2%	75.8%	10.4%	5.9%	0.7%	1178
Malambo	6.5%	76.9%	8.1%	7.6%	0.9%	787
Manizales	4.7%	84.2%	6.7%	3.6%	0.8%	2771
Medellín	6.7%	77.0%	8.9%	5.8%	1.6%	17124
Meta	6.4%	80.2%	7.5%	4.9%	1.0%	3790
Montería	7.8%	78.1%	7.7%	5.4%	1.1%	4178
Mosquera	4.2%	86.4%	6.5%	2.3%	0.6%	1158
Nariño	6.6%	83.2%	5.6%	3.6%	1.0%	6043
Neiva	4.6%	84.7%	6.9%	3.0%	0.8%	2950
Norte de Santander	6.4%	81.9%	7.4%	3.5%	0.8%	5090
Palmira	4.6%	84.5%	6.9%	3.0%	0.9%	2329
Pasto	5.2%	85.3%	5.9%	2.7%	0.8%	3212
Pereira	4.9%	84.1%	6.6%	3.8%	0.6%	3749
Piedecuesta	7.2%	80.6%	7.3%	3.6%	1.3%	1186
Pitalito	6.3%	84.2%	6.3%	2.7%	0.6%	1067
Popayán	5.2%	84.0%	6.6%	3.1%	1.0%	2459
Putumayo	7.3%	81.3%	6.7%	3.3%	1.5%	2701
Quibdó	7.8%	69.4%	10.7%	8.5%	3.6%	1086
Quindío	8.1%	77.3%	8.4%	5.4%	0.7%	2039
Riohacha	6.1%	78.4%	8.8%	5.4%	1.3%	1341
Rionegro	6.0%	82.7%	7.2%	3.5%	0.6%	1086
Risaralda	4.9%	82.6%	6.6%	5.1%	0.9%	1936
Sabaneta	4.4%	84.1%	7.3%	3.4%	0.8%	496
Sahagún	7.4%	80.1%	7.6%	4.3%	0.6%	1079
San Andrés	8.5%	73.0%	8.5%	8.7%	1.3%	529
Santa Marta	7.9%	75.1%	9.4%	6.1%	1.5%	4355
Santander	5.6%	84.7%	5.9%	3.0%	0.8%	6431

Continúa en la siguiente página

ETC/País	A	B	C	D	Omisión y multimarca	Nº estudiantes
Sincelejo	7.0%	77.5%	8.8%	5.9%	0.8%	2696
Soacha	6.1%	81.0%	7.8%	4.0%	1.2%	4802
Sogamoso	5.3%	86.5%	5.8%	2.0%	0.5%	1267
Soledad	7.4%	77.1%	8.3%	5.7%	1.5%	4098
Sucre	7.2%	78.3%	8.0%	5.7%	0.9%	5462
Tolima	7.2%	80.2%	7.3%	4.2%	1.1%	6958
Tuluá	4.7%	83.4%	6.8%	4.3%	0.8%	1832
Tumaco	10.0%	72.9%	7.4%	7.8%	1.9%	1334
Tunja	4.0%	84.7%	7.9%	2.9%	0.5%	1740
Turbo	9.3%	74.0%	8.4%	7.1%	1.2%	1254
Uribe	9.8%	71.6%	10.1%	7.8%	0.7%	306
Valle del Cauca	6.6%	80.5%	7.5%	4.5%	0.9%	6252
Valledupar	7.0%	78.2%	8.7%	5.1%	1.0%	4092
Vichada	9.2%	74.5%	7.2%	6.9%	2.2%	404
Villavicencio	4.7%	81.3%	8.5%	4.7%	0.8%	4110
Yopal	5.2%	83.8%	7.7%	2.8%	0.6%	1395
Yumbo	7.3%	80.8%	6.8%	3.8%	1.3%	894
Zipaquirá	4.9%	86.4%	5.5%	2.3%	0.9%	1155
Colombia	6.3%	80.3%	7.8%	4.5%	1.1%	381884

*Es posible que los porcentajes mostrados no sumen exactamente 100 debido a aproximaciones decimales.

• Pregunta 38.

Una persona está organizando una fiesta de cumpleaños y para esto cotizó en 4 empresas especializadas en realizar este tipo de eventos.

La tabla muestra las cotizaciones de estas empresas.

Artículo	Empresa 1	Empresa 2	Empresa 3	Empresa 4
Sombrero (unidad)	4.400	4.600	4.300	4.000
Comida (1 plato)	6.500	7.500	8.000	10.000
Recordatorios (unidad)	3.000	2.800	2.900	3.500
Decoración	45.000	65.000	60.000	50.000
Animación	200.000	140.000	150.000	100.000

Tabla

¿En cuál de las empresas resulta más económico comprar los recordatorios y los sombreros?

- A. En la empresa 1.
- B. En la empresa 2.
- C. En la empresa 3.
- D. En la empresa 4.

• Estructura

Competencia	Resolución
Componente	Aleatorio
Afirmación	Resolver y formular problemas a partir de un conjunto de datos presentado en tablas, diagramas de barras y diagrama circular.
Nivel de desempeño	Satisfactorio
Respuesta Correcta	C

• Resultados a nivel nacional y de Entidad Territorial Certificada (ETC)

ETC/País	A	B	C	D	Omisión y multimarca	N° estudiantes
Amazonas	20.1%	20.7%	25.8%	30.0%	3.3%	627
Antioquia	17.9%	18.4%	38.3%	23.8%	1.6%	19242
Apartadó	19.9%	20.0%	38.1%	20.8%	1.2%	1088
Arauca	15.4%	19.0%	40.5%	24.5%	0.6%	1581
Armenia	17.2%	18.6%	39.5%	23.6%	1.1%	2587
Atlántico	19.7%	20.4%	33.1%	25.5%	1.3%	4931
Barrancabermeja	18.0%	18.0%	40.9%	22.2%	0.9%	1845
Barranquilla	17.6%	19.4%	39.7%	22.2%	1.0%	10592
Bello	17.6%	17.1%	42.5%	21.6%	1.2%	3031
Bogotá, D.C.	13.4%	16.1%	47.0%	22.7%	0.9%	62071
Bolívar	23.1%	22.3%	27.7%	25.4%	1.4%	7541
Boyacá	14.0%	16.4%	46.7%	22.5%	0.4%	7838
Bucaramanga	12.2%	15.5%	52.2%	19.3%	0.9%	4497
Buenaventura	21.3%	18.8%	31.5%	26.5%	1.9%	2787
Buga	16.4%	18.9%	42.0%	22.1%	0.7%	917
Caldas	17.7%	19.0%	37.3%	25.4%	0.6%	4429
Cali	16.0%	17.8%	42.8%	22.3%	1.1%	16580
Caquetá	17.3%	20.9%	35.1%	26.1%	0.7%	1657
Cartagena	21.1%	20.1%	35.3%	22.5%	1.0%	9659
Cartago	16.7%	17.5%	38.5%	25.9%	1.4%	1017
Casanare	15.0%	18.7%	41.8%	24.0%	0.4%	2177
Cauca	18.3%	18.9%	33.1%	28.5%	1.3%	8222
Cesar	19.8%	19.9%	34.0%	25.9%	0.5%	5409
Chocó	21.7%	19.6%	31.3%	26.1%	1.3%	2051
Chía	10.7%	14.3%	53.1%	21.2%	0.7%	1416
Ciénaga	23.3%	22.4%	27.9%	25.0%	1.4%	1060
Cundinamarca	13.7%	17.3%	45.2%	23.2%	0.7%	13372
Córdoba	20.6%	21.1%	30.5%	26.7%	1.1%	8943
Cúcuta	14.3%	17.8%	45.4%	21.5%	0.9%	5733
Dosquebradas	13.9%	16.9%	45.3%	23.4%	0.5%	1319
Duitama	11.3%	12.6%	57.5%	18.5%	0.2%	1251
Envigado	14.8%	15.2%	52.5%	17.1%	0.4%	1633
Facatativá	11.9%	14.6%	51.2%	21.9%	0.4%	1113
Florencia	14.7%	18.1%	44.3%	21.8%	1.1%	1383
Floridablanca	11.2%	15.4%	52.5%	20.2%	0.7%	1982
Fusagasugá	15.6%	17.1%	44.1%	22.2%	1.0%	1119
Girardot	20.2%	18.8%	35.3%	25.2%	0.5%	912

Continúa en la siguiente página



ETC/País	A	B	C	D	Omisión y multimarca	N° estudiantes
Girón	14.4%	17.5%	46.7%	21.0%	0.4%	1109
Guainía	17.5%	18.0%	30.6%	32.2%	1.6%	183
Guaviare	17.2%	21.3%	34.8%	26.1%	0.6%	621
Huila	15.0%	19.0%	41.5%	24.0%	0.5%	5192
Ibagué	14.1%	16.6%	45.4%	23.3%	0.6%	4714
Ipiales	11.1%	17.5%	47.7%	23.5%	0.3%	1066
Itagüí	19.8%	18.2%	39.3%	21.2%	1.4%	1746
Jamundí	17.9%	19.6%	38.3%	23.3%	0.9%	939
La Guajira	23.0%	19.4%	29.9%	27.1%	0.7%	2203
Lorica	23.2%	24.2%	24.9%	26.9%	0.9%	1329
Magangué	18.3%	23.4%	30.2%	26.3%	1.8%	1065
Magdalena	22.8%	20.8%	28.8%	25.9%	1.6%	5904
Maicao	20.0%	19.4%	33.7%	26.2%	0.6%	1178
Malambo	16.5%	20.3%	39.5%	23.1%	0.5%	787
Manizales	15.7%	18.0%	42.0%	23.4%	0.9%	2771
Medellín	17.2%	18.1%	41.9%	21.3%	1.6%	17124
Meta	16.8%	18.6%	38.8%	25.0%	0.8%	3790
Montería	20.0%	19.6%	37.4%	22.1%	0.8%	4178
Mosquera	14.5%	13.4%	49.9%	21.4%	0.8%	1158
Nariño	15.1%	17.6%	43.0%	23.6%	0.8%	6043
Neiva	14.8%	16.1%	45.7%	22.6%	0.8%	2950
Norte de Santander	15.3%	17.9%	42.1%	23.9%	0.8%	5090
Palmira	14.5%	16.0%	47.4%	20.9%	1.2%	2329
Pasto	13.3%	15.8%	48.3%	21.7%	0.8%	3212
Pereira	14.9%	16.2%	45.2%	23.0%	0.7%	3749
Piedecuesta	13.2%	16.4%	49.1%	20.6%	0.8%	1186
Pitalito	11.7%	17.4%	44.0%	26.1%	0.7%	1067
Popayán	13.0%	16.6%	45.8%	23.6%	1.0%	2459
Putumayo	14.0%	18.6%	42.3%	24.0%	1.1%	2701
Quibdó	18.9%	20.2%	28.6%	28.8%	3.5%	1086
Quindío	16.9%	18.5%	37.2%	26.6%	0.8%	2039
Riohacha	16.6%	19.2%	37.8%	25.1%	1.3%	1341
Rionegro	15.7%	15.0%	49.5%	19.2%	0.6%	1086
Risaralda	17.9%	16.8%	37.9%	26.7%	0.7%	1936
Sabaneta	12.7%	15.5%	49.8%	21.2%	0.8%	496
Sahagún	20.6%	19.4%	35.0%	24.4%	0.6%	1079
San Andrés	21.2%	23.3%	33.6%	21.4%	0.6%	529
Santa Marta	19.6%	20.2%	34.4%	24.1%	1.6%	4355
Santander	14.6%	16.5%	46.3%	21.9%	0.7%	6431

Continúa en la siguiente página

ETC/País	A	B	C	D	Omisión y multimarca	Nº estudiantes
Sincelejo	19.8%	21.1%	34.8%	23.6%	0.7%	2696
Soacha	15.6%	17.7%	40.8%	24.9%	1.0%	4802
Sogamoso	10.5%	15.9%	52.2%	21.2%	0.3%	1267
Soledad	18.4%	19.7%	38.8%	21.9%	1.1%	4098
Sucre	20.0%	20.8%	31.3%	27.1%	0.8%	5462
Tolima	17.3%	18.5%	36.6%	26.7%	0.8%	6958
Tuluá	15.4%	17.5%	41.8%	24.3%	0.9%	1832
Tumaco	22.0%	18.5%	26.9%	30.4%	2.1%	1334
Tunja	12.9%	14.7%	50.9%	21.1%	0.3%	1740
Turbo	21.9%	19.1%	29.6%	28.5%	0.9%	1254
Uribe	24.2%	24.2%	22.2%	29.1%	0.3%	306
Valle del Cauca	17.3%	18.8%	37.0%	26.0%	0.9%	6252
Valledupar	18.1%	19.6%	35.9%	25.6%	0.7%	4092
Vichada	16.1%	18.6%	37.9%	25.2%	2.2%	404
Villavicencio	13.9%	17.6%	43.8%	24.0%	0.7%	4110
Yopal	13.8%	14.9%	47.3%	23.4%	0.5%	1395
Yumbo	16.1%	19.5%	38.6%	24.6%	1.2%	894
Zipaquirá	11.8%	15.3%	50.6%	21.7%	0.5%	1155
Colombia	16.5%	18.0%	40.9%	23.6%	1.0%	381884

*Es posible que los porcentajes mostrados no sumen exactamente 100 debido a aproximaciones decimales.

• **Pregunta 39.**

En la figura se presentan los tres primeros pasos de una secuencia de construcción con la cual se puede obtener un diseño similar a una de las obras del maestro colombiano Omar Rayo.

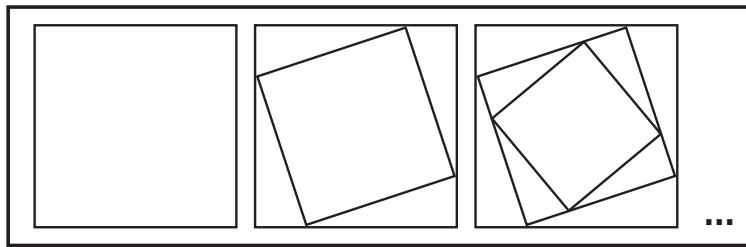

Figura

¿Cuál de las siguientes fotografías corresponde a la obra relacionada con la secuencia anterior?

A.



B.



C.

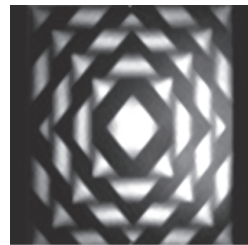

D.

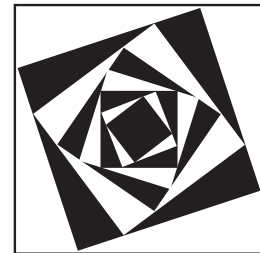

• **Estructura**

Competencia	Resolución
Componente	Espacial - métrico
Afirmación	Resolver y formular problemas usando modelos geométricos.
Nivel de desempeño	Mínimo
Respuesta Correcta	D

• Resultados a nivel nacional y de Entidad Territorial Certificada (ETC)

ETC/País	A	B	C	D	Omisión y multimarca	N° estudiantes
Amazonas	4.1%	5.4%	10.0%	76.1%	4.3%	627
Antioquia	5.2%	7.0%	7.8%	78.4%	1.7%	19242
Apartadó	5.9%	10.2%	11.2%	71.5%	1.2%	1088
Arauca	4.0%	5.2%	7.9%	82.2%	0.6%	1581
Armenia	5.3%	6.6%	7.5%	79.4%	1.2%	2587
Atlántico	6.0%	8.9%	11.1%	72.5%	1.5%	4931
Barrancabermeja	4.8%	8.0%	8.0%	78.1%	1.2%	1845
Barranquilla	5.3%	7.6%	7.2%	78.7%	1.2%	10592
Bello	4.7%	6.3%	7.0%	80.7%	1.4%	3031
Bogotá, D.C.	3.2%	4.3%	4.6%	87.0%	0.9%	62071
Bolívar	7.1%	9.9%	13.1%	68.0%	1.9%	7541
Boyacá	3.6%	4.6%	6.0%	85.0%	0.8%	7838
Bucaramanga	3.4%	4.1%	4.6%	87.2%	0.8%	4497
Buenaventura	6.7%	10.2%	9.9%	71.1%	2.0%	2787
Buga	3.6%	5.0%	6.1%	84.2%	1.1%	917
Caldas	4.8%	6.2%	7.2%	81.3%	0.6%	4429
Cali	4.5%	6.6%	6.6%	81.1%	1.1%	16580
Caquetá	6.6%	7.4%	9.7%	75.3%	1.0%	1657
Cartagena	6.5%	9.3%	10.0%	73.0%	1.2%	9659
Cartago	4.0%	6.3%	5.7%	82.8%	1.2%	1017
Casanare	3.8%	5.2%	6.5%	83.5%	1.0%	2177
Cauca	4.9%	7.0%	10.0%	76.8%	1.3%	8222
Cesar	6.2%	8.4%	10.8%	74.0%	0.7%	5409
Chocó	6.8%	9.8%	15.8%	65.7%	2.0%	2051
Chía	3.4%	2.6%	3.2%	90.2%	0.6%	1416
Ciénaga	7.8%	9.1%	11.7%	69.7%	1.7%	1060
Cundinamarca	3.2%	4.2%	5.6%	86.3%	0.7%	13372
Córdoba	6.3%	8.5%	11.7%	72.1%	1.3%	8943
Cúcuta	3.9%	5.3%	5.5%	84.3%	1.0%	5733
Dosquebradas	3.4%	3.6%	4.6%	87.6%	0.7%	1319
Duitama	3.1%	3.4%	2.6%	90.6%	0.3%	1251
Envigado	4.6%	5.7%	6.2%	83.0%	0.5%	1633
Facatativá	3.4%	2.8%	3.1%	90.4%	0.4%	1113
Florencia	5.0%	4.9%	7.2%	82.0%	0.9%	1383
Floridablanca	3.2%	4.3%	4.1%	87.2%	1.1%	1982
Fusagasugá	2.9%	4.7%	3.7%	87.6%	1.2%	1119
Girardot	3.8%	5.6%	7.6%	81.9%	1.1%	912

Continúa en la siguiente página



ETC/País	A	B	C	D	Omisión y multimarca	N° estudiantes
Girón	3.4%	2.9%	6.7%	86.7%	0.3%	1109
Guainía	4.9%	4.4%	8.2%	79.2%	3.3%	183
Guaviare	5.5%	4.2%	6.6%	82.0%	1.8%	621
Huila	4.2%	4.4%	6.4%	84.2%	0.8%	5192
Ibagué	4.0%	5.6%	5.9%	83.8%	0.6%	4714
Ipiales	3.8%	4.6%	5.0%	86.4%	0.3%	1066
Itagüí	6.1%	10.4%	8.1%	73.7%	1.7%	1746
Jamundí	3.8%	5.5%	7.5%	82.3%	0.9%	939
La Guajira	8.4%	9.4%	12.0%	69.4%	0.8%	2203
Lorica	7.1%	10.2%	14.8%	66.7%	1.1%	1329
Magangué	6.8%	7.8%	9.2%	74.6%	1.7%	1065
Magdalena	6.5%	9.7%	13.0%	69.3%	1.6%	5904
Maicao	6.6%	7.5%	10.4%	75.0%	0.5%	1178
Malambo	5.6%	6.4%	7.8%	78.9%	1.4%	787
Manizales	4.5%	6.1%	6.5%	82.0%	0.9%	2771
Medellín	5.4%	7.3%	7.3%	78.4%	1.6%	17124
Meta	4.7%	6.3%	7.3%	80.5%	1.1%	3790
Montería	5.2%	7.6%	9.5%	76.6%	1.0%	4178
Mosquera	2.6%	3.6%	4.0%	89.1%	0.7%	1158
Nariño	4.3%	5.2%	7.8%	81.6%	1.0%	6043
Neiva	3.7%	4.8%	5.3%	85.4%	0.8%	2950
Norte de Santander	4.7%	5.1%	7.1%	82.3%	0.7%	5090
Palmira	3.0%	4.8%	5.0%	86.1%	1.0%	2329
Pasto	3.1%	4.3%	4.4%	87.5%	0.7%	3212
Pereira	3.8%	4.9%	5.4%	85.3%	0.7%	3749
Piedecuesta	3.6%	4.4%	4.5%	86.5%	1.0%	1186
Pitalito	2.2%	4.2%	6.3%	86.6%	0.7%	1067
Popayán	2.9%	4.2%	5.7%	86.2%	1.1%	2459
Putumayo	3.5%	5.0%	8.0%	82.1%	1.4%	2701
Quibdó	8.1%	10.9%	13.4%	64.0%	3.7%	1086
Quindío	4.8%	8.6%	8.9%	77.0%	0.8%	2039
Riohacha	6.8%	7.8%	7.0%	77.0%	1.4%	1341
Rionegro	5.0%	4.2%	5.2%	85.0%	0.6%	1086
Risaralda	4.8%	6.0%	8.2%	80.2%	0.7%	1936
Sabaneta	3.0%	4.4%	6.3%	85.3%	1.0%	496
Sahagún	5.1%	8.5%	9.5%	75.8%	1.0%	1079
San Andrés	6.0%	11.0%	12.1%	69.4%	1.5%	529
Santa Marta	6.5%	8.3%	9.3%	74.2%	1.7%	4355
Santander	3.6%	5.1%	6.4%	84.2%	0.7%	6431

Continúa en la siguiente página

ETC/País	A	B	C	D	Omisión y multimarca	N° estudiantes
Sincelejo	6.5%	8.5%	8.0%	76.3%	0.6%	2696
Soacha	4.1%	5.1%	5.3%	84.5%	1.0%	4802
Sogamoso	2.1%	2.5%	3.3%	91.7%	0.3%	1267
Soledad	4.7%	7.3%	7.0%	79.7%	1.3%	4098
Sucre	6.5%	7.7%	10.9%	73.8%	1.1%	5462
Tolima	5.4%	6.0%	8.3%	79.2%	1.0%	6958
Tuluá	4.0%	5.5%	6.4%	83.1%	0.9%	1832
Tumaco	7.4%	10.3%	13.2%	66.9%	2.1%	1334
Tunja	2.5%	4.3%	4.5%	88.3%	0.5%	1740
Turbo	6.6%	9.4%	12.2%	70.6%	1.2%	1254
Uribe	5.9%	8.5%	13.4%	72.2%	0.0%	306
Valle del Cauca	4.6%	6.6%	8.3%	79.7%	0.9%	6252
Valledupar	4.4%	7.0%	8.1%	79.7%	0.8%	4092
Vichada	5.2%	6.2%	7.7%	78.5%	2.5%	404
Villavicencio	3.8%	6.4%	5.9%	83.0%	0.9%	4110
Yopal	2.8%	4.6%	4.9%	87.2%	0.5%	1395
Yumbo	5.9%	5.8%	5.8%	80.9%	1.6%	894
Zipaquirá	2.4%	3.0%	3.9%	90.0%	0.6%	1155
Colombia	4.6%	6.2%	7.3%	80.8%	1.1%	381884

*Es posible que los porcentajes mostrados no sumen exactamente 100 debido a aproximaciones decimales.

• **Pregunta 40.**

En la figura se muestra un prisma hexagonal.

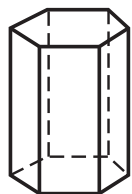

Figura

NO es correcto afirmar que el prisma tiene

- A. 6 caras rectangulares.
- B. 10 vértices.
- C. 2 caras hexagonales.
- D. 18 aristas.

• **Estructura**

Competencia	Comunicación
Componente	Espacial - métrico
Afirmación	Representar y describir propiedades de objetos tridimensionales desde diferentes posiciones y vistas.
Nivel de desempeño	Avanzado
Respuesta Correcta	B

• Resultados a nivel nacional y de Entidad Territorial Certificada (ETC)

ETC/País	A	B	C	D	Omisión y multimarca	N° estudiantes
Amazonas	26.5%	31.1%	16.3%	21.4%	4.8%	627
Antioquia	22.5%	37.1%	14.5%	24.0%	1.9%	19242
Apartadó	23.5%	33.9%	18.2%	22.6%	1.7%	1088
Arauca	20.2%	37.9%	14.4%	26.7%	0.8%	1581
Armenia	20.3%	40.2%	13.5%	24.9%	1.1%	2587
Atlántico	28.5%	32.0%	17.3%	20.4%	1.7%	4931
Barrancabermeja	21.0%	42.0%	13.6%	22.3%	1.2%	1845
Barranquilla	20.5%	43.0%	14.3%	20.7%	1.5%	10592
Bello	19.6%	43.2%	13.8%	21.9%	1.6%	3031
Bogotá, D.C.	16.0%	48.6%	10.8%	23.5%	1.1%	62071
Bolívar	29.5%	30.3%	19.2%	18.8%	2.2%	7541
Boyacá	19.2%	42.8%	11.8%	25.4%	0.8%	7838
Bucaramanga	14.5%	51.0%	10.5%	22.8%	1.2%	4497
Buenaventura	29.0%	29.1%	18.7%	21.0%	2.3%	2787
Buga	20.5%	43.8%	12.0%	23.0%	0.7%	917
Caldas	23.3%	35.7%	16.2%	23.8%	0.9%	4429
Cali	19.0%	42.8%	13.7%	22.9%	1.5%	16580
Caquetá	25.8%	33.9%	17.9%	21.7%	0.8%	1657
Cartagena	23.0%	36.7%	16.8%	22.0%	1.5%	9659
Cartago	20.2%	44.5%	11.8%	22.0%	1.5%	1017
Casanare	20.9%	39.3%	14.8%	24.3%	0.7%	2177
Cauca	28.5%	34.0%	16.2%	19.7%	1.6%	8222
Cesar	25.6%	35.6%	16.7%	21.4%	0.8%	5409
Chocó	32.5%	28.1%	18.7%	18.6%	2.1%	2051
Chía	12.1%	55.2%	8.1%	23.7%	0.9%	1416
Ciénaga	32.3%	26.5%	19.7%	19.1%	2.5%	1060
Cundinamarca	18.2%	44.4%	11.6%	24.8%	1.0%	13372
Córdoba	26.9%	32.1%	17.8%	21.5%	1.6%	8943
Cúcuta	18.7%	44.6%	12.1%	23.4%	1.2%	5733
Dosquebradas	18.0%	46.3%	12.7%	22.5%	0.5%	1319
Duitama	11.8%	55.4%	8.8%	24.1%	0.0%	1251
Envigado	12.6%	56.0%	9.6%	21.2%	0.6%	1633
Facatativá	17.1%	46.8%	10.2%	25.2%	0.7%	1113
Florencia	21.0%	38.8%	14.6%	24.2%	1.4%	1383
Floridablanca	12.2%	52.7%	10.3%	23.9%	0.9%	1982
Fusagasugá	16.2%	47.6%	12.6%	22.5%	1.1%	1119
Girardot	25.5%	37.5%	14.9%	21.1%	1.0%	912

Continúa en la siguiente página



ETC/País	A	B	C	D	Omisión y multimarca	N° estudiantes
Girón	16.2%	43.4%	11.7%	28.0%	0.6%	1109
Guainía	24.0%	36.1%	15.8%	21.3%	2.7%	183
Guaviare	24.3%	37.5%	15.3%	21.4%	1.4%	621
Huila	21.7%	40.5%	12.4%	24.6%	0.8%	5192
Ibagué	18.4%	43.7%	14.1%	22.8%	1.1%	4714
Ipiales	18.0%	43.1%	12.8%	25.4%	0.8%	1066
Itagüí	16.4%	41.4%	13.7%	26.4%	2.1%	1746
Jamundí	23.1%	41.5%	13.0%	20.8%	1.6%	939
La Guajira	29.3%	31.7%	18.0%	19.9%	1.1%	2203
Lorica	30.9%	30.2%	19.3%	17.8%	1.7%	1329
Magangué	27.6%	33.6%	17.6%	19.4%	1.8%	1065
Magdalena	30.8%	29.4%	18.7%	19.0%	2.1%	5904
Maicao	25.8%	34.3%	17.6%	21.2%	1.1%	1178
Malambo	29.0%	38.1%	13.5%	17.9%	1.5%	787
Manizales	18.9%	43.0%	14.4%	22.7%	0.9%	2771
Medellín	18.3%	43.1%	13.5%	23.4%	1.8%	17124
Meta	23.3%	39.7%	13.4%	22.6%	1.1%	3790
Montería	22.5%	38.9%	15.1%	22.1%	1.4%	4178
Mosquera	13.1%	53.3%	9.7%	23.1%	0.8%	1158
Nariño	20.3%	38.7%	14.8%	24.9%	1.3%	6043
Neiva	18.4%	45.4%	11.3%	24.1%	0.9%	2950
Norte de Santander	20.7%	41.8%	13.5%	23.0%	0.9%	5090
Palmira	15.6%	49.2%	11.3%	22.7%	1.2%	2329
Pasto	15.3%	48.1%	10.1%	25.2%	1.2%	3212
Pereira	18.1%	43.9%	12.8%	24.3%	0.9%	3749
Piedecuesta	16.6%	47.0%	12.0%	23.1%	1.3%	1186
Pitalito	18.7%	45.4%	11.0%	23.9%	1.0%	1067
Popayán	19.3%	45.4%	11.6%	22.4%	1.3%	2459
Putumayo	23.1%	38.8%	12.5%	24.1%	1.5%	2701
Quibdó	31.4%	29.0%	17.6%	18.2%	3.8%	1086
Quindío	23.1%	38.7%	15.5%	21.5%	1.2%	2039
Riohacha	22.7%	35.9%	16.9%	23.0%	1.5%	1341
Rionegro	12.7%	49.7%	13.1%	23.8%	0.6%	1086
Risaralda	23.7%	35.5%	14.0%	25.6%	1.2%	1936
Sabaneta	13.3%	54.8%	11.3%	19.4%	1.2%	496
Sahagún	22.2%	38.6%	16.6%	21.5%	1.1%	1079
San Andrés	25.1%	37.4%	15.3%	21.2%	0.9%	529
Santa Marta	24.3%	35.3%	16.2%	22.0%	2.2%	4355
Santander	18.4%	44.6%	12.1%	24.0%	0.8%	6431

Continúa en la siguiente página

ETC/País	A	B	C	D	Omisión y multimarca	N° estudiantes
Sincelejo	22.9%	40.3%	15.0%	20.9%	0.9%	2696
Soacha	20.7%	39.9%	11.7%	26.6%	1.1%	4802
Sogamoso	12.4%	49.7%	10.3%	27.2%	0.4%	1267
Soledad	21.9%	39.4%	14.5%	22.6%	1.7%	4098
Sucre	28.5%	30.7%	19.3%	20.4%	1.2%	5462
Tolima	25.4%	33.8%	16.1%	23.5%	1.2%	6958
Tuluá	20.4%	41.2%	14.5%	22.6%	1.3%	1832
Tumaco	32.8%	28.4%	21.2%	14.2%	3.4%	1334
Tunja	14.4%	51.9%	9.0%	24.3%	0.5%	1740
Turbo	28.6%	28.9%	19.9%	20.9%	1.7%	1254
Uribe	28.1%	33.3%	17.6%	20.3%	0.7%	306
Valle del Cauca	23.6%	36.5%	14.8%	23.7%	1.4%	6252
Valledupar	23.0%	37.4%	14.7%	23.7%	1.2%	4092
Vichada	28.0%	36.9%	14.6%	18.3%	2.2%	404
Villavicencio	18.0%	45.7%	12.9%	22.6%	0.9%	4110
Yopal	18.1%	46.2%	11.8%	23.3%	0.6%	1395
Yumbo	17.4%	44.1%	13.2%	23.6%	1.7%	894
Zipaquirá	14.5%	52.4%	8.8%	23.5%	0.8%	1155
Colombia	20.8%	41.2%	13.8%	22.9%	1.3%	381884

*Es posible que los porcentajes mostrados no sumen exactamente 100 debido a aproximaciones decimales.

• **Pregunta 41.**

Una pelota se deja caer desde una altura de 1.080 cm. En la gráfica se muestran las alturas que alcanza la pelota en cada rebote.

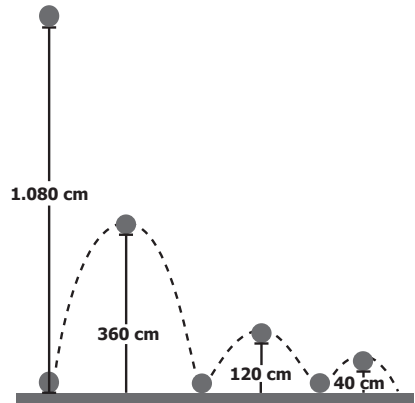

Gráfica

La altura de cada rebote es

- A. un noveno de la altura alcanzada en el rebote anterior.
- B. un cuarto de la altura alcanzada en el rebote anterior.
- C. un tercio de la altura alcanzada en el rebote anterior.
- D. un medio de la altura alcanzada en el rebote anterior.

• **Estructura**

Competencia	Comunicación
Componente	Numérico - variacional
Afirmación	Reconocer el lenguaje algebraico como forma de representar procesos inductivos.
Nivel de desempeño	Avanzado
Respuesta Correcta	C

• Resultados a nivel nacional y de Entidad Territorial Certificada (ETC)

ETC/País	A	B	C	D	Omisión y multimarca	N° estudiantes
Amazonas	23.6%	21.9%	26.0%	25.2%	3.3%	627
Antioquia	16.4%	20.4%	41.4%	19.7%	2.2%	19242
Apartadó	20.2%	22.8%	34.2%	21.4%	1.4%	1088
Arauca	14.8%	21.6%	40.2%	21.9%	1.5%	1581
Armenia	14.0%	20.0%	44.0%	20.5%	1.5%	2587
Atlántico	19.3%	21.5%	35.6%	21.5%	2.1%	4931
Barrancabermeja	16.5%	20.4%	43.5%	18.1%	1.5%	1845
Barranquilla	15.8%	21.0%	42.2%	19.2%	1.8%	10592
Bello	15.5%	20.5%	42.9%	19.2%	1.9%	3031
Bogotá, D.C.	12.2%	19.1%	49.6%	17.7%	1.4%	62071
Bolívar	21.6%	22.1%	32.7%	21.0%	2.6%	7541
Boyacá	13.7%	19.0%	47.3%	18.9%	1.1%	7838
Bucaramanga	12.1%	16.9%	52.3%	17.1%	1.6%	4497
Buenaventura	21.2%	23.4%	32.4%	20.4%	2.7%	2787
Buga	13.5%	20.1%	44.8%	20.3%	1.3%	917
Caldas	17.1%	20.5%	41.2%	20.3%	0.9%	4429
Cali	14.8%	20.2%	43.8%	19.4%	1.7%	16580
Caquetá	20.0%	21.2%	38.6%	18.8%	1.4%	1657
Cartagena	18.7%	21.0%	39.5%	19.4%	1.4%	9659
Cartago	14.1%	22.6%	41.4%	19.8%	2.2%	1017
Casanare	14.7%	21.4%	42.8%	19.9%	1.2%	2177
Cauca	20.3%	21.2%	36.4%	20.3%	1.9%	8222
Cesar	18.7%	22.1%	37.0%	21.4%	0.8%	5409
Chocó	23.9%	21.4%	31.3%	21.5%	2.0%	2051
Chía	9.3%	17.9%	52.5%	19.4%	0.9%	1416
Ciénaga	23.3%	21.1%	32.5%	21.8%	1.3%	1060
Cundinamarca	13.3%	19.1%	47.9%	18.5%	1.3%	13372
Córdoba	20.9%	22.5%	34.2%	20.9%	1.6%	8943
Cúcuta	15.5%	19.4%	46.1%	18.0%	1.0%	5733
Dosquebradas	12.9%	23.0%	46.2%	17.1%	0.8%	1319
Duitama	9.3%	20.1%	54.5%	15.7%	0.5%	1251
Envigado	10.6%	15.3%	58.4%	14.8%	0.9%	1633
Facatativá	11.1%	18.9%	52.6%	17.1%	0.4%	1113
Florencia	16.5%	19.1%	42.8%	20.0%	1.6%	1383
Floridablanca	11.4%	17.1%	53.5%	16.8%	1.3%	1982
Fusagasugá	13.8%	19.4%	45.9%	19.8%	1.1%	1119
Girardot	16.3%	23.0%	37.7%	21.6%	1.3%	912

Continúa en la siguiente página



ETC/País	A	B	C	D	Omisión y multimarca	N° estudiantes
Girón	14.4%	20.6%	47.2%	17.3%	0.4%	1109
Guainía	19.7%	17.5%	35.5%	24.6%	2.7%	183
Guaviare	18.7%	18.7%	38.5%	22.5%	1.6%	621
Huila	16.4%	22.3%	40.5%	19.8%	1.0%	5192
Ibagué	14.1%	19.2%	45.6%	20.0%	1.1%	4714
Ipiales	15.5%	21.2%	43.1%	19.6%	0.7%	1066
Itagüí	16.2%	22.5%	40.4%	18.7%	2.3%	1746
Jamundí	16.7%	20.4%	41.9%	19.7%	1.3%	939
La Guajira	20.9%	22.5%	34.7%	21.0%	1.0%	2203
Lorica	21.3%	22.3%	32.8%	22.3%	1.4%	1329
Magangué	19.4%	22.6%	34.9%	20.9%	2.1%	1065
Magdalena	22.6%	22.2%	31.8%	21.2%	2.2%	5904
Maicao	19.8%	23.5%	33.5%	22.2%	1.0%	1178
Malambo	18.7%	16.9%	44.9%	17.8%	1.8%	787
Manizales	13.8%	20.7%	45.7%	18.8%	1.1%	2771
Medellín	15.3%	20.0%	44.1%	18.7%	1.9%	17124
Meta	15.3%	21.0%	40.8%	21.5%	1.5%	3790
Montería	18.0%	22.2%	37.8%	20.5%	1.5%	4178
Mosquera	10.6%	18.0%	53.1%	16.8%	1.5%	1158
Nariño	15.6%	19.9%	42.8%	20.4%	1.3%	6043
Neiva	14.9%	20.9%	45.8%	16.7%	1.6%	2950
Norte de Santander	15.1%	20.7%	44.3%	18.5%	1.3%	5090
Palmira	13.4%	19.6%	46.8%	18.4%	1.8%	2329
Pasto	12.3%	18.9%	48.1%	19.4%	1.2%	3212
Pereira	13.3%	20.2%	45.3%	20.1%	1.2%	3749
Piedecuesta	13.7%	18.5%	48.0%	18.5%	1.3%	1186
Pitalito	14.3%	21.3%	46.7%	16.9%	0.8%	1067
Popayán	13.4%	19.1%	48.1%	18.0%	1.3%	2459
Putumayo	15.2%	21.4%	41.2%	20.6%	1.5%	2701
Quibdó	21.0%	22.1%	31.9%	21.5%	3.6%	1086
Quindío	17.2%	21.9%	38.1%	21.2%	1.6%	2039
Riohacha	22.0%	18.6%	38.7%	18.8%	1.9%	1341
Rionegro	12.8%	17.2%	50.6%	18.4%	0.9%	1086
Risaralda	16.3%	20.0%	42.1%	20.1%	1.4%	1936
Sabaneta	14.1%	21.2%	48.4%	14.7%	1.6%	496
Sahagún	19.7%	20.6%	36.9%	21.4%	1.4%	1079
San Andrés	16.3%	23.4%	37.2%	22.1%	0.9%	529
Santa Marta	17.7%	21.8%	37.0%	21.1%	2.4%	4355
Santander	13.7%	20.2%	46.4%	18.7%	1.1%	6431

Continúa en la siguiente página

ETC/País	A	B	C	D	Omisión y multimarca	Nº estudiantes
Sincelejo	18.9%	19.6%	39.7%	20.8%	1.1%	2696
Soacha	15.4%	20.4%	42.8%	20.1%	1.4%	4802
Sogamoso	11.0%	17.0%	54.0%	17.5%	0.5%	1267
Soledad	18.9%	20.4%	40.0%	18.8%	1.9%	4098
Sucre	20.9%	22.4%	33.7%	21.7%	1.3%	5462
Tolima	17.7%	20.9%	38.7%	21.3%	1.4%	6958
Tuluá	14.7%	21.0%	43.6%	19.3%	1.4%	1832
Tumaco	23.1%	23.8%	29.0%	21.2%	2.8%	1334
Tunja	10.2%	18.9%	52.6%	17.0%	1.3%	1740
Turbo	20.7%	25.7%	29.4%	22.6%	1.5%	1254
Uribe	25.5%	22.2%	24.5%	26.1%	1.6%	306
Valle del Cauca	16.7%	21.8%	39.3%	20.9%	1.3%	6252
Valledupar	19.3%	21.6%	37.8%	20.1%	1.3%	4092
Vichada	22.3%	20.0%	29.7%	24.5%	3.5%	404
Villavicencio	12.8%	19.8%	48.2%	17.9%	1.3%	4110
Yopal	13.0%	21.9%	47.0%	17.3%	0.7%	1395
Yumbo	16.8%	22.1%	40.6%	18.1%	2.3%	894
Zipaquirá	13.2%	17.0%	49.2%	19.7%	1.0%	1155
Colombia	15.8%	20.4%	43.0%	19.3%	1.5%	381884

*Es posible que los porcentajes mostrados no sumen exactamente 100 debido a aproximaciones decimales.

